



DRIVEN TOOLING

For

BARUFFALDI Turrets



10139 BERGIN RD.

HOWELL, MI 48843

PHONE : 877-91-TOOLS (810-632-4446)

FAX: 877-92-TOOLS (810-632-4467)

EMAIL: info@mdtooling.com

WEBSITE: www.mdtooling.com

Live Tooling



M. T. Marchetti, a major live tool manufacturer in northern Italy, is a leader in live tool technology. The formula is simple. Use only the best angular contact high-speed bearings available. Add to this an exacting tolerances for all ground shafts, gears and bearing pocket features. Next, develop a sealed system that **will not** allow any contamination from chips or coolant.

Top this all off with a superior design and you end up with a live tool that is more rigid, faster and will last longer. **We back this up with a 2-Year factory warranty.**

Our Live Tool Warranty

Our tooling will give years of service in the most demanding applications. The superior design and rugged construction has proven this over the last 12 years. The reliability of our tools allows us to provide a 2-year factory warranty, for non-wear components.

MD Tooling will repair any defective tool holders for a period of 2 years from the date of purchase.

Product Range

We have the largest range of live tooling available for most major machine tool manufactures.

Our available products include an extensive line of standard live tooling as well as specialty tool holders such as 0-180 adjustable angle tool holders, gear hobbors, and even worm gear generators. Our product range includes geared up holders to 60,000 RPM and are engineered for 1,000 PSI coolant through.

We are an industry leader in providing complete tooling solutions with hundreds of static tool options as well.

Technical Support

Here at MD Tooling we have a full technical support department with over 35 years of CNC experience.

Our highly qualified staff can help with part processing, tooling up a job from a blue print and even assist with part programming. Applications Engineers are always available by phone to answer any questions you may have about our tooling or any other CNC related issue.

Stock and Replenishment

MD Tooling maintains an extensive inventory of tooling in our warehouse in Michigan. Our current "fill" rate on orders is 93% from our stock in Michigan for same day shipping.

Should you require a non-stock item, our manufacturer, M.T. Marchetti also maintains a large inventory in Italy. Tooling can be obtained in as little as 3-5 business days.

Shipping

MD Tooling realizes that when you need tooling, often you can't wait until the next day. We process orders and ship from available stock right up until 4PM EST to make certain we get your tooling solutions to you as quickly as possible.

We regularly ship throughout the day via UPS, FedEx or any other carrier that a customer requests.



10139 Bergin Road
Howell, MI 48843
Phone: (810) 632-4446
Fax: (810) 632-4467
Email: info@mdtooling.com
Web: www.mdtooling.com

- Fast, Friendly, Reliable Service!
- Quality tooling at highly competitive pricing.
- 2-Year Warranty on all live tools.
- Extensive inventory. We currently ship over 93% of all orders same day.
- In-house repair services available.
- If a warranty tool needs to be returned for inspection, service or repair, loaner tools are available to keep your machine tool production up and running.
- More specialty tool holders than any other manufacturer.
- Custom tool holders available.
- All available tooling may not be shown in this catalog. If you can't find the holder you're looking for, please contact our office for assistance.



Table of Contents

Categorized Listing

VDI30	1
DRIVEN	1
RADIAL DRIVEN TOOL VDI30 - RIGHT HAND	1
RADIAL DRIVEN TOOL VDI30 - LEFT HAND	1
RADIAL REAR-SET DRIVEN TOOL VDI30 H=75mm - RIGHT HAND	2
RADIAL REAR-SET DRIVEN TOOL VDI30 H=75mm - LEFT HAND	3
RADIAL REAR-SET DRIVEN TOOL VDI30 H=85mm - RIGHT HAND	4
RADIAL REAR-SET DRIVEN TOOL VDI30 H=85mm - LEFT HAND	5
QUICK CHANGE RADIAL MTSK-32 REAR SET DRIVEN TOOL VDI30 H=75mm	6
QUICK CHANGE RADIAL MTSK-32 REAR SET DRIVEN TOOL VDI30 H=75mm	6
QUICK CHANGE RADIAL MTSK-32 REAR SET DRIVEN TOOL VDI30 H=85mm	7
QUICK CHANGE RADIAL MTSK-32 REAR SET DRIVEN TOOL VDI30 H=85mm	7
AXIAL DRIVEN TOOL VDI30	8
VDI40	9
DRIVEN	9
RADIAL DRIVEN TOOL VDI40 H=100mm - RIGHT HAND	9
RADIAL DRIVEN TOOL VDI40 H=100mm - LEFT HAND	9
RADIAL REAR-SET DRIVEN TOOL VDI40 H=85mm - RIGHT HAND	10
RADIAL REAR-SET DRIVEN TOOL VDI40 H=85mm - LEFT HAND	10
RADIAL GEARED-DOWN 2:1 REAR SET DRIVEN TOOL H=85mm VDI40 - RIGHT	11
AXIAL DRIVEN TOOL VDI40	12
QUICK CHANGE AXIAL MTSK-40 DRIVEN TOOL VDI40	12
AXIAL DRIVEN TOOL RE-DIRECTED BY 42mm VDI40 - RIGHT HAND	13
AXIAL GEARED-DOWN 2:1 RE-DIRECTED BY 42mm VDI40 - RIGHT	13
AXIAL GEARED-UP 1:2 DRIVEN TOOL RE-DIRECTED BY 42mm VDI40	14
(0-180) ADJUSTABLE ANGLE DRIVEN TOOL VDI40 - RIGHT HAND	15
(0-180) ADJUSTABLE ANGLE DRIVEN TOOL WITH DIGITAL DISPLAY VDI40	16
DRIVEN GEAR HOBBER VDI40	16
BROACHING/SLOTTING DRIVEN TOOL 25mm STROKE VDI40	17
BROACHING/SLOTTING DRIVEN TOOL 50mm STROKE VDI40	17
VDI50	18
DRIVEN	18
RADIAL DRIVEN TOOL VDI50	18
RADIAL DRIVEN TOOL FOR INTERNAL TOOLING VDI50	18
AXIAL DRIVEN TOOL VDI50	19
AXIAL DRIVEN TOOL RE-DIRECTED BY 60mm VDI50	19
DRIVEN GEAR HOBBER VDI50 - RIGHT HAND	20
ACCESSORIES	21
DRIVEN	21
MTSK-32 ER ADAPTORS	21
MTSK-32 MILL ADAPTORS	22
MTSK-40 ER ADAPTORS	23
MTSK-40 MILL ADAPTORS	24
TOOL DISASSEMBLING EQUIPMENT FOR MTSK	25

VDI30

DRIVEN

RADIAL DRIVEN TOOL VDI30 - RIGHT HAND

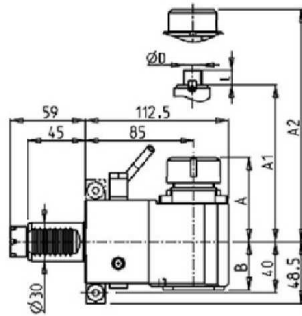
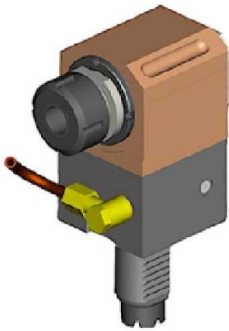

right version
version rechts

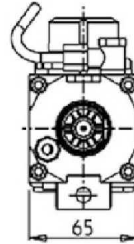

left version
version links

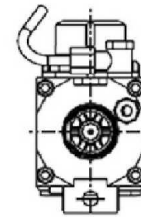

PartNumber	Description	Spindle	I	RPM	Cool Thru	Ext Cool	D	L	A	A1	A2	B
BAR0060125	Radial Driven ER25	ER25	1:1	6000		X			66.2			38
BAR0060225	Radial Driven ER25 Cool Thru*	ER25	1:1	6000	X	X			66.2			48
BAR0060416	Radial Milling Head 16x17	16x17	1:1	6000		X	16	17		45		38
BAR0060422	Radial Milling Head 22x19	22x19	1:1	6000		X	22	19		47		38
BAR0060316	Radial Driven Weldon 16	Weldon 16	1:1	6000		X					54.5	38

* Coolant Thru tools are designed for 1000 psi.
They require 5 Micron Filtration and **CANNOT** be run dry.

RADIAL DRIVEN TOOL VDI30 - LEFT HAND

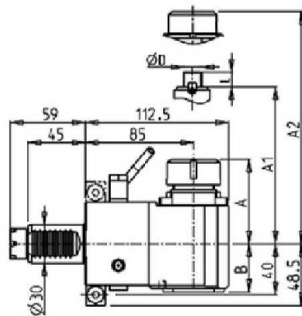
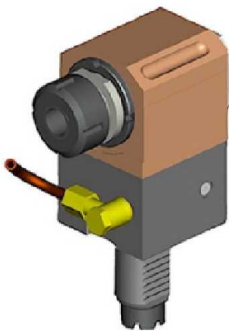

right version
version rechts

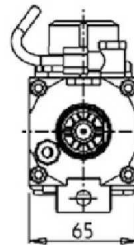

left version
version links

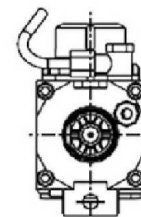

PartNumber	Description	Spindle	I	RPM	Cool Thru	Ext Cool	D	L	A	A1	A2	B
BAR0061125	Radial Driven ER25	ER25	1:1	6000		X			66.2			38
BAR0061225	Radial Driven ER25 Cool Thru*	ER25	1:1	6000	X	X			66.2			48
BAR0061416	Radial Milling Head 16x17	16x17	1:1	6000		X	16	17		45		38
BAR0061422	Radial Milling Head 22x19	22x19	1:1	6000		X	22	19		47		38
BAR0061316	Radial Driven Weldon 16	Weldon 16	1:1	6000		X					54.5	38

* Coolant Thru tools are designed for 1000 psi.
They require 5 Micron Filtration and **CANNOT** be run dry.

VDI30

DRIVEN

RADIAL REAR-SET DRIVEN TOOL VDI30 H=75mm - RIGHT HAND

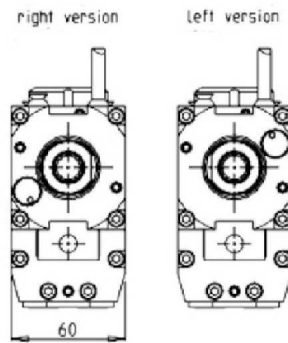
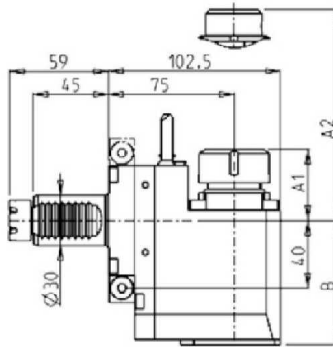

PartNumber	Description	Spindle	I	RPM	Cool Thru	Ext Cool	A1	A2	B
BAR0080120	Radial Rear-Set ER20	ER20	1:1	6000		X	41.16		73.5
BAR0080220	Radial Rear-Set ER20 Cool Thru*	ER20	1:1	6000	X	X	41.16		83.5
BAR0080320	Radial Rear-Set ERA20	ERA20	1:1	6000		X	24.5		73.5
BAR0080420	Radial Rear-Set ERA20 Cool Thru*	ERA20	1:1	6000	X	X	24.5		83.5
BAR0080125	Radial Rear-Set ER25	ER25	1:1	6000		X	42.16		73.5
BAR0080225	Radial Rear-Set ER25 Cool Thru*	ER25	1:1	6000	X	X	42.16		83.5
BAR0080325	Radial Rear-Set ERA25	ERA25	1:1	6000		X	28.5		73.5
BAR0080425	Radial Rear-Set ERA25 Cool Thru*	ERA25	1:1	6000	X	X	28.5		83.5
BAR0080516	Radial Rear-Set Weldon16	Weldon 16	1:1	6000		X		27.5	73.5

* Coolant Thru tools are designed for 1000 psi.
They require 5 Micron Filtration and **CANNOT** be run dry.

VDI30

DRIVEN

RADIAL REAR-SET DRIVEN TOOL VDI30 H=75mm - LEFT HAND

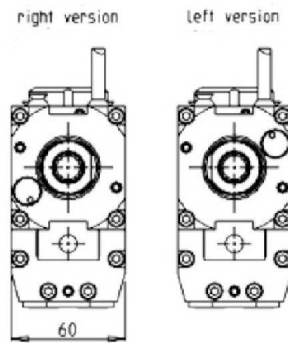
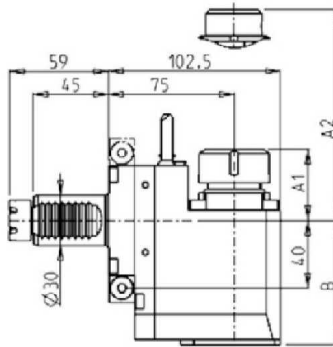

PartNumber	Description	Spindle	I	RPM	Cool Thru	Ext Cool	A1	A2	B
BAR0081120	Radial Rear-Set ER20	ER20	1:1	6000		X	41.16		73.5
BAR0081220	Radial Rear-Set ER20 Cool Thru*	ER20	1:1	6000	X	X	41.16		83.5
BAR0081320	Radial Rear-Set ERA20	ERA20	1:1	6000		X	24.5		73.5
BAR0081420	Radial Rear-Set ERA20 Cool Thru*	ERA20	1:1	6000	X	X	24.5		83.5
BAR0081125	Radial Rear-Set ER25	ER25	1:1	6000		X	42.16		73.5
BAR0081225	Radial Rear-Set ER25 Cool Thru*	ER25	1:1	6000	X	X	42.16		83.5
BAR0081325	Radial Rear-Set ERA25	ERA25	1:1	6000		X	28.5		73.5
BAR0081425	Radial Rear-Set ERA25 Cool Thru*	ERA25	1:1	6000	X	X	28.5		83.5
BAR0081516	Radial Rear-Set Weldon16	Weldon 16	1:1	6000		X		27.5	73.5

* Coolant Thru tools are designed for 1000 psi.
They require 5 Micron Filtration and **CANNOT** be run dry.

VDI30

DRIVEN

RADIAL REAR-SET DRIVEN TOOL VDI30 H=85mm - RIGHT HAND

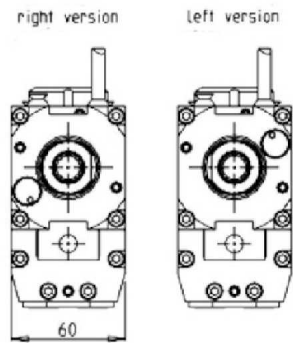
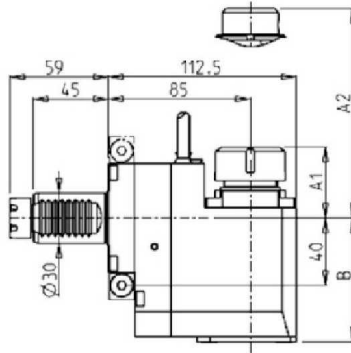

PartNumber	Description	Spindle	I	RPM	Cool Thru	Ext Cool	A1	A2	B
BAR0070120	Radial Rear-Set ER20	ER20	1:1	6000		X	41.16		73.5
BAR0070220	Radial Rear-Set ER20 Cool Thru*	ER20	1:1	6000	X	X	41.16		83.5
BAR0070320	Radial Rear-Set ERA20	ERA20	1:1	6000		X	24.5		73.5
BAR0070420	Radial Rear-Set ERA20 Cool Thru*	ERA20	1:1	6000	X	X	24.5		83.5
BAR0070125	Radial Rear-Set ER25	ER25	1:1	6000		X	42.16		73.5
BAR0070225	Radial Rear-Set ER25 Cool Thru*	ER25	1:1	6000	X	X	42.16		83.5
BAR0070325	Radial Rear-Set ERA25	ERA25	1:1	6000		X	28.5		73.5
BAR0070425	Radial Rear-Set ERA25 Cool Thru*	ERA25	1:1	6000	X	X	28.5		83.5
BAR0070516	Radial Rear-Set Weldon16	Weldon 16	1:1	6000		X		27.5	73.5

* Coolant Thru tools are designed for 1000 psi.
They require 5 Micron Filtration and **CANNOT** be run dry.

VDI30

DRIVEN

RADIAL REAR-SET DRIVEN TOOL VDI30 H=85mm - LEFT HAND

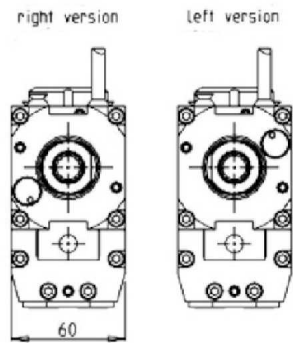
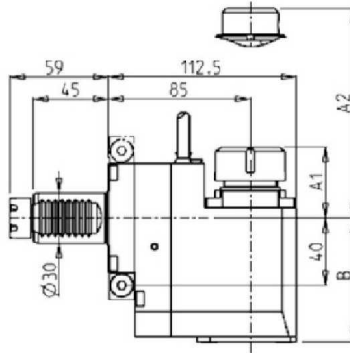

PartNumber	Description	Spindle	I	RPM	Cool Thru	Ext Cool	A1	A2	B
BAR0071120	Radial Rear-Set ER20	ER20	1:1	6000		X	41.16	73.5	
BAR0071220	Radial Rear-Set ER20 Cool Thru*	ER20	1:1	6000	X	X	41.16	83.5	
BAR0071320	Radial Rear-Set ERA20	ERA20	1:1	6000		X	24.5	73.5	
BAR0071420	Radial Rear-Set ERA20 Cool Thru*	ERA20	1:1	6000	X	X	24.5	83.5	
BAR0071125	Radial Rear-Set ER25	ER25	1:1	6000		X	42.16	73.5	
BAR0071225	Radial Rear-Set ER25 Cool Thru*	ER25	1:1	6000	X	X	42.16	83.5	
BAR0071325	Radial Rear-Set ERA25	ERA25	1:1	6000		X	28.5	73.5	
BAR0071425	Radial Rear-Set ERA25 Cool Thru*	ERA25	1:1	6000	X	X	28.5	83.5	
BAR0071516	Radial Rear-Set Weldon16	Weldon 16	1:1	6000		X		27.5	73.5

* Coolant Thru tools are designed for 1000 psi.
They require 5 Micron Filtration and **CANNOT** be run dry.

VDI30

DRIVEN

QUICK CHANGE RADIAL MTSK-32 REAR SET DRIVEN TOOL VDI30 H=75mm - RIGHT HAND

See Accessories for MTSK Clamping Units

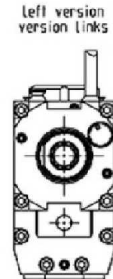
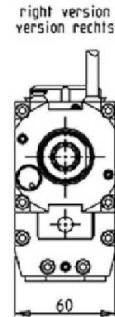
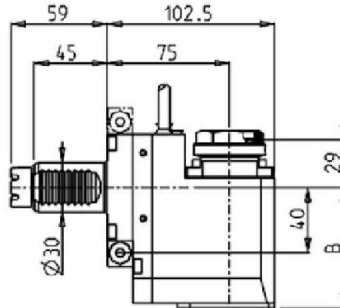

PartNumber	Description	Spindle	I	RPM	Cool Thru	Ext Cool	B
BAR0170132	Radial MTSK-32	MTSK-32	1:1	6000		X	73.5
BAR0170232	Radial MTSK-32 Cool Thru*	MTSK-32	1:1	6000	X	X	83.5

* Coolant Thru tools are designed for 1000 psi.
They require 5 Micron Filtration and **CANNOT** be run dry.

QUICK CHANGE RADIAL MTSK-32 REAR SET DRIVEN TOOL VDI30 H=75mm - LEFT HAND

See Accessories for MTSK Clamping Units

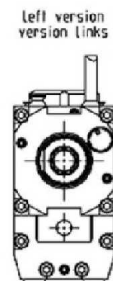
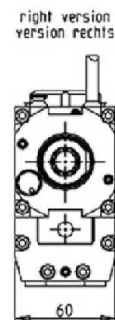
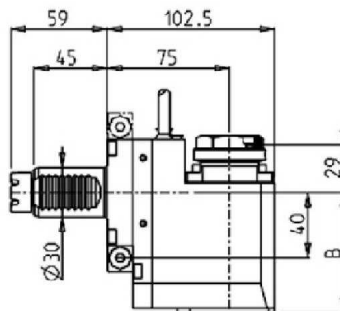

PartNumber	Description	Spindle	I	RPM	Cool Thru	Ext Cool	B
BAR0171132	Radial MTSK-32	MTSK-32	1:1	6000		X	73.5
BAR0171232	Radial MTSK-32 Cool Thru*	MTSK-32	1:1	6000	X	X	83.5

* Coolant Thru tools are designed for 1000 psi.
They require 5 Micron Filtration and **CANNOT** be run dry.

VDI30

DRIVEN

QUICK CHANGE RADIAL MTSK-32 REAR SET DRIVEN TOOL VDI30 H=85mm - RIGHT HAND

See Accessories for MTSK Clamping Units

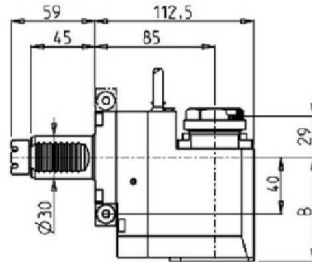

right version
version rechts

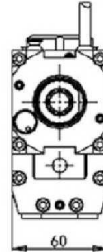

left version
version links

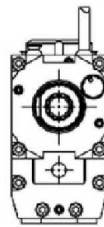

PartNumber	Description	Spindle	I	RPM	Cool Thru	Ext Cool	B
BAR0160132	Radial MTSK-32	MTSK-32	1:1	6000		X	73.5
BAR0160232	Radial MTSK-32 Cool Thru*	MTSK-32	1:1	6000	X	X	83.5

* Coolant Thru tools are designed for 1000 psi.
They require 5 Micron Filtration and **CANNOT** be run dry.

QUICK CHANGE RADIAL MTSK-32 REAR SET DRIVEN TOOL VDI30 H=85mm - LEFT HAND

See Accessories for MTSK Clamping Units

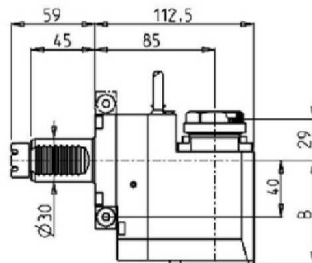

right version
version rechts



left version
version links

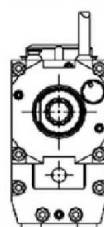

PartNumber	Description	Spindle	I	RPM	Cool Thru	Ext Cool	B
BAR0161132	Radial MTSK-32	MTSK-32	1:1	6000		X	73.5
BAR0161232	Radial MTSK-32 Cool Thru*	MTSK-32	1:1	6000	X	X	83.5

* Coolant Thru tools are designed for 1000 psi.
They require 5 Micron Filtration and **CANNOT** be run dry.

VDI30

DRIVEN

AXIAL DRIVEN TOOL VDI30

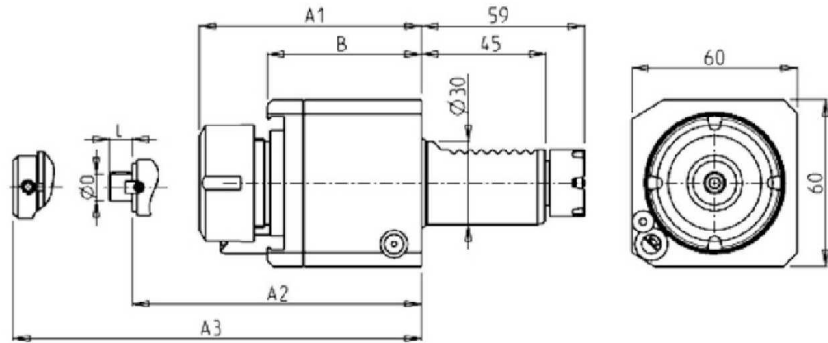
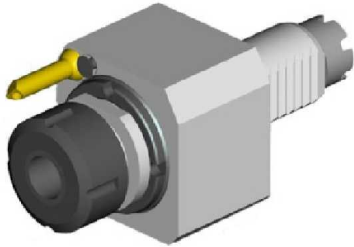

PartNumber	Description	Spindle	I	RPM	Cool Thru	Ext Cool	D	L	A1	A2	A3	B
BAR0040125	Axial Driven ER25	ER25	1:1	6000		X			80.66			56
BAR0041125	Axial Driven ER25 Cool Thru*	ER25	1:1	6000	X	X			94.66			59
BAR0040225	Axial Driven ERA25	ERA25	1:1	6000	X	X			61			56
BAR0041225	Axial Driven ERA25 Cool Thru*	ERA25	1:1	6000	X	X			75			70
BAR0040416	Axial VDI30 Milling Head 16x17	16x17	1:1	6000		X	16	17		59.5		56
BAR0040422	Axial VDI30 Milling Head 22x19	22x19	1:1	6000		X	22	19		61.5		56
BAR0040316	Axial Driven Weldon16	Weldon 16	1:1	6000		X					66.5	56
BAR0041316	Axial Driven Weldon16 Cool Thru*	Weldon 16	1:1	6000	X	X					80	70

*Coolant Thru tools are designed for 400 psi MAX.
They require 5 Micron Filtration and **CANNOT** be run dry.

VDI40

DRIVEN

RADIAL DRIVEN TOOL VDI40 H=100mm - RIGHT HAND

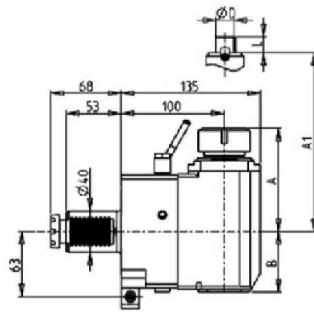

right version
version rechts



left version
version links

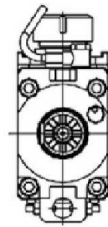

PartNumber	Description	Spindle	I	RPM	Cool Thru	Ext Cool	A	A1	B	D	L
BAR0210132	Radial ER32 VDI40	ER32	1:1	4000		X	99.7		58.5		
BAR0210232	Radial ER32 VDI40 Cool Thru*	ER32	1:1	4000	X	X	99.7		69.5		
BAR0210140	Radial ER40 VDI40	ER40	1:1	4000		X	103.7		58.5		
BAR0210240	Radial ER40 VDI40 Cool Thru*	ER40	1:1	4000	X	X	103.7		69.5		
BAR0210522	Radial Milling Head 22x19 VDI40	22x19	1:1	4000		X		78.5	58.5	22	19
BAR0210527	Radial Milling Head 27x21 VDI40	27x21	1:1	4000		X		78.5	58.5	27	21

* Coolant Thru tools are designed for 1000 psi.
They require 5 Micron Filtration and **CANNOT** be run dry.

RADIAL DRIVEN TOOL VDI40 H=100mm - LEFT HAND

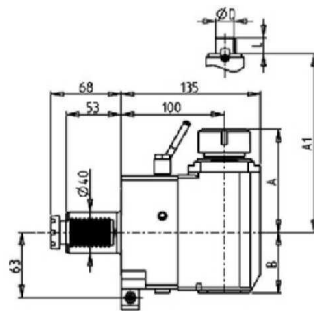

right version
version rechts



left version
version links

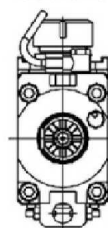

PartNumber	Description	Spindle	I	RPM	Cool Thru	Ext Cool	A	A1	B	D	L
BAR0211132	Radial ER32 VDI40	ER32	1:1	4000		X	99.7		58.5		
BAR0211232	Radial ER32 VDI40 Cool Thru*	ER32	1:1	4000	X	X	99.7		69.5		
BAR0211140	Radial ER40 VDI40	ER40	1:1	4000		X	103.7		58.5		
BAR0211240	Radial ER40 VDI40 Cool Thru*	ER40	1:1	4000	X	X	103.7		69.5		
BAR0211522	Radial Milling Head 22x19 VDI40	22x19	1:1	4000		X		78.5	58.5	22	19
BAR0211527	Radial Milling Head 27x21 VDI40	27x21	1:1	4000		X		78.5	58.5	27	21

* Coolant Thru tools are designed for 1000 psi.
They require 5 Micron Filtration and **CANNOT** be run dry.

VDI40

DRIVEN

RADIAL REAR-SET DRIVEN TOOL VDI40 H=85mm - RIGHT HAND

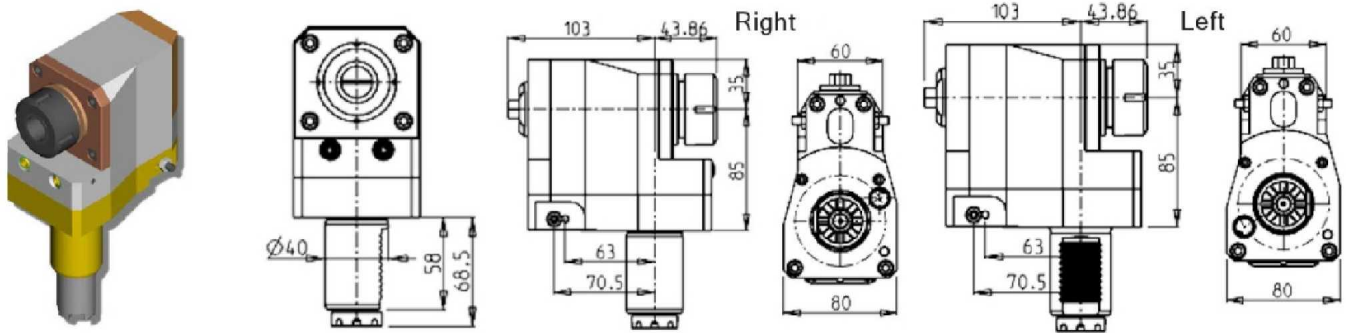

PartNumber	Description	Orientation	Spindle	I	RPM	Ext Cool
161BAR_R32_40C00	Radial Rear-Set ER32	Right Hand	ER32	1:1	4000	X

RADIAL REAR-SET DRIVEN TOOL VDI40 H=85mm - LEFT HAND

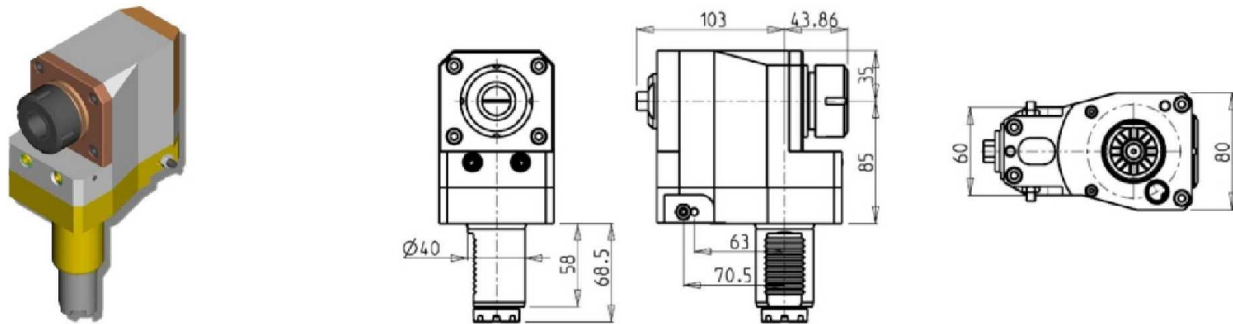

PartNumber	Description	Orientation	Spindle	I	RPM	Ext Cool
161BAR_R32_40C20	Radial Rear-Set ER32	Left Hand	ER32	1:1	4000	X

VDI40

DRIVEN

RADIAL GEARED-DOWN 2:1 REAR SET DRIVEN TOOL H=85mm VDI40 - RIGHT HAND

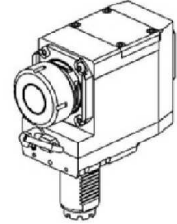
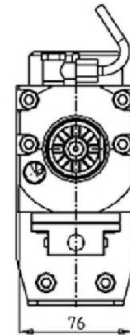
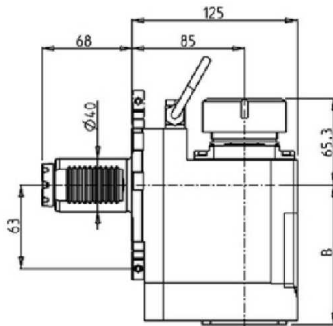

PartNumber	Description	Spindle	I	RPM	Cool Thru	Ext Cool	B
BAR0150140	Radial Geared-Down ER40	ER40	2:1	2000		X	105
BAR0150240	Radial Geared-Down ER40 Cool Thru*	ER40	2:1	2000	X	X	117.5

* Coolant Thru tools are designed for 1000 psi.
They require 5 Micron Filtration and **CANNOT** be run dry.

VDI40

DRIVEN

AXIAL DRIVEN TOOL VDI40

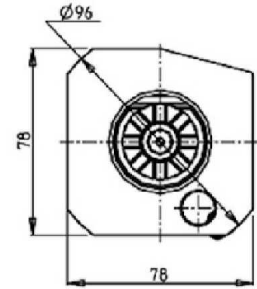
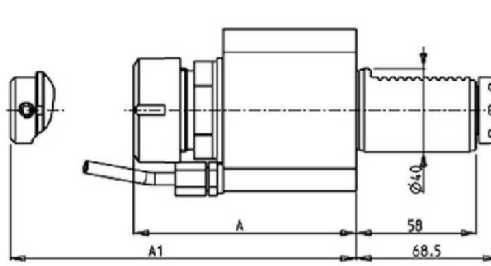
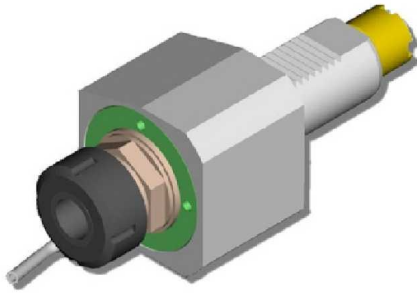

PartNumber	Description	Spindle	I	RPM	Cool Thru	Ext Cool	A	A1
162BAR_A32_40C00	Axial ER32	ER32	1:1	4000		X	107.26	
BAR0240232	Axial ER32 Cool Thru*	ER32	1:1	4000	X	X	112.96	
BAR0130420	Axial Weldon 20	Weldon 20	1:1	4000		X		97.3

* Coolant Thru tools are designed for 1000 psi.
They require 5 Micron Filtration and **CANNOT** be run dry.

QUICK CHANGE AXIAL MTSK-40 DRIVEN TOOL VDI40

See Accessories for MTSK Clamping Units

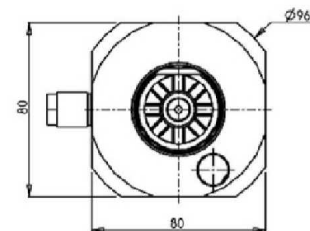
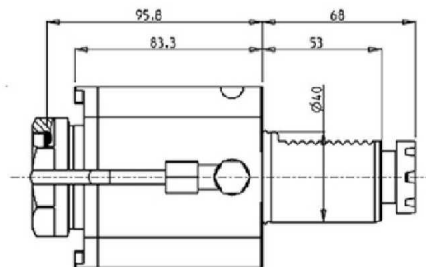

PartNumber	Description	Spindle	I	RPM	Ext Cool
BAR0220140	Axial MTSK-40	MTSK-40	1:1	4000	X

VDI40

DRIVEN

AXIAL DRIVEN TOOL RE-DIRECTED BY 42mm VDI40 - RIGHT HAND

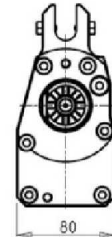
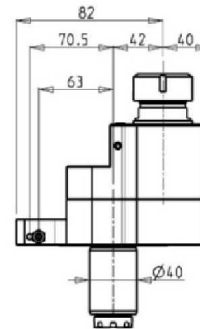
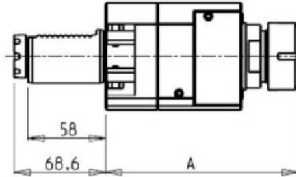

PartNumber	Description	Orientation	Spindle	I	RPM	Cool Thru	Ext Cool	A
165BAR_A32_40C00	Axial Re-Directed ER32	Right Hand	ER32	1:1	4000		X	144.46
165BAR_A32_40C10	Axial Re-Directed ER32 Cool Thru*	Right Hand	ER32	1:1	4000	X		164.96

*Coolant Thru tools are designed for 400 psi MAX.
They require 5 Micron Filtration and **CANNOT** be run dry.

AXIAL GEARED-DOWN 2:1 RE-DIRECTED BY 42mm VDI40 - RIGHT HAND

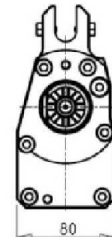
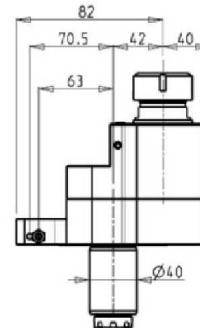
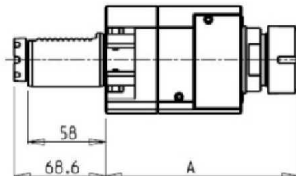
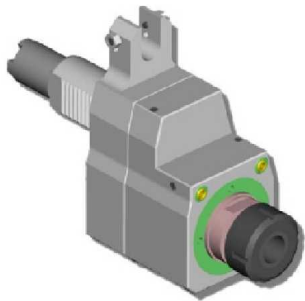

PartNumber	Description	Orientation	Spindle	I	RPM	Cool Thru	Ext Cool	A
165BAR_A32_40C20	Axial Geared-Down ER32	Right Hand	ER32	2:1	2000		X	144.46
165BAR_A32_40C30	Axial Geared-Down ER32 Cool Thru*	Right Hand	ER32	2:1	2000	X		164.96

*Coolant Thru tools are designed for 400 psi MAX.
They require 5 Micron Filtration and **CANNOT** be run dry.

VDI40

DRIVEN

AXIAL GEARED-UP 1:2 DRIVEN TOOL RE-DIRECTED BY 42mm VDI40

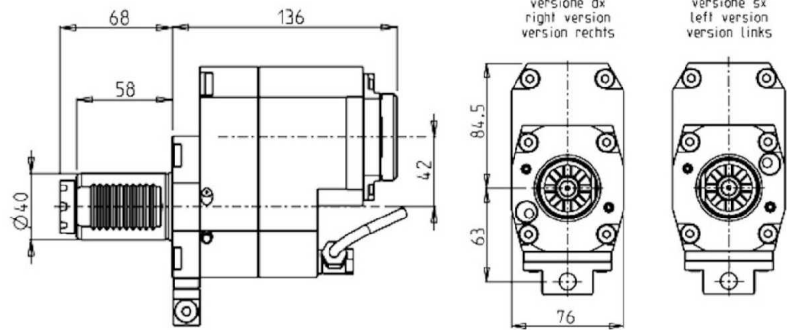
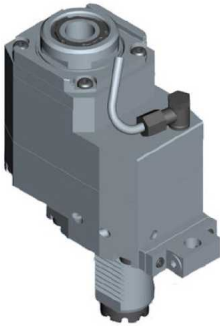

PartNumber	Description	Spindle	I	RPM	Cool Thru	Ext Cool
BAR0126132	Axial Geared-Up ERA32 Right Hand	ERA32	1:2	8000		X
BAR0126232	Axial Geared-Up ERA32 Right Hand Cool Thru*	ERA32	1:2	8000	X	X
BAR0127132	Axial Geared-Up ERA32 Left Hand	ERA32	1:2	8000		X
BAR0127232	Axial Geared-Up ERA32 Left Hand Cool Thru*	ERA32	1:2	8000	X	X

* Coolant Thru tools are designed for 1000 psi.
They require 5 Micron Filtration and **CANNOT** be run dry.

VDI40

DRIVEN

(0-180) ADJUSTABLE ANGLE DRIVEN TOOL VDI40 - RIGHT HAND

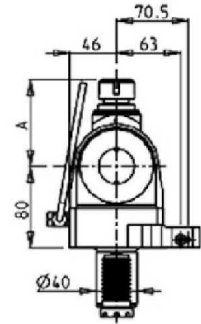
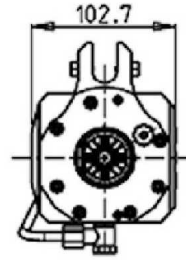
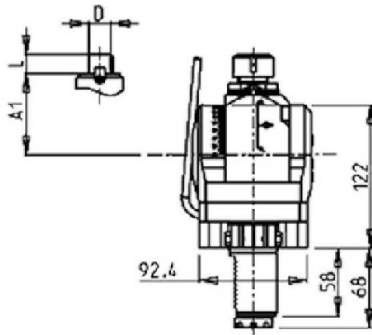
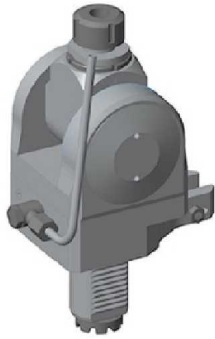

PartNumber	Description	Spindle	I	RPM	Ext Cool	A	A1	D	L
BAR0200120	(0-180) Adj. Angle ER20	ER20	1:1	4000	X	85.16			
BAR0200125	(0-180) Adj. Angle ER25	ER25	1:1	4000	X	86.16			
BAR0200519	(0-180) Adj. Angle 3/4"x3/4"	3/4"x3/4"	1:1	4000	X		65	3/4"	3/4"
BAR0200516	(0-180) Adj. Angle 16x17	16x17	1:1	4000	X		65	16	17
BAR0200522	(0-180) Adj. Angle 22x19	22x19	1:1	4000	X		66	22	19

Note : Wrenches are provided with the purchase of Specialty Toolholders

(0-180) ADJUSTABLE ANGLE DRIVEN TOOL WITH DIGITAL DISPLAY VDI40 - RIGHT HAND

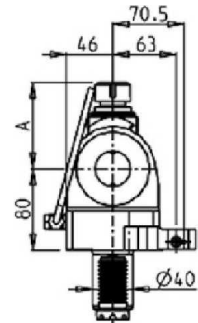
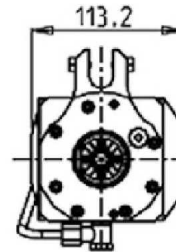
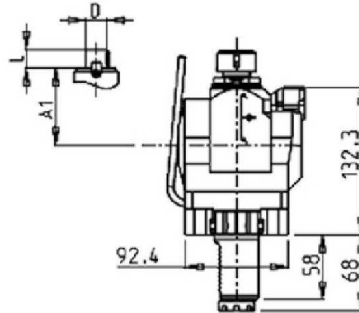

PartNumber	Description	Spindle	I	RPM	Ext Cool	A	A1	D	L
BAR0190120	(0-180) Adj. Angle ER20 with Digital Display	ER20	1:1	4000	X	85.16			
BAR0190125	(0-180) Adj. Angle ER25 with Digital Display	ER25	1:1	4000	X	86.16			
BAR0190519	(0-180) Adj. Angle 3/4"x3/4" with Digital Display	3/4"x3/4"	1:1	4000	X		65	3/4"	3/4"
BAR0190516	(0-180) Adj. Angle 16x17 with Digital Display	16x17	1:1	4000	X		65	16	17
BAR0190522	(0-180) Adj. Angle 22x19 with Digital Display	22x19	1:1	4000	X		66	22	19

Note : Wrenches are provided with the purchase of Specialty Toolholders

VDI40

DRIVEN

DRIVEN GEAR HOBBER VDI40

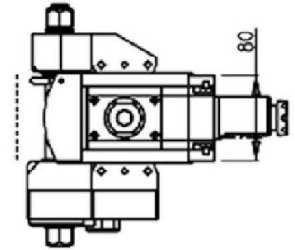
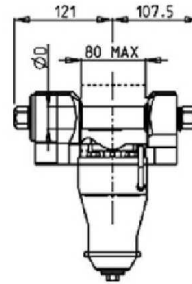
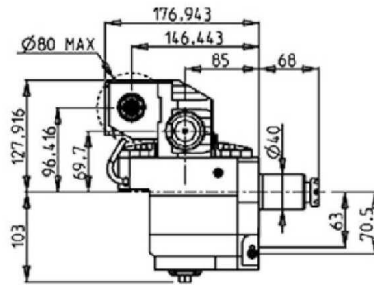
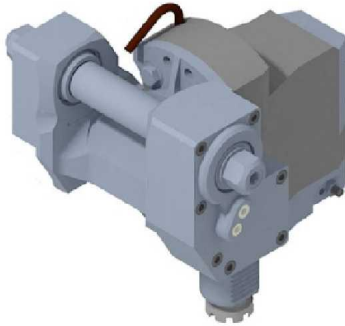

PartNumber	Description	I	RPM	Ext Cool	D (mm)	D (Inch)	VDI
BAR0231100	Driven Gear Hobb 1:1 Right Hand	1:1	6000	X	16-22-27-32	3/4" - 1" - 1-1/4"	Right Hand
BAR0232100	Driven Gear Hobb 2:1 Geared-Down Right Hand	2:1	3000	X	16-22-27-32	3/4" - 1" - 1-1/4"	Right Hand
BAR0231110	Driven Gear Hobb 1:1 Left Hand	1:1	6000	X	16-22-27-32	3/4" - 1" - 1-1/4"	Left Hand
BAR0232110	Driven Gear Hobb 2:1 Geared-Down Left Hand	2:1	3000	X	16-22-27-32	3/4" - 1" - 1-1/4"	Left Hand

Note : Wrenches are provided with the purchase of Specialty Toolholders

VDI40

DRIVEN

BROACHING/SLOTING DRIVEN TOOL 25mm STROKE VDI40

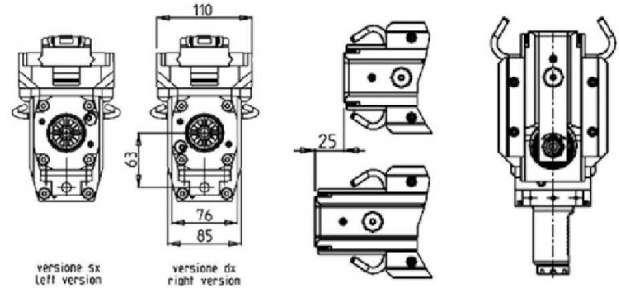
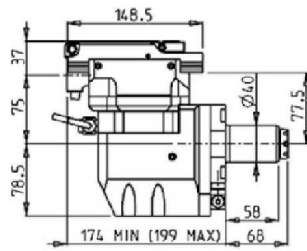
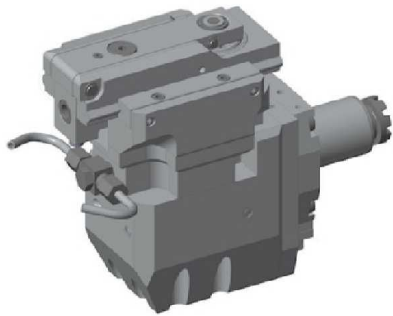

PartNumber	Description	I	MAX RPM	Ext Cool	VDI
BAR0180200	Broaching/Slotting 25mm Stroke Right Hand	4:1	2400	X	Right Hand
BAR0181200	Broaching/Slotting 25mm Stroke Left Hand	4:1	2400	X	Left Hand

BROACHING/SLOTING DRIVEN TOOL 50mm STROKE VDI40

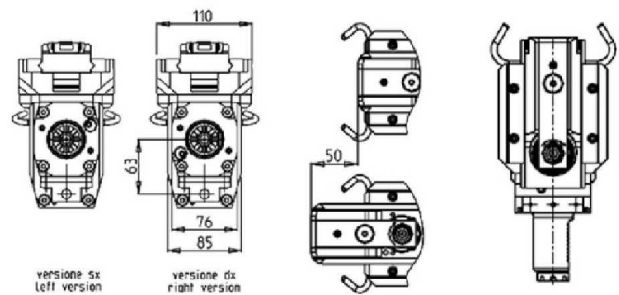
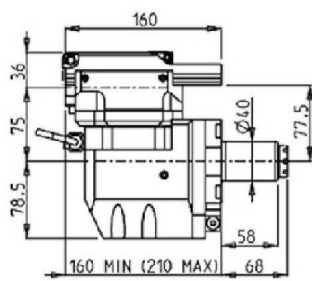
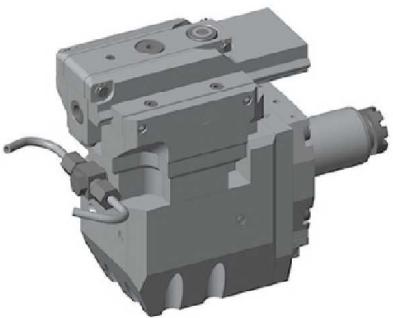

PartNumber	Description	I	MAX RPM	Ext Cool	VDI
BAR0180100	Broaching/Slotting 50mm Stroke Right Hand	4:1	2000	X	Right Hand
BAR0181100	Broaching/Slotting 50mm Stroke Left Hand	4:1	2000	X	Left Hand

VDI50

DRIVEN

RADIAL DRIVEN TOOL VDI50

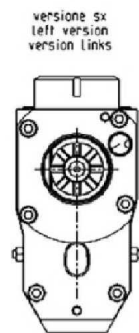
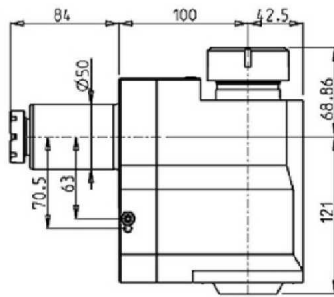

PartNumber	Description	Orientation	Spindle	I	RPM	Ext Cool
181BAR_R40_50C00	Radial VDI50 ER40 RH	Right Hand	ER40	1:1	4000	X
181BAR_R40_50C20	Radial VDI50 ER40 LH	Left Hand	ER40	1:1	4000	X

RADIAL DRIVEN TOOL FOR INTERNAL TOOLING VDI50

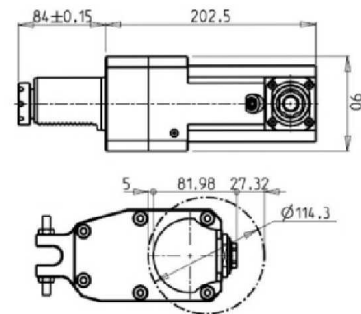
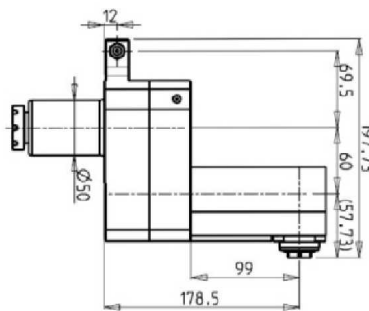
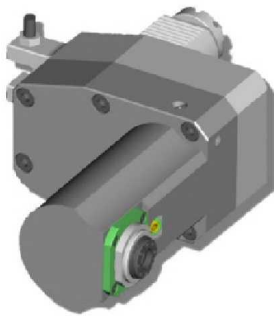

PartNumber	Description	Orientation	Spindle	I	MAX RPM	Ext Cool
BAR0010120	Radial ERA20 Right Hand	Right Hand	ERA20	1:1	4000	X

VDI50

DRIVEN

AXIAL DRIVEN TOOL VDI50

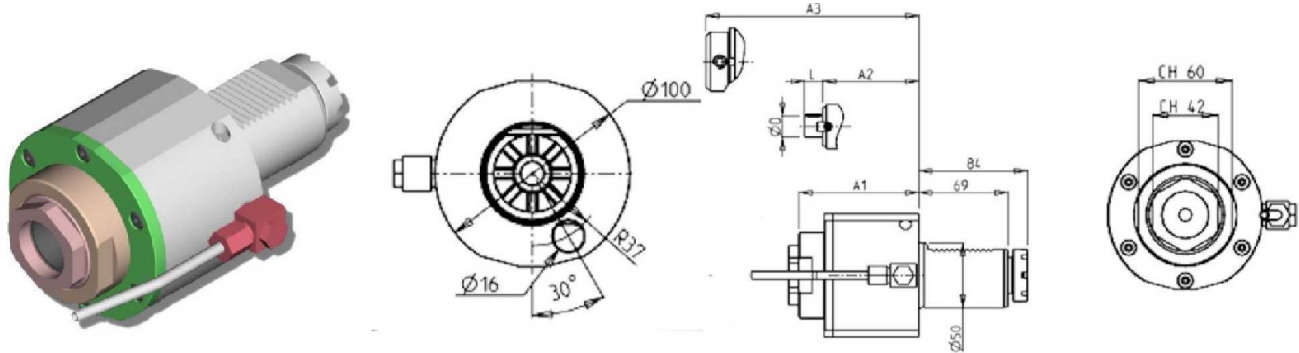

PartNumber	Description	Spindle	I	RPM	Cool Thru	Ext Cool	A1	A2	D	L
BAR0020140	Axial ERA40	ERA40	1:1	4000		X	92.5			
BAR0020240	Axial ERA40 Cool Thru*	ERA40	1:1	4000	X	X	92.5			
BAR0020522	Axial Milling Head 22x19	22x19	1:1	4000		X		88.5	22	19

*Coolant Thru tools are designed for 400 psi MAX.
They require 5 Micron Filtration and **CANNOT** be run dry.

AXIAL DRIVEN TOOL RE-DIRECTED BY 60mm VDI50

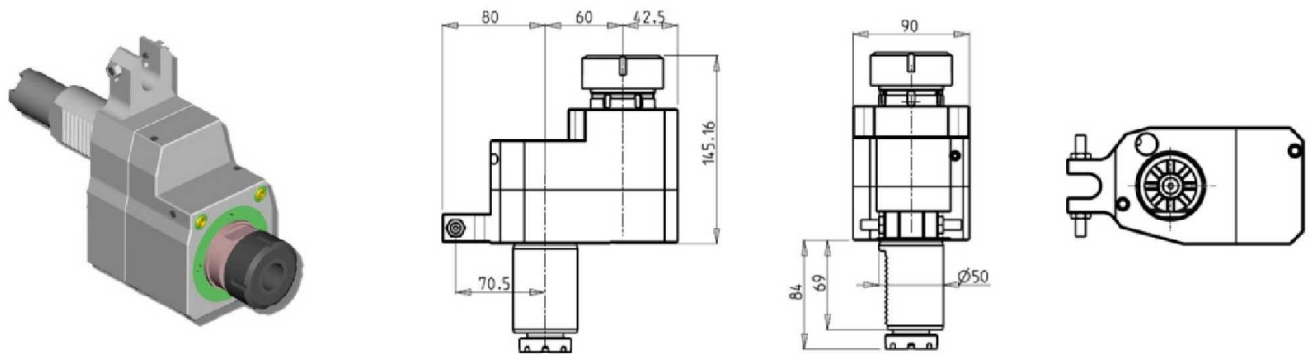

PartNumber	Description	Orientation	Spindle	I	RPM	Ext Cool
185BAR_A40_50C00	Axial ER40 Right Hand	Right Hand	ER40	1:1	4000	X

VDI50

DRIVEN

DRIVEN GEAR HOBBER VDI50 - RIGHT HAND

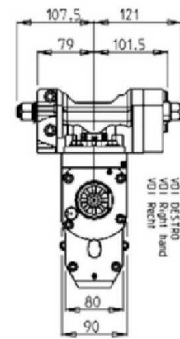
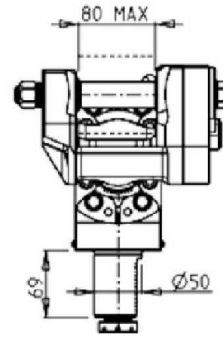
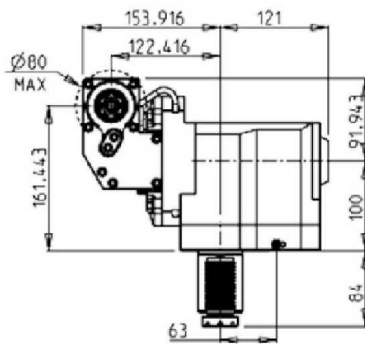
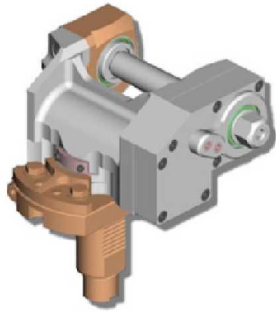

PartNumber	Description	I	MAX RPM	Ext Cool	D (mm)	D (Inch)
BAR0051100	Gear Hobber 1:1	1:1	4000	X	16-22-27-32	3/4"-1"-1 1/4"
BAR0052100	Gear Hobber 2:1 Geared-Down	2:1	2000	X	16-22-27-32	3/4"-1"-1 1/4"

Note : Wrenches are provided with the purchase of Specialty Toolholders

ACCESSORIES

DRIVEN

MTSK-32 ER ADAPTORS

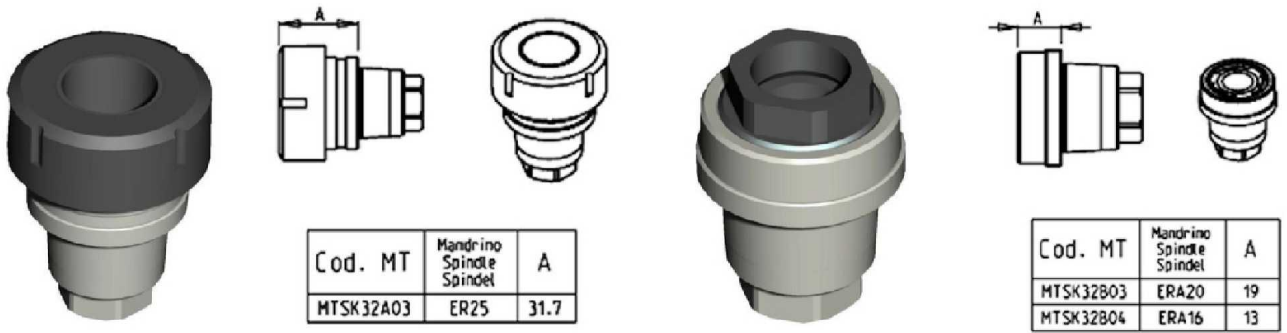

Cod. MT	Mandrino Spindle Spindel	A
MTSK32A03	ER25	31.7

Cod. MT	Mandrino Spindle Spindel	A
MTSK32B03	ERA20	19
MTSK32B04	ERA16	13

PartNumber	Description	Spindle	A
MTSK32B04	MTSK-32 Adaptor ERA16	ERA16	13
MTSK32B03	MTSK-32 Adaptor ERA20	ERA20	19
MTSK32A03	MTSK-32 Adaptor ER25	ER25	31.7

ACCESSORIES

DRIVEN

MTSK-32 MILL ADAPTORS

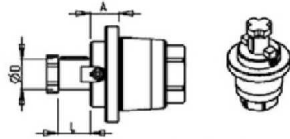

Cod. MT	Mandrin Spindle Spindel	Misure Dimensions Maße	A	D	L
MTSK32C02	∅16x17	mm	14	16	17

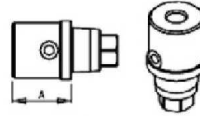

Cod. MT	Mandrin Spindle Spindel	A
MTSK32D01	WELDON 6	8
MTSK32D02	WELDON 8	10
MTSK32D03	WELDON 10	32
MTSK32D04	WELDON 12	34.5

Cod. MT	Tappo di protezione Cover Plug Abdeckstopfen
MTSK32T00	



PartNumber	Description	Spindle	Dimensions	A	D	L
MTSK32C02	MTSK-32 Adaptor Mill 16x17	16x17	mm	14	16	17
MTSK32D01	MTSK-32 Adaptor Weldon 6	Weldon 6		8		
MTSK32D02	MTSK-32 Adaptor Weldon 8	Weldon 8		10		
MTSK32D03	MTSK-32 Adaptor Weldon 10	Weldon 10		32		
MTSK32D04	MTSK-32 Adaptor Weldon 12	Weldon 12		34.5		
MTSK32T00	MTSK-32 Cover Plug					

ACCESSORIES

DRIVEN

MTSK-40 ER ADAPTORS

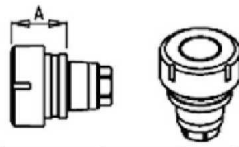

Cod. MT	Mandrino Spindel	A
MTSK40A02	ER32	35.6
MTSK40A03	ER25	32.6
MTSK40A05	ER16	30.26
MTSK40A06	ER16	47.5
MTSK40A07	ER16	59
MTSK40A08	ER11	40
MTSK40A09	ER11	70

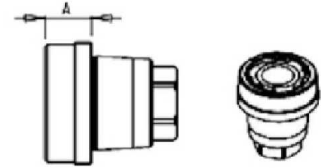

Cod. MT	Mandrino Spindel	A
MTSK40B02	ERA25	16
MTSK40B03	ERA20	14

PartNumber	Description	Spindle	A
MTSK40A08	MTSK-40 Adaptor ER11	ER11	40
MTSK40A09	MTSK-40 Adaptor ER11	ER11	70
MTSK40A05	MTSK-40 Adaptor ER16	ER16	30.26
MTSK40A06	MTSK-40 Adaptor ER16	ER16	47.5
MTSK40A07	MTSK-40 Adaptor ER16	ER16	59
MTSK40B03	MTSK-40 Adaptor ERA20	ERA20	14
MTSK40B02	MTSK-40 Adaptor ERA25	ERA25	16
MTSK40A03	MTSK-40 Adaptor ER25	ER25	32.6
MTSK40A02	MTSK-40 Adaptor ER32	ER32	35.6

ACCESSORIES

DRIVEN

MTSK-40 MILL ADAPTORS



Cod. MT	Mandrina Spindle Spindel	A
MTSK40D01	WELDON 6	8
MTSK40D21	WELDON 6	27.5
MTSK40D02	WELDON 8	8
MTSK40D03	WELDON 10	9
MTSK40D04	WELDON 12	14
MTSK40D05	WELDON 16	39.5
MTSK40D07	WELDON 20	39.5
MTSK40D24	WELDON 10	33
MTSK40D25	WELDON 12	35.5

Cod. MT	Mandrina Spindle Spindel	A
MTSK40G03	MR25	33.6

Cod. MT	Mandrina Spindle Spindel	Morsa Dimensione Morse	A	D	L
MTSK40D02	Ø 16mm	mm	16	16	17
MTSK40D03	Ø 22x19	inch	17	22	19
MTSK40D04	Ø 27x21	mm	22	27	21

Cod. MT	Mandrina Spindle Spindel	A
MTSK40D11	WELDON 1/4"	8
MTSK40D12	WELDON 5/16"	8
MTSK40D13	WELDON 3/8"	9
MTSK40D14	WELDON 1/2"	14

Cod. MT	Mandrina Spindle Spindel	A	D	L
MTSK40H01	MORSE-1	29	1/2"	6.5
MTSK40H02	MORSE-2	42	1/2"	6.5

Cod. MT	Mandrina Spindle Spindel	Morsa Dimensione Morse	A	D	L
MTSK40G01	Ø 1/2"	inch	16	1/2"	6.5

Cod. MT	MTSK40T00	A	D
MTSK40T00	Tappe in protezione Cover Plug Abdeckkappen		

PartNumber	Description	Spindle	Dimension	A	D	L
MTSK40C03	MTSK-40 Adaptor Mill 3/4"	3/4"x3/4"	Inch	15.5	3/4"	3/4"
MTSK40C02	MTSK-40 Adaptor Mill 16x17	16x17	mm	15	16	17
MTSK40C04	MTSK-40 Adaptor Mill 22x19	22x19	mm	17	22	19
MTSK40C05	MTSK-40 Adaptor Mill 27x21	27x21	mm	22	27	21
MTSK40F01	MTSK-40 Adaptor Mill 1/2"	1/2" Arbor	Inch	32	1/2"	6.5
MTSK40D11	MTSK-40 Adaptor Weldon 1/4"	Weldon 1/4"		8		
MTSK40D12	MTSK-40 Adaptor Weldon 5/16"	Weldon 5/16"		8		
MTSK40D13	MTSK-40 Adaptor Weldon 3/8"	Weldon 3/8"		9		
MTSK40D14	MTSK-40 Adaptor Weldon 1/2"	Weldon 1/2"		14		
MTSK40D01	MTSK-40 Adaptor Weldon 6	Weldon 6		8		
MTSK40D21	MTSK-40 Adaptor Weldon 6	Weldon 6		27.5		
MTSK40D02	MTSK-40 Adaptor Weldon 8	Weldon 8		8		
MTSK40D03	MTSK-40 Adaptor Weldon 10	Weldon 10		9		
MTSK40D24	MTSK-40 Adaptor Weldon 10	Weldon 10		33		
MTSK40D04	MTSK-40 Adaptor Weldon 12	Weldon 12		14		
MTSK40D25	MTSK-40 Adaptor Weldon 12	Weldon 12		35.5		
MTSK40D06	MTSK-40 Adaptor Weldon 16	Weldon 16		39.5		
MTSK40D07	MTSK-40 Adaptor Weldon 20	Weldon 20		39.5		
MTSK40H01	MTSK-40 Adaptor Morse 1	MORSE-1		29		
MTSK40H02	MTSK-40 Adaptor Morse 2	MORSE-2		42		
MTSK40G03	MTSK-40 Adaptor MR25	MR25		33.6		
MTSK40T00	MTSK-40 Cover Plug					

ACCESSORIES

DRIVEN

TOOL DISASSEMBLING EQUIPMENT FOR MTSK

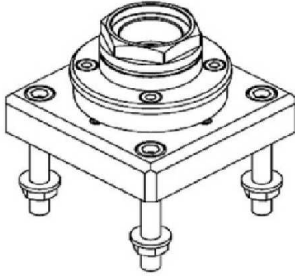

Cod. MT	TAGLIA Size Masse
ATT_MTSK32	MTSK-32
ATT_MTSK40	MTSK-40
ATT_MTSK50	MTSK-50
ATT_MTSK63	MTSK-63

PartNumber	Description	Size
ATT_MTSK32	Tool Disassembling Equipment for MTSK-32	MTSK-32
ATT_MTSK40	Tool Disassembling Equipment for MTSK-40	MTSK-40

ER COLLETS

ER COLLET NUMBER	DESCRIPTION	MD LIST PRICE
ER20 SET	ER20 Collet Set (15 Collets)	\$ 330.00
ERX20 SET	ER20 Sealed Collet Set (13 Collets)	\$ 395.00
ER25 SET	ER25 Collet Set (19 Collets)	\$ 375.00
ERX25 SET	ER25 Sealed Collet Set (17 Collets)	\$ 475.00
ER32 SET	ER32 Collet Set (21 Collets)	\$ 425.00
ERX32 SET	ER32 Sealed Collet Set (21 Collets)	\$ 595.00
ER40 SET	ER40 Collet Set (29 Collets)	\$ 695.00
ERX40 SET	ER40 Sealed Collet Set (27 Collets)	\$ 850.00



Phone: (810) 632-4446 / Fax: (810) 632-4467

Table of Contents

Alphabetized Listing

((0-180) ADJUSTABLE ANGLE DRIVEN TOOL VDI40 - RIGHT HAND	15
	(0-180) ADJUSTABLE ANGLE DRIVEN TOOL WITH DIGITAL	15
A		
	ACCESSORIES	21-25
	AXIAL DRIVEN TOOL RE-DIRECTED BY 42mm VDI40 - RIGHT HAND	19
	AXIAL DRIVEN TOOL RE-DIRECTED BY 60mm VDI50	19
	AXIAL DRIVEN TOOL VDI30	8
	AXIAL DRIVEN TOOL VDI40	12
	AXIAL DRIVEN TOOL VDI50	19
	AXIAL GEARED-DOWN 2:1 RE-DIRECTED BY 42mm VDI40 - RIGHT HAND	19
	AXIAL GEARED-UP 1:2 DRIVEN TOOL RE-DIRECTED BY 42mm VDI40	19
B		
	BROACHING/SLOTTING DRIVEN TOOL 25mm STROKE VDI40	17
	BROACHING/SLOTTING DRIVEN TOOL 50mm STROKE VDI40	17
D		
	DRIVEN	1-25
	DRIVEN GEAR HOBBER VDI40	16
	DRIVEN GEAR HOBBER VDI50 - RIGHT HAND	20
M		
	MTSK-32 ER ADAPTORS	21
	MTSK-32 MILL ADAPTORS	22
	MTSK-40 ER ADAPTORS	23
	MTSK-40 MILL ADAPTORS	24
Q		
	QUICK CHANGE AXIAL MTSK-40 DRIVEN TOOL VDI40	12
	QUICK CHANGE RADIAL MTSK-32 REAR SET DRIVEN TOOL VDI30	30
	QUICK CHANGE RADIAL MTSK-32 REAR SET DRIVEN TOOL VDI30	30
	QUICK CHANGE RADIAL MTSK-32 REAR SET DRIVEN TOOL VDI30	30
	QUICK CHANGE RADIAL MTSK-32 REAR SET DRIVEN TOOL VDI30	30
R		
	RADIAL DRIVEN TOOL FOR INTERNAL TOOLING VDI50	18
	RADIAL DRIVEN TOOL VDI30 - LEFT HAND	1
	RADIAL DRIVEN TOOL VDI30 - RIGHT HAND	1
	RADIAL DRIVEN TOOL VDI40 H=100mm - LEFT HAND	9
	RADIAL DRIVEN TOOL VDI40 H=100mm - RIGHT HAND	9
	RADIAL DRIVEN TOOL VDI50	18
	RADIAL GEARED-DOWN 2:1 REAR SET DRIVEN TOOL H=85mm	11
	RADIAL REAR-SET DRIVEN TOOL VDI30 H=75mm - LEFT HAND	3
	RADIAL REAR-SET DRIVEN TOOL VDI30 H=75mm - RIGHT HAND	2
	RADIAL REAR-SET DRIVEN TOOL VDI30 H=85mm - LEFT HAND	5
	RADIAL REAR-SET DRIVEN TOOL VDI30 H=85mm - RIGHT HAND	4
	RADIAL REAR-SET DRIVEN TOOL VDI40 H=85mm - LEFT HAND	10
	RADIAL REAR-SET DRIVEN TOOL VDI40 H=85mm - RIGHT HAND	10
T		
	TOOL DISASSEMBLING EQUIPMENT FOR MTSK	25
V		
	VDI30	1-8
	VDI40	9-17
	VDI50	18-20

Table of Contents

Part Number Index

1					
161BAR_R32_40C00	Radial Rear-Set ER32	10	BAR0081220	Radial Rear-Set ER20 Cool Thru*	3
161BAR_R32_40C20	Radial Rear-Set ER32	10	BAR0081225	Radial Rear-Set ER25 Cool Thru*	3
162BAR_A32_40C00	Axial ER32	12	BAR0081320	Radial Rear-Set ERA20	3
165BAR_A32_40C00	Axial Re-Directed ER32	13	BAR0081325	Radial Rear-Set ERA25	3
165BAR_A32_40C10	Axial Re-Directed ER32 Cool Thru*	13	BAR0081420	Radial Rear-Set ERA20 Cool Thru*	3
165BAR_A32_40C20	Axial Geared-Down ER32	13	BAR0081425	Radial Rear-Set ERA25 Cool Thru*	3
165BAR_A32_40C30	Axial Geared-Down ER32 Cool Thru*	13	BAR0081516	Radial Rear-Set Weldon16	3
181BAR_R40_50C00	Radial VDI50 ER40 RH	18	BAR0126132	Axial Geared-Up ERA32 Right Hand	14
181BAR_R40_50C20	Radial VDI50 ER40 LH	18	BAR0126232	Axial Geared-Up ERA32 Right Hand Cool Thru*	14
185BAR_A40_50C00	Axial ER40 Right Hand	19	BAR0127132	Axial Geared-Up ERA32 Left Hand	14
			BAR0127232	Axial Geared-Up ERA32 Left Hand Cool Thru*	14
A					
ATT_MTSK32	Tool Disassembling Equipment for MTSK-32	25	BAR0130420	Axial Weldon 20	12
ATT_MTSK40	Tool Disassembling Equipment for MTSK-40	25	BAR0150140	Radial Geared-Down ER40	11
			BAR0150240	Radial Geared-Down ER40 Cool Thru*	11
			BAR0160132	Radial MTSK-32	7
			BAR0160232	Radial MTSK-32 Cool Thru*	7
			BAR0161132	Radial MTSK-32	7
			BAR0161232	Radial MTSK-32 Cool Thru*	7
BAR0010120	Radial ERA20 Right Hand	18	BAR0170132	Radial MTSK-32	6
BAR0020140	Axial ERA40	19	BAR0170232	Radial MTSK-32 Cool Thru*	6
BAR0020240	Axial ERA40 Cool Thru*	19	BAR0171132	Radial MTSK-32	6
BAR0020522	Axial Milling Head 22x19	19	BAR0171232	Radial MTSK-32 Cool Thru*	6
BAR0040125	Axial Driven ER25	8	BAR0180100	Broaching/Slotting 50mm Stroke Right Hand	17
BAR0040225	Axial Driven ERA25	8			
BAR0040316	Axial Driven Weldon16	8	BAR0180200	Broaching/Slotting 25mm Stroke Right Hand	17
BAR0040416	Axial VDI30 Milling Head 16x17	8			
BAR0040422	Axial VDI30 Milling Head 22x19	8	BAR0181100	Broaching/Slotting 50mm Stroke Left Hand	17
BAR0041125	Axial Driven ER25 Cool Thru*	8			
BAR0041225	Axial Driven ERA25 Cool Thru*	8	BAR0181200	Broaching/Slotting 25mm Stroke Left Hand	17
BAR0041316	Axial Driven Weldon16 Cool Thru*	8			
BAR0051100	Gear Hobber 1:1	20	BAR0190120	(0-180) Adj. Angle ER20 with Digital Display	15
BAR0052100	Gear Hobber 2:1 Geared-Down	20	BAR0190125	(0-180) Adj. Angle ER25 with Digital Display	15
BAR0060125	Radial Driven ER25	1	BAR0190516	(0-180) Adj. Angle 16x17 with Digital Display	15
BAR0060225	Radial Driven ER25 Cool Thru*	1	BAR0190519	(0-180) Adj. Angle 3/4"x3/4" with Digital Display	15
BAR0060316	Radial Driven Weldon 16	1	BAR0190522	(0-180) Adj. Angle 22x19 with Digital Display	15
BAR0060416	Radial Milling Head 16x17	1	BAR0200120	(0-180) Adj. Angle ER20	15
BAR0060422	Radial Milling Head 22x19	1	BAR0200125	(0-180) Adj. Angle ER25	15
BAR0061125	Radial Driven ER25	1	BAR0200516	(0-180) Adj. Angle 16x17	15
BAR0061225	Radial Driven ER25 Cool Thru*	1	BAR0200519	(0-180) Adj. Angle 3/4"x3/4"	15
BAR0061316	Radial Driven Weldon 16	1	BAR0200522	(0-180) Adj. Angle 22x19	15
BAR0061416	Radial Milling Head 16x17	1	BAR0210132	Radial ER32 VDI40	9
BAR0061422	Radial Milling Head 22x19	1	BAR0210140	Radial ER40 VDI40	9
BAR0070120	Radial Rear-Set ER20	4	BAR0210232	Radial ER32 VDI40 Cool Thru*	9
BAR0070125	Radial Rear-Set ER25	4	BAR0210240	Radial ER40 VDI40 Cool Thru*	9
BAR0070220	Radial Rear-Set ER20 Cool Thru*	4	BAR0210522	Radial Milling Head 22x19 VDI40	9
BAR0070225	Radial Rear-Set ER25 Cool Thru*	4	BAR0210527	Radial Milling Head 27x21 VDI40	9
BAR0070320	Radial Rear-Set ERA20	4	BAR0211132	Radial ER32 VDI40	9
BAR0070325	Radial Rear-Set ERA25	4	BAR0211140	Radial ER40 VDI40	9
BAR0070420	Radial Rear-Set ERA20 Cool Thru*	4	BAR0211232	Radial ER32 VDI40 Cool Thru*	9
BAR0070425	Radial Rear-Set ERA25 Cool Thru*	4	BAR0211240	Radial ER40 VDI40 Cool Thru*	9
BAR0070516	Radial Rear-Set Weldon16	4	BAR0211522	Radial Milling Head 22x19 VDI40	9
BAR0071120	Radial Rear-Set ER20	5	BAR0211527	Radial Milling Head 27x21 VDI40	9
BAR0071125	Radial Rear-Set ER25	5	BAR0220140	Axial MTSK-40	12
BAR0071220	Radial Rear-Set ER20 Cool Thru*	5	BAR0231100	Driven Gear Hobb 1:1 Right Hand	16
BAR0071225	Radial Rear-Set ER25 Cool Thru*	5	BAR0231110	Driven Gear Hobb 1:1 Left Hand	16
BAR0071320	Radial Rear-Set ERA20	5	BAR0232100	Driven Gear Hobb 2:1 Geared-Down Right Hand	16
BAR0071325	Radial Rear-Set ERA25	5			
BAR0071420	Radial Rear-Set ERA20 Cool Thru*	5	BAR0232110	Driven Gear Hobb 2:1 Geared-Down Left Hand	16
BAR0071425	Radial Rear-Set ERA25 Cool Thru*	5			
BAR0071516	Radial Rear-Set Weldon16	5	BAR0240232	Axial ER32 Cool Thru*	12
BAR0080120	Radial Rear-Set ER20	2			
BAR0080125	Radial Rear-Set ER25	2	M		
BAR0080220	Radial Rear-Set ER20 Cool Thru*	2	MTSK32A03	MTSK-32 Adaptor ER25	21
BAR0080225	Radial Rear-Set ER25 Cool Thru*	2	MTSK32B03	MTSK-32 Adaptor ERA20	21
BAR0080320	Radial Rear-Set ERA20	2	MTSK32B04	MTSK-32 Adaptor ERA16	21
BAR0080325	Radial Rear-Set ERA25	2	MTSK32C02	MTSK-32 Adaptor Mill 16x17	22
BAR0080420	Radial Rear-Set ERA20 Cool Thru*	2			
BAR0080425	Radial Rear-Set ERA25 Cool Thru*	2			
BAR0080516	Radial Rear-Set Weldon16	2			
BAR0081120	Radial Rear-Set ER20	3			
BAR0081125	Radial Rear-Set ER25	3			

Table of Contents

Part Number Index

MTSK32D01	MTSK-32 Adaptor Weldon 6	22
MTSK32D02	MTSK-32 Adaptor Weldon 8	22
MTSK32D03	MTSK-32 Adaptor Weldon 10	22
MTSK32D04	MTSK-32 Adaptor Weldon 12	22
MTSK32T00	MTSK-32 Cover Plug	22
MTSK40A02	MTSK-40 Adaptor ER32	23
MTSK40A03	MTSK-40 Adaptor ER25	23
MTSK40A05	MTSK-40 Adaptor ER16	23
MTSK40A06	MTSK-40 Adaptor ER16	23
MTSK40A07	MTSK-40 Adaptor ER16	23
MTSK40A08	MTSK-40 Adaptor ER11	23
MTSK40A09	MTSK-40 Adaptor ER11	23
MTSK40B02	MTSK-40 Adaptor ERA25	23
MTSK40B03	MTSK-40 Adaptor ERA20	23
MTSK40C02	MTSK-40 Adaptor Mill 16x17	24
MTSK40C03	MTSK-40 Adaptor Mill 3/4"	24
MTSK40C04	MTSK-40 Adaptor Mill 22x19	24
MTSK40C05	MTSK-40 Adaptor Mill 27x21	24
MTSK40D01	MTSK-40 Adaptor Weldon 6	24
MTSK40D02	MTSK-40 Adaptor Weldon 8	24
MTSK40D03	MTSK-40 Adaptor Weldon 10	24
MTSK40D04	MTSK-40 Adaptor Weldon 12	24
MTSK40D06	MTSK-40 Adaptor Weldon 16	24
MTSK40D07	MTSK-40 Adaptor Weldon 20	24
MTSK40D11	MTSK-40 Adaptor Weldon 1/4"	24
MTSK40D12	MTSK-40 Adaptor Weldon 5/16"	24
MTSK40D13	MTSK-40 Adaptor Weldon 3/8"	24
MTSK40D14	MTSK-40 Adaptor Weldon 1/2"	24
MTSK40D21	MTSK-40 Adaptor Weldon 6	24
MTSK40D24	MTSK-40 Adaptor Weldon 10	24
MTSK40D25	MTSK-40 Adaptor Weldon 12	24
MTSK40F01	MTSK-40 Adaptor Mill 1/2"	24
MTSK40G03	MTSK-40 Adaptor MR25	24
MTSK40H01	MTSK-40 Adaptor Morse 1	24
MTSK40H02	MTSK-40 Adaptor Morse 2	24
MTSK40T00	MTSK-40 Cover Plug	24