

DRIVEN and STATIC TOOLING
For
NEXTURN



10139 BERGIN RD.
HOWELL, MI 48843
PHONE : 877-91-TOOLS (810-632-4446)
FAX: 877-92-TOOLS (810-632-4467)
EMAIL: info@mdtooling.com
WEBSITE: www.mdtooling.com

Live Tooling



M. T. Marchetti, a major live tool manufacturer in northern Italy, is a leader in live tool technology. The formula is simple. Use only the best angular contact high-speed bearings available. Add to this an exacting tolerances for all ground shafts, gears and bearing pocket features. Next, develop a sealed system that **will not** allow any contamination from chips or coolant.

Top this all off with a superior design and you end up with a live tool that is more rigid, faster and will last longer. **We back this up with a 2-Year factory warranty.**

Our Live Tool Warranty

Our tooling will give years of service in the most demanding applications. The superior design and rugged construction has proven this over the last 12 years. The reliability of our tools allows us to provide a 2-year factory warranty, for non-wear components.

MD Tooling will repair any defective tool holders for a period of 2 years from the date of purchase.

Product Range

We have the largest range of live tooling available for most major machine tool manufactures.

Our available products include an extensive line of standard live tooling as well as specialty tool holders such as 0-180 adjustable angle tool holders, gear hobbors, and even worm gear generators. Our product range includes geared up holders to 60,000 RPM and are engineered for 1,000 PSI coolant through.

We are an industry leader in providing complete tooling solutions with hundreds of static tool options as well.

Technical Support

Here at MD Tooling we have a full technical support department with over 35 years of CNC experience.

Our highly qualified staff can help with part processing, tooling up a job from a blue print and even assist with part programming. Applications Engineers are always available by phone to answer any questions you may have about our tooling or any other CNC related issue.

Stock and Replenishment

MD Tooling maintains an extensive inventory of tooling in our warehouse in Michigan. Our current "fill" rate on orders is 93% from our stock in Michigan for same day shipping.

Should you require a non-stock item, our manufacturer, M.T. Marchetti also maintains a large inventory in Italy. Tooling can be obtained in as little as 3-5 business days.

Shipping

MD Tooling realizes that when you need tooling, often you can't wait until the next day. We process orders and ship from available stock right up until 4PM EST to make certain we get your tooling solutions to you as quickly as possible.

We regularly ship throughout the day via UPS, FedEx or any other carrier that a customer requests.



10139 Bergin Road
Howell, MI 48843
Phone: (810) 632-4446
Fax: (810) 632-4467
Email: info@mdtooling.com
Web: www.mdtooling.com

- Fast, Friendly, Reliable Service!
- Quality tooling at highly competitive pricing.
- 2-Year Warranty on all live tools.
- Extensive inventory. We currently ship over 93% of all orders same day.
- In-house repair services available.
- If a warranty tool needs to be returned for inspection, service or repair, loaner tools are available to keep your machine tool production up and running.
- More specialty tool holders than any other manufacturer.
- Custom tool holders available.
- All available tooling may not be shown in this catalog. If you can't find the holder you're looking for, please contact our office for assistance.



Table of Contents

Categorized Listing

NST 56/67 (BMT45)	1
DRIVEN	1
RADIAL DRIVEN TOOL	1
QUICK CHANGE RADIAL MTSK DRIVEN TOOL	1
RADIAL DRIVEN TOOL REDIRECTED IN Z BY 36mm	2
RADIAL GEARED-UP 1:2 DRIVEN TOOL REDIRECTED IN Z BY 36mm	2
RADIAL GEARED-UP 1:3 DRIVEN TOOL REDIRECTED IN Z BY 36mm	3
RADIAL SINGLE SIDE TWIN HEAD DRIVEN TOOL IN Y	3
AXIAL REAR-SET DRIVEN TOOL	4
0-180° ADJUSTABLE ANGLE DRIVEN TOOL	4
STATIC	5
RADIAL SINGLE STATIC TOOL	5
RADIAL SINGLE SIDE TWIN STATIC TOOL	5
AXIAL SINGLE REAR-SET BORING BAR HOLDER	6
AXIAL 3 POSITION REAR-SET BORING BAR HOLDER	6
SA20/26/32/38 - SA20XII - SA32XIII	7
DRIVEN	7
AXIAL DRIVEN TOOL	7
ACCESSORIES	8
DRIVEN	8
MTSK-32 ER ADAPTORS	8
MTSK-32 MILL ADAPTORS	8
TOOL DISASSEMBLING EQUIPMENT FOR MTSK	9

NST 56/67 (BMT45)

DRIVEN

RADIAL DRIVEN TOOL

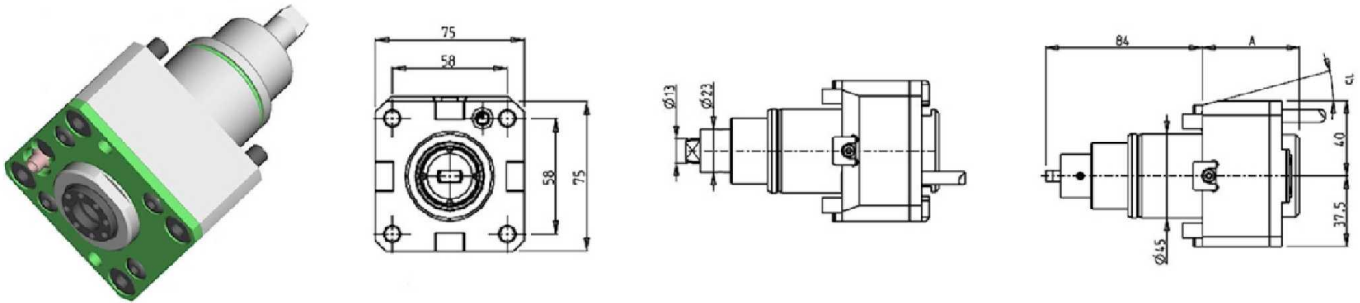

Part Number	Description	Spindle	I	RPM	Cool Thru	Ext Cool	A
DWO 2000325	Radial Driven Tool ERA25	ERA25	1:1	6000		X	52
DWO 3520425	Radial Driven Tool ERA25 Cool Thru*	ERA25	1:1	6000	X	X	56

* Coolant Thru tools are designed for 1000 psi.
They require 5 Micron Filtration and **CANNOT** be run dry.

QUICK CHANGE RADIAL MTSK DRIVEN TOOL

See Accessories for MTSK Quick Change Tool Holder Clamps

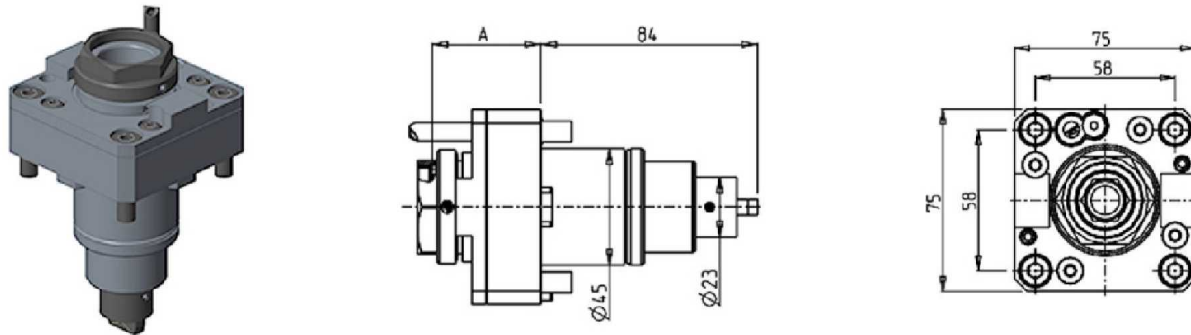

Part Number	Description	Spindle	I	RPM	Cool Thru	Ext Cool	A
DWO 3380132	Radial MTSK-32 Driven Tool	MTSK-32	1:1	6000		X	50.5
DWO 3380232	Radial MTSK-32 Driven Tool Cool Thru*	MTSK-32	1:1	6000	X	X	60

* Coolant Thru tools are designed for 1000 psi.
They require 5 Micron Filtration and **CANNOT** be run dry.

NST 56/67 (BMT45)

DRIVEN

RADIAL DRIVEN TOOL REDIRECTED IN Z BY 36mm

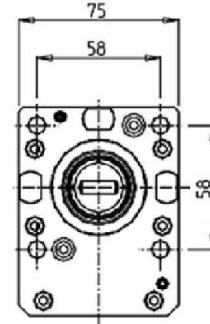
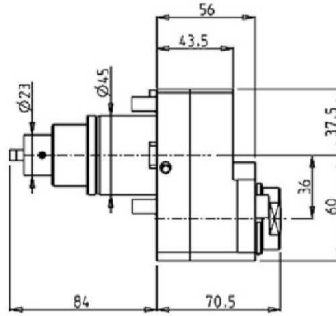
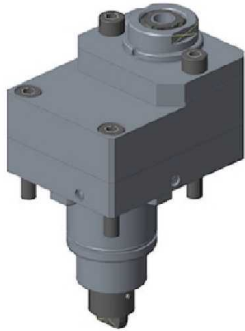

Part Number	Description	Spindle	I	RPM	Reversible	Cool Thru	Ext Cool
DWO 1890316	Radial Redirected ERA16 in Z by 36mm	ERA16	1:1	6000	X		X
DWO 1890416	Radial Redirected ERA16 in Z by 36mm Cool Thru*	ERA16	1:1	6000	X	X	X

* Coolant Thru tools are designed for 1000 psi.
They require 5 Micron Filtration and **CANNOT** be run dry.

RADIAL GEARED-UP 1:2 DRIVEN TOOL REDIRECTED IN Z BY 36mm

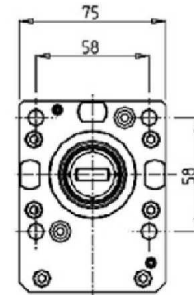
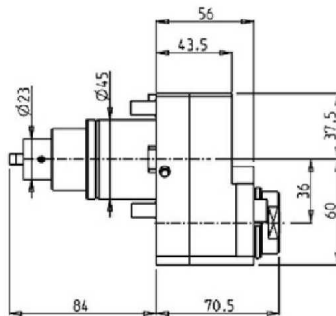
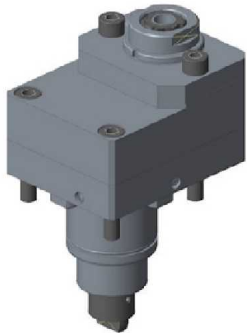

Part Number	Description	Spindle	I	RPM	Reversible	Cool Thru	Ext Cool
DWO 1891316	Radial Redirected Geared-Up 1:2 ERA16	ERA16	1:2	12000	X		X
DWO 1891416	Radial Redirected Geared-Up 1:2 ERA16 Cool Thru*	ERA16	1:2	12000	X	X	X

* Coolant Thru tools are designed for 1000 psi.
They require 5 Micron Filtration and **CANNOT** be run dry.

NST 56/67 (BMT45)

DRIVEN

RADIAL GEARED-UP 1:3 DRIVEN TOOL REDIRECTED IN Z BY 36mm

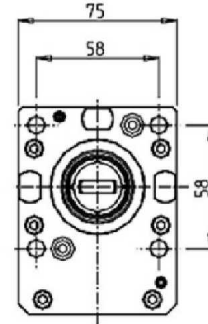
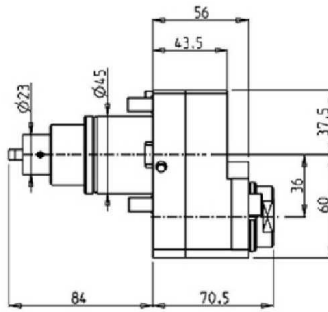
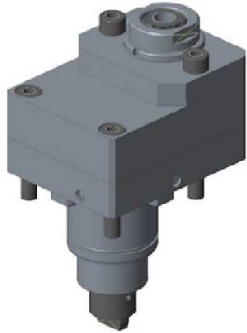

Part Number	Description	Spindle	I	RPM	Reversible	Cool Thru	Ext Cool
DWO 1892316	Radial Redirected Geared-Up 1:3 ERA16	ERA16	1:3	18000	X		X
DWO 1892416	Radial Redirected Geared-Up 1:3 ERA16 Cool Thru*	ERA16	1:3	18000	X	X	X

* Coolant Thru tools are designed for 1000 psi.
They require 5 Micron Filtration and **CANNOT** be run dry.

RADIAL SINGLE SIDE TWIN HEAD DRIVEN TOOL IN Y

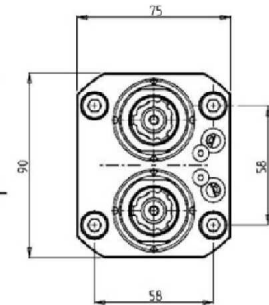
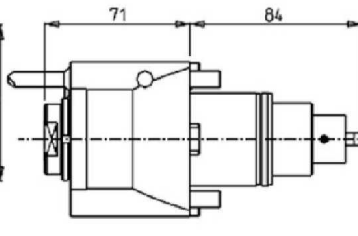
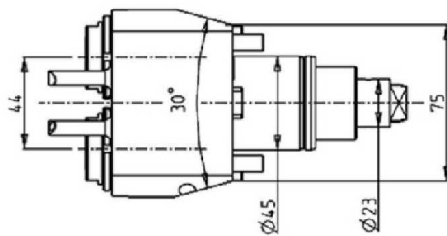
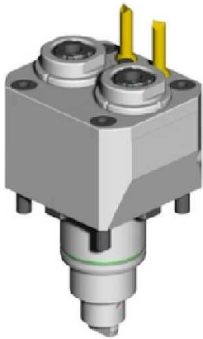

Part Number	Description	Spindle	I	RPM	Ext Cool
DWO 1460216	Radial Single Side Twin Head ERA16	ERA16	1:1	6000	X

NST 56/67 (BMT45)

DRIVEN

AXIAL REAR-SET DRIVEN TOOL

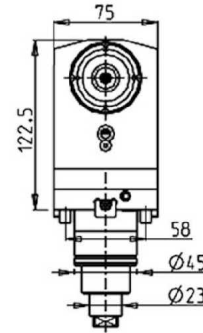
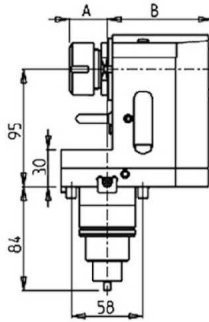

Part Number	Description	Spindle	I	RPM	Cool Thru	Ext Cool	A	B
DWO 0970320	Axial Rear-Set ERA20	ERA20	1:1	6000		X	13	85
DWO 0970420	Axial Rear-Set ERA20 Cool Thru*	ERA20	1:1	6000	X	X	13	95
DWO 0970125	Axial Rear-Set ER25	ER25	1:1	6000		X	30.66	85
DWO 0970225	Axial Rear-Set ER25 Cool Thru*	ER25	1:1	6000	X	X	30.66	95

* Coolant Thru tools are designed for 1000 psi.
They require 5 Micron Filtration and **CANNOT** be run dry.

0-180° ADJUSTABLE ANGLE DRIVEN TOOL

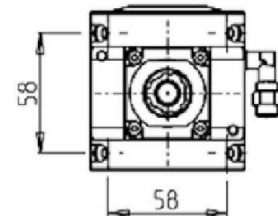
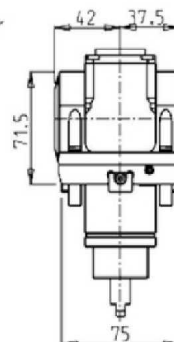
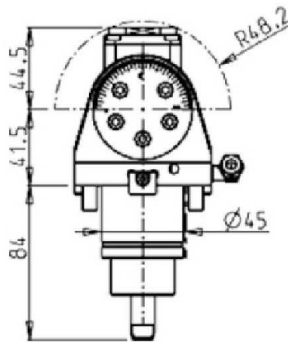
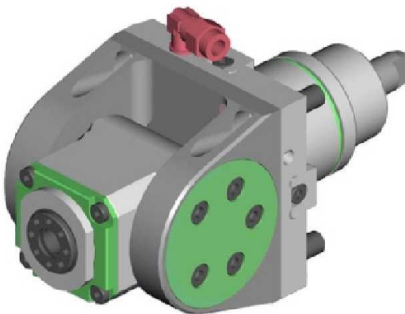

Part Number	Description	Spindle	I	RPM	Reversible	Ext Cool
DWO 0040116	0-180° Adjustable Angle ERA16	ERA16	1:1	6000	X	X

Note : Wrenches are provided with the purchase of Specialty Toolholders

NST 56/67 (BMT45)

STATIC

RADIAL SINGLE STATIC TOOL

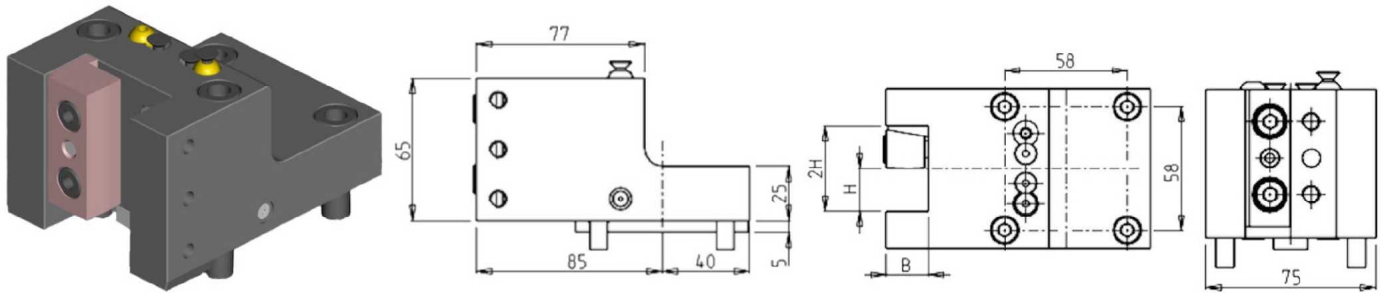

Part Number	Description	# of Tools	Reversible	Dimensions	H	B
DWO 1022000	Radial Single Static Tool 20mm	1/2	X	mm	20	20

RADIAL SINGLE SIDE TWIN STATIC TOOL

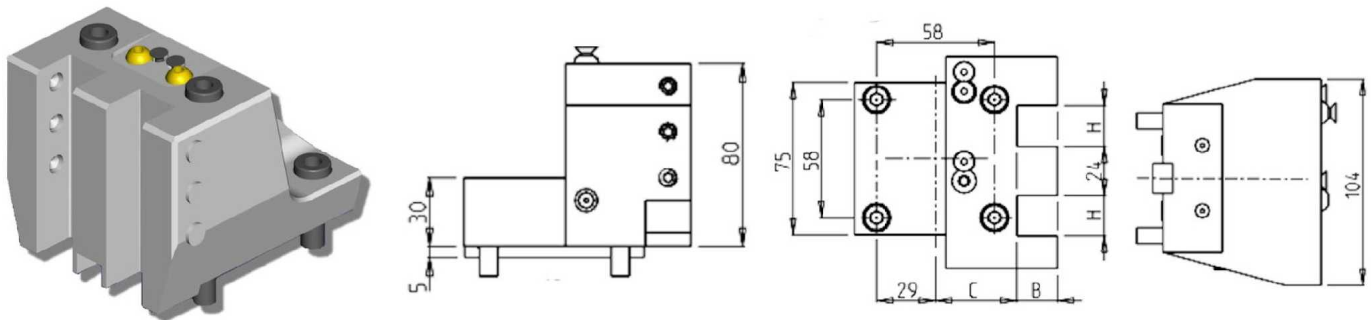

Part Number	Description	# of Tools	Reversible	Dimensions	B	H	C
DWO 0981905	Radial Single Side Twin Static 3/4"	2	X	Inch	3/4"	3/4"	40.95
DWO 0982000	Radial Single Side Twin Static 20mm	2	X	mm	20	20	40

NST 56/67 (BMT45)

STATIC

AXIAL SINGLE REAR-SET BORING BAR HOLDER

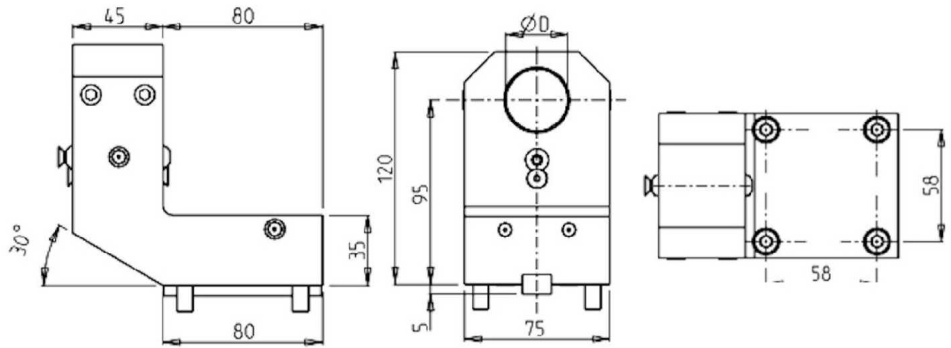
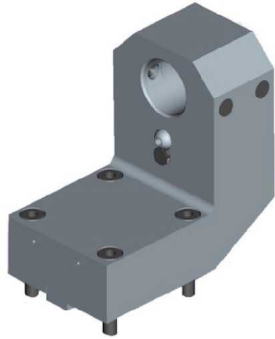

Part Number	Description	# of Tools	Reversible	Ext Cool	Dimensions	D
DWO 1093175	Axial Single Rear-Set BBH 1-1/4"	1	X	X	Inch	1-1/4"
DWO 1093200	Axial Single Rear-Set BBH 32mm	1	X	X	mm	32

AXIAL 3 POSITION REAR-SET BORING BAR HOLDER

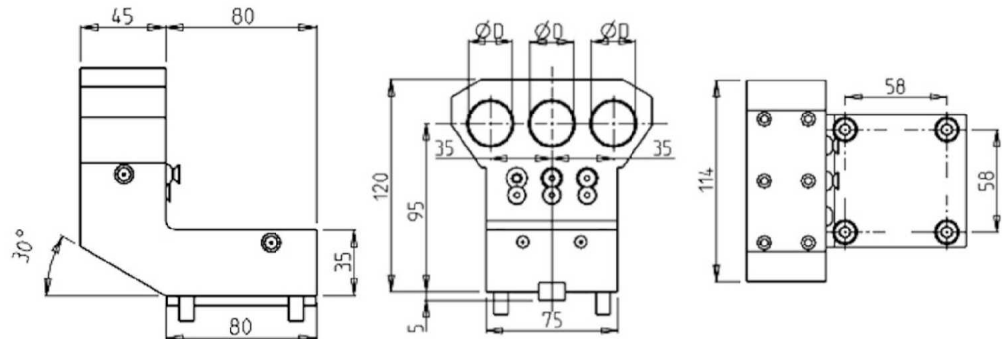
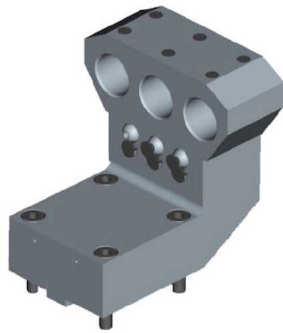

Part Number	Description	# of Tools	Reversible	Ext Cool	Dimensions	D
DWO 0992540	Axial 3 Position Rear-Set BBH 1"	3	X	X	Inch	1"
DWO 0992500	Axial 3 Position Rear-Set BBH 25mm	3	X	X	mm	25

SA20/26/32/38 - SA20XII - SA32XIII

DRIVEN

AXIAL DRIVEN TOOL

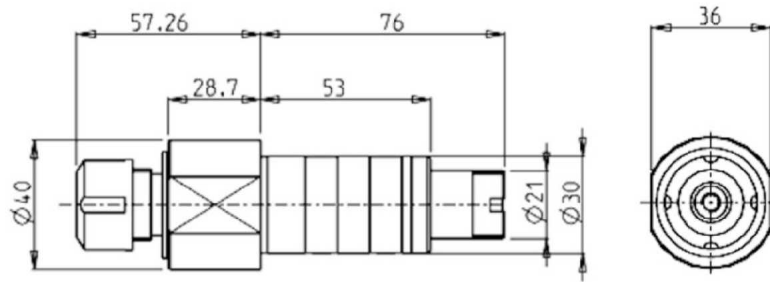

Part Number	Description	Spindle	I	RPM	Reversible	Ext Cool
NXT0010116	Axial Driven Tool ER16	ER16	1:1	8000	X	X

ACCESSORIES

DRIVEN

MTSK-32 ER ADAPTORS

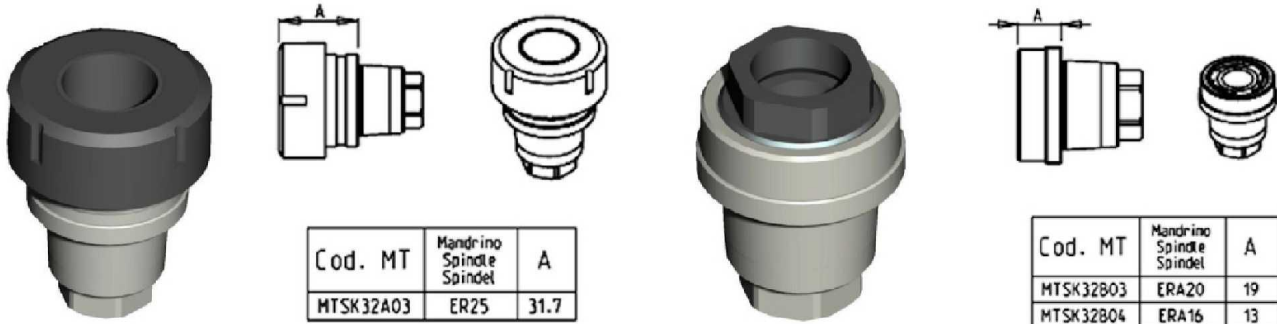

Cod. MT	Mandrino Spindel	A
MTSK32A03	ER25	31.7

Cod. MT	Mandrino Spindel	A
MTSK32B03	ERA20	19
MTSK32B04	ERA16	13

Part Number	Description	Spindle	A
MTSK32B04	MTSK-32 Adaptor ERA16	ERA16	13
MTSK32B03	MTSK-32 Adaptor ERA20	ERA20	19
MTSK32A03	MTSK-32 Adaptor ER25	ER25	31.7

MTSK-32 MILL ADAPTORS

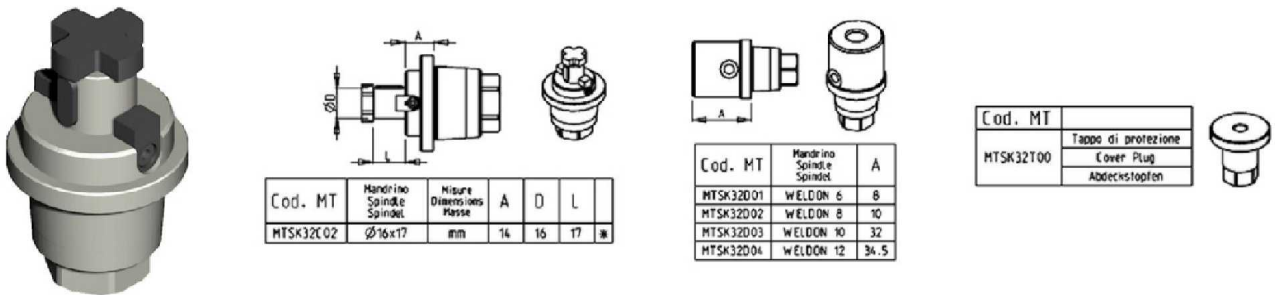

Cod. MT	Mandrino Spindel	Misure Diametri/Insi Masse	A	D	L
MTSK32C02	Ø16x17	mm	14	16	17

Cod. MT	Mandrino Spindel	A
MTSK32D01	WELDON 6	8
MTSK32D02	WELDON 8	10
MTSK32D03	WELDON 10	32
MTSK32D04	WELDON 12	34.5

Cod. MT	Tappo di protezione Cover Plug Abdeckstopfen
MTSK32T00	

Part Number	Description	Spindle	Dimensions	A	D	L
MTSK32C02	MTSK-32 Adaptor Mill Ø16x17mm	Ø16x17	mm	14	16	17
MTSK32D01	MTSK-32 Adaptor Mill Weldon 6	Weldon 6		8		
MTSK32D02	MTSK-32 Adaptor Mill Weldon 8	Weldon 8		10		
MTSK32D03	MTSK-32 Adaptor Mill Weldon 10	Weldon 10		32		
MTSK32D04	MTSK-32 Adaptor Mill Weldon 12	Weldon 12		34.5		
MTSK32T00	MTSK-32 Cover Plug					

ACCESSORIES

DRIVEN

TOOL DISASSEMBLING EQUIPMENT FOR MTSK

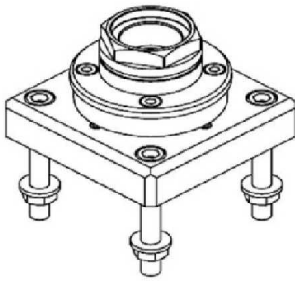

Cod. MT	TAGLIA Size Masse
ATT_MTSK32	MTSK-32
ATT_MTSK40	MTSK-40
ATT_MTSK50	MTSK-50
ATT_MTSK63	MTSK-63

Part Number	Description	Size
ATT_MTSK32	Tool Disassembling Equipment for MTSK32	MTSK-32

ER COLLETS

ER COLLET NUMBER	DESCRIPTION	MD LIST PRICE
ER20 SET	ER20 Collet Set (15 Collets)	\$ 330.00
ERX20 SET	ER20 Sealed Collet Set (13 Collets)	\$ 395.00
ER25 SET	ER25 Collet Set (19 Collets)	\$ 375.00
ERX25 SET	ER25 Sealed Collet Set (17 Collets)	\$ 475.00
ER32 SET	ER32 Collet Set (21 Collets)	\$ 425.00
ERX32 SET	ER32 Sealed Collet Set (21 Collets)	\$ 595.00
ER40 SET	ER40 Collet Set (29 Collets)	\$ 695.00
ERX40 SET	ER40 Sealed Collet Set (27 Collets)	\$ 850.00



Phone: (810) 632-4446 / Fax: (810) 632-4467

Table of Contents

Alphabetized Listing

O		
0-180° ADJUSTABLE ANGLE DRIVEN TOOL		4
A		
ACCESSORIES		8-9
AXIAL 3 POSITION REAR-SET BORING BAR HOLDER		6
AXIAL DRIVEN TOOL		7
AXIAL REAR-SET DRIVEN TOOL		4
AXIAL SINGLE REAR-SET BORING BAR HOLDER		6
D		
DRIVEN		1-4, 7-9
M		
MTSK-32 ER ADAPTORS		8
MTSK-32 MILL ADAPTORS		8
N		
NST 56/67 (BMT45)		1-6
Q		
QUICK CHANGE RADIAL MTSK DRIVEN TOOL		1
R		
RADIAL DRIVEN TOOL		1
RADIAL DRIVEN TOOL REDIRECTED IN Z BY 36mm		2
RADIAL GEARED-UP 1:2 DRIVEN TOOL REDIRECTED IN Z BY 36mm		2
RADIAL GEARED-UP 1:3 DRIVEN TOOL REDIRECTED IN Z BY 36mm		3
RADIAL SINGLE SIDE TWIN HEAD DRIVEN TOOL IN Y		3
RADIAL SINGLE SIDE TWIN STATIC TOOL		5
RADIAL SINGLE STATIC TOOL		5
S		
SA20/26/32/38 - SA20XII - SA32XIII		7
See Accessories for MTSK Quick Change Tool Holder Clamps		1
STATIC		5-6
T		
TOOL DISASSEMBLING EQUIPMENT FOR MTSK		9

Table of Contents

Part Number Index

A

ATT_MTSK32	Tool Disassembling Equipment for MTSK32	9
------------	---	---

D

DWO 0040116	0-180° Adjustable Angle ERA16	4
DWO 0970125	Axial Rear-Set ER25	4
DWO 0970225	Axial Rear-Set ER25 Cool Thru*	4
DWO 0970320	Axial Rear-Set ERA20	4
DWO 0970420	Axial Rear-Set ERA20 Cool Thru*	4
DWO 0981905	Radial Single Side Twin Static 3/4"	5
DWO 0982000	Radial Single Side Twin Static 20mm	5
DWO 0992500	Axial 3 Position Rear-Set BBH 25mm	6
DWO 0992540	Axial 3 Position Rear-Set BBH 1"	6
DWO 1022000	Radial Single Static Tool 20mm	5
DWO 1093175	Axial Single Rear-Set BBH 1-1/4"	6
DWO 1093200	Axial Single Rear-Set BBH 32mm	6
DWO 1460216	Radial Single Side Twin Head ERA16	3
DWO 1890316	Radial Redirected ERA16 in Z by 36mm	2
DWO 1890416	Radial Redirected ERA16 in Z by 36mm Cool Thru*	2
DWO 1891316	Radial Redirected Geared-Up 1:2 ERA16	2
DWO 1891416	Radial Redirected Geared-Up 1:2 ERA16 Cool Thru*	2
DWO 1892316	Radial Redirected Geared-Up 1:3 ERA16	3
DWO 1892416	Radial Redirected Geared-Up 1:3 ERA16 Cool Thru*	3
DWO 2000325	Radial Driven Tool ERA25	1
DWO 3380132	Radial MTSK-32 Driven Tool	1
DWO 3380232	Radial MTSK-32 Driven Tool Cool Thru*	1
DWO 3520425	Radial Driven Tool ERA25 Cool Thru*	1

M

MTSK32A03	MTSK-32 Adaptor ER25	8
MTSK32B03	MTSK-32 Adaptor ERA20	8
MTSK32B04	MTSK-32 Adaptor ERA16	8
MTSK32C02	MTSK-32 Adaptor Mill Ø16x17mm	8
MTSK32D01	MTSK-32 Adaptor Mill Weldon 6	8
MTSK32D02	MTSK-32 Adaptor Mill Weldon 8	8
MTSK32D03	MTSK-32 Adaptor Mill Weldon 10	8
MTSK32D04	MTSK-32 Adaptor Mill Weldon 12	8
MTSK32T00	MTSK-32 Cover Plug	8

N

NXT0010116	Axial Driven Tool ER16	7
------------	------------------------	---