

DRIVEN and STATIC TOOLING

For

TAKISAWA



10139 BERGIN RD.

HOWELL, MI 48843

PHONE : 877-91-TOOLS (810-632-4446)

FAX: 877-92-TOOLS (810-632-4467)

EMAIL: info@mdtooling.com

WEBSITE: www.mdtooling.com

Live Tooling



M. T. Marchetti, a major live tool manufacturer in northern Italy, is a leader in live tool technology. The formula is simple. Use only the best angular contact high-speed bearings available. Add to this an exacting tolerances for all ground shafts, gears and bearing pocket features. Next, develop a sealed system that **will not** allow any contamination from chips or coolant.

Top this all off with a superior design and you end up with a live tool that is more rigid, faster and will last longer. **We back this up with a 2-Year factory warranty.**

Our Live Tool Warranty

Our tooling will give years of service in the most demanding applications. The superior design and rugged construction has proven this over the last 12 years. The reliability of our tools allows us to provide a 2-year factory warranty, for non-wear components.

MD Tooling will repair any defective tool holders for a period of 2 years from the date of purchase.

Product Range

We have the largest range of live tooling available for most major machine tool manufactures.

Our available products include an extensive line of standard live tooling as well as specialty tool holders such as 0-180 adjustable angle tool holders, gear hobbors, and even worm gear generators. Our product range includes geared up holders to 60,000 RPM and are engineered for 1,000 PSI coolant through.

We are an industry leader in providing complete tooling solutions with hundreds of static tool options as well.

Technical Support

Here at MD Tooling we have a full technical support department with over 35 years of CNC experience.

Our highly qualified staff can help with part processing, tooling up a job from a blue print and even assist with part programming. Applications Engineers are always available by phone to answer any questions you may have about our tooling or any other CNC related issue.

Stock and Replenishment

MD Tooling maintains an extensive inventory of tooling in our warehouse in Michigan. Our current "fill" rate on orders is 93% from our stock in Michigan for same day shipping.

Should you require a non-stock item, our manufacturer, M.T. Marchetti also maintains a large inventory in Italy. Tooling can be obtained in as little as 3-5 business days.

Shipping

MD Tooling realizes that when you need tooling, often you can't wait until the next day. We process orders and ship from available stock right up until 4PM EST to make certain we get your tooling solutions to you as quickly as possible.

We regularly ship throughout the day via UPS, FedEx or any other carrier that a customer requests.



10139 Bergin Road
Howell, MI 48843
Phone: (810) 632-4446
Fax: (810) 632-4467
Email: info@mdtooling.com
Web: www.mdtooling.com

- Fast, Friendly, Reliable Service!
- Quality tooling at highly competitive pricing.
- 2-Year Warranty on all live tools.
- Extensive inventory. We currently ship over 93% of all orders same day.
- In-house repair services available.
- If a warranty tool needs to be returned for inspection, service or repair, loaner tools are available to keep your machine tool production up and running.
- More specialty tool holders than any other manufacturer.
- Custom tool holders available.
- All available tooling may not be shown in this catalog. If you can't find the holder you're looking for, please contact our office for assistance.



Table of Contents

Categorized Listing

DRIVEN	1	EX708/710/910 - NEX108/110/908/910 - LA200/250Y - LA250YS 15ST.	
TCY160/200	1	FX-800 - MX-800 - EX2000Y	14
RADIAL DRIVEN TOOL	1	AXIAL SINGLE SIDE TWIN HEAD DRIVEN TOOL IN Y FOR SUBSPINDLE	14
RADIAL GEARED-UP 1:2 DRIVEN TOOL RE-DIRECTED IN Z BY 50mm	1	EX308/310/508/510/708/710/910 - TC350MC - TT350MC	
AXIAL DRIVEN TOOL	2	NEX108/110/908/910 - LA200/250 M/Y - LA250YS 15ST. -	
AXIAL OPPOSITE FACE DRIVEN TOOL	2	FX-800 - MX-800 - VTL450M - EX2000M/Y - LX2500M	15
(0-180) ADJUSTABLE ANGLE DRIVEN TOOL H=70mm	3	(0-180) ADJUSTABLE ANGLE DRIVEN TOOL H=65mm	15
(0-180) ADJUSTABLE ANGLE DRIVEN TOOL WITH DIGITAL DISPLAY H=70mm	3	(0-180) ADJUSTABLE ANGLE DRIVEN TOOL WITH DIGITAL DISPLAY H=65mm	15
(0-180) ADJUSTABLE ANGLE DRIVEN TOOL GEARED-UP 1:2 H=70mm	4	EX308/310/508/510/708/710/910 - TC350MC - TT350MC	
(0-180) ADJUSTABLE ANGLE DRIVEN TOOL GEARED-UP 1:2 WITH DIGITAL DISPLAY H=70mm	4	NEX108/110/908/910 - LA200/250 M/Y - LA250YS 15ST. -	
		FX-800 - VTL450M - EX2000M/Y - LX2500M	16
		BROACHING/SLOTING DRIVEN TOOL 50mm STROKE H=90mm	16
		BROACHING/SLOTING DRIVEN TOOL 25mm STROKE H=90mm	16
STATIC	5	STATIC	17
TCY160/200	5	EX308/310/508/510/708/710/910 - TC350MC - TT350MC	
RADIAL SINGLE STATIC TOOL	5	NEX108/110/908/910 - LA200/250 M/Y - LA250YS 15ST. -	
RADIAL DOUBLE STATIC TOOL	5	FX-800 - MX-800 - VTL450M - EX2000M/Y - LX2500M	17
RADIAL BLADE HOLDER WITH BLADE KIT	5	RADIAL SINGLE STATIC TOOL H=75mm	17
AXIAL SINGLE STATIC TOOL	6	EX708/710/910 - NEX108/110/908/910 - LA200/250Y - LA250YS 15ST.	
AXIAL SINGLE BORING BAR HOLDER H=90mm	6	FX-800 - EX2000Y	17
		RADIAL SINGLE SIDE TWIN STATIC TOOL	17
		EX308/310/508/510/708/710/910 - TC350MC - TT350MC	
		NEX108/110/908/910 - LA200/250 M/Y - LA250YS 15ST. -	
		FX-800 - MX-800 - VTL450M - EX2000M/Y - LX2500M	18
		AXIAL SINGLE STATIC TOOL	18
		EX308/310 - NEX108/110 - LA200/250 M/Y - LA250YS 15ST.	18
		AXIAL DOUBLE BORING BAR HOLDER	18
		EX308/310/508/510/708/710/910 - TC350MC - TT350MC	
		NEX108/110/908/910 - LA200/250 M/Y - LA250YS 15ST. -	
		FX-800 - MX-800 - VTL450M - EX2000M/Y - LX2500M	19
		RADIAL SINGLE STATIC TOOL CAPTO C4	19
		EX308/310/508/510/708/710/910 - TC350MC - TT350MC	
		NEX108/110/908/910 - LA200/250 M/Y - LA250YS 15ST. -	
		FX-800 - VTL450M - EX2000M/Y - LX2500M	19
		AXIAL SINGLE STATIC TOOL CAPTO C4	19
DRIVEN	7	DRIVEN	20
EX308/310/508/510/708/710/910 - TC350MC - TT350MC		TMM200/250 - TNR200	20
NEX108/110/908/910 - LA200/250 M/Y - LA250YS 15ST. -		RADIAL DRIVEN TOOL VDI40	20
FX-800 - MX-800 - VTL450M - EX2000M/Y - LX2500M	7	AXIAL DRIVEN TOOL FOR MAIN SPINDLE VDI40	21
RADIAL DRIVEN TOOL	7	QUICK CHANGE AXIAL MTSK DRIVEN TOOL FOR MAIN SPINDLE VDI40	21
EX308/310/508/510/708/710/910 - TC350MC - TT350MC		AXIAL DRIVEN TOOL FOR MAIN SPINDLE VDI40	22
NEX108/110/908/910 - LA200/250 M/Y - LA250YS 15ST. -		QUICK CHANGE AXIAL MTSK DRIVEN TOOL FOR MAIN SPINDLE VDI40	23
FX-800 - VTL450M - EX2000M/Y - LX2500M	7	AXIAL DRIVEN TOOL FOR SUBSPINDLE VDI40	23
RADIAL GEARED-UP 1:2 DRIVEN TOOL REDIRECTED IN Z BY 70mm	7	QUICK CHANGE AXIAL MTSK DRIVEN TOOL FOR SUBSPINDLE VDI40	24
EX308/310/508/510/708/710/910 - TT350MC - NEX908/910 - LA250YS		AXIAL DRIVEN TOOL FOR SUBSPINDLE VDI40	25
15ST. - FX-800 - MX-800 - EX2000M/Y	8	QUICK CHANGE AXIAL MTSK DRIVEN TOOL FOR SUBSPINDLE VDI40	26
RADIAL GEARED-UP 1:2 DRIVEN TOOL FOR SUBSPINDLE REDIRECTED IN Z BY 70mm	8	AXIAL GEARED-UP 1:3 DRIVEN TOOL FOR MAIN SPINDLE VDI40 H=90mm	27
EX708/710/910 - NEX108/110/908/910 - LA200/250Y - LA250YS 15ST.		AXIAL GEARED-UP 1:3 DRIVEN TOOL FOR SUBSPINDLE VDI40 H=90mm	27
FX-800 - MX-800 - EX2000Y	8	DRIVEN GEAR HOBBER VDI40	28
RADIAL SINGLE SIDE TWIN HEAD DRIVEN TOOL IN Y	8	NEX315/715 - LS800M - VTL750M - LA350M - LA250YS 12ST.	29
EX308/310/508/510/708/710/910 - TC350MC - TT350MC		RADIAL DRIVEN TOOL	29
NEX108/110/908/910 - LA200/250 M/Y - LA250YS 15ST. -		RADIAL DRIVEN TOOL HIGH PRESSURE	29
FX-800 - VTL450M - EX2000M/Y - LX2500M	9	RADIAL INVERTED DRIVEN TOOL REDIRECTED IN Z BY 180mm	30
AXIAL DRIVEN TOOL FOR MAIN SPINDLE	9	AXIAL DRIVEN TOOL	31
QUICK CHANGE AXIAL MTSK DRIVEN TOOL FOR MAIN SPINDLE	9	(0-180) ADJUSTABLE ANGLE DRIVEN TOOL H=70mm	31
EX308/310/508/510/708/710/910 - TT350MC - NEX908/910 - LA250YS		REINFORCED DRIVEN GEAR HOBBER	32
15ST. - FX-800 - MX-800 - EX2000M/Y	10	TY2000Y/YS/CS	33
AXIAL DRIVEN TOOL FOR SUBSPINDLE	10	RADIAL DRIVEN TOOL	33
QUICK CHANGE AXIAL MTSK DRIVEN TOOL FOR SUBSPINDLE	10	RADIAL SINGLE SIDE TWIN HEAD DRIVEN TOOL IN Y	33
EX308/310/508/510/708/710/910 - TC350MC - NEX108/110/908/910		AXIAL DRIVEN TOOL	34
LA200/250 M/Y - LA250YS 15ST. - FX-800 - EX2000M/Y	11	AXIAL OPPOSITE FACE DRIVEN TOOL	34
AXIAL REAR-SET DRIVEN TOOL FOR MAIN SPINDLE	11	TS3000/4000/5000 Y/YS 15 ST. - TM4000 12ST.	35
EX308/310/508/510/708/710/910 - TT350MC - NEX908/910 - LA250YS			
15ST. - FX-800 - MX-800 - EX2000M/Y	11		
AXIAL REAR-SET DRIVEN TOOL FOR SUPSPINDLE	11		
EX308/310/508/510/708/710/910 - TC350MC - TT350MC			
NEX108/110/908/910 - LA200/250 M/Y - LA250YS 15ST. -			
FX-800 - VTL450M - EX2000M/Y - LX2500M	12		
AXIAL GEARED-UP 1:2 DRIVEN TOOL FOR MAIN SPINDLE	12		
EX308/310/508/510/708/710/910 - TT350MC - NEX908/910 - LA250YS			
15ST. - FX-800 - MX-800 - EX2000M/Y	12		
AXIAL GEARED-UP 1:2 DRIVEN TOOL FOR SUBSPINDLE	12		
AXIAL OPPOSITE FACE TWIN DRIVEN TOOL	13		
EX708/710/910 - NEX108/110/908/910 - LA200/250Y - LA250YS 15ST.			
FX-800 - EX2000Y	14		
AXIAL SINGLE SIDE TWIN HEAD DRIVEN TOOL IN Y FOR MAIN SPINDLE	14		

Table of Contents

Categorized Listing

RADIAL DRIVEN TOOL	35	0-180° ADJUSTABLE ANGLE DRIVEN TOOL	65
QUICK CHANGE RADIAL MTSK DRIVEN TOOL	35	0-180° ADJUSTABLE ANGLE DRIVEN TOOL WITH DIGITAL DISPLAY	65
RADIAL SINGLE SIDE TWIN HEAD DRIVEN TOOL IN Y	36	0-180° ADJUSTABLE ANGLE DRIVEN TOOL	66
AXIAL DRIVEN TOOL	37	0-180° ADJUSTABLE ANGLE DRIVEN TOOL WITH DIGITAL DISPLAY	66
QUICK CHANGE AXIAL MTSK DRIVEN TOOL	37	0-180° ADJUSTABLE ANGLE DRIVEN TOOL	67
AXIAL OPPOSITE FACE DRIVEN TOOL	38	0-180° ADJUSTABLE ANGLE GEARED-UP 1:2 DRIVEN TOOL	67
AXIAL SINGLE SIDE TWIN HEAD DRIVEN TOOL IN Y	38	0-180° ADJUSTABLE ANGLE GEARED-UP 1:2 DRIVEN TOOL WITH DIGITAL DISPLAY	68
(0-180) ADJUSTABLE ANGLE DRIVEN TOOL	39	DRIVEN GEAR HOBBER	69
(0-180) ADJUSTABLE ANGLE DRIVEN TOOL WITH DIGITAL DISPLAY	39	GEAR HOBBER - HEAVY DUTY TOOL	69
(0-180) ADJUSTABLE ANGLE GEARED-UP 1:2 DRIVEN TOOL	40	LARGE DRIVEN GEAR HOBBER	70
(0-180) ADJUSTABLE ANGLE GEARED-UP 1:2 DRIVEN TOOL WITH DIGITAL DISPLAY	40	QUICK CHANGE AXIAL MTSK DRIVEN TOOL FOR POWER SKIVING	
DRIVEN GEAR HOBBER	41	H=106mm	70
STATIC	42	±45° Y AXIS ADJUSTABLE ANGLE DRIVEN TOOL	71
TS3000/4000/5000 Y/YS 15 ST. - TM4000 12ST.	42	WORM GEAR DRIVEN TOOL	71
RADIAL SINGLE STATIC TOOL	42	BROACHING/SLOTTING DRIVEN TOOL 50mm STROKE H=94mm	72
RADIAL REAR-SET SINGLE STATIC TOOL	42	BROACHING/SLOTTING DRIVEN TOOL 25mm STROKE H=94mm	72
RADIAL SINGLE SIDE TWIN STATIC TOOL	43	STATIC	73
RADIAL DOUBLE STATIC TOOL	43	TS3000/4000/5000 Y/YS 12 ST. (3 KEYS TURRET)	73
RADIAL BLADE HOLDER WITH BLADE KIT	44	RADIAL SINGLE STATIC TOOL	73
RADIAL BLADE HOLDER WITH INTERNAL COOLANT-BLADE KIT NOT INCLUDED	44	RADIAL SINGLE STATIC TOOL	73
AXIAL SINGLE STATIC TOOL	45	RADIAL SINGLE STATIC TOOL	73
AXIAL SINGLE BORING BAR HOLDER H=90mm	45	RADIAL REAR-SET SINGLE STATIC TOOL	74
AXIAL OPPOSITE FACE BORING BAR HOLDER H=90mm	46	RADIAL SINGLE SIDE TWIN STATIC TOOL	74
AXIAL DOUBLE BORING BAR HOLDER	46	RADIAL DOUBLE STATIC TOOL	75
DRIVEN	47	RADIAL DOUBLE SIDE TWIN STATIC TOOL	75
TS3000/4000/5000 Y/YS 12 ST. (3 KEYS TURRET)	47	RADIAL DOUBLE BLADE HOLDER WITH BLADE KIT	76
RADIAL DRIVEN TOOL	47	RADIAL DOUBLE TWIN SIDE BLADE HOLDER WITH BLADE KIT	76
QUICK CHANGE RADIAL MTSK DRIVEN TOOL	48	RADIAL DOUBLE BLADE HOLDER WITH INTERNAL COOLANT- BLADE KIT NOT INCLUDED	76
RADIAL DRIVEN TOOL HIGH PRESSURE	48	AXIAL SINGLE STATIC TOOL	77
QUICK CHANGE RADIAL MTSK DRIVEN TOOL HIGH PRESSURE	49	AXIAL SINGLE STATIC TOOL - LOWER HEIGHT	77
RADIAL REINFORCED MILLING TOOL	49	AXIAL SINGLE BORING BAR HOLDER H=80mm	78
QUICK CHANGE RADIAL MTSK REINFORCED DRIVEN TOOL	50	AXIAL SINGLE BORING BAR HOLDER H=80mm	78
RADIAL DRIVEN TOOL REDIRECTED IN Z BY 45mm	50	AXIAL SINGLE BORING BAR HOLDER 60mm H=110mm	78
QUICK CHANGE RADIAL MTSK DRIVEN TOOL REDIRECTED IN Z BY 45mm	51	AXIAL SINGLE BORING BAR HOLDER 80mm H=110mm	79
RADIAL GEARED-DOWN 2:1 DRIVEN TOOL REDIRECTED IN Z BY 45mm	51	AXIAL SINGLE EXTENDED BORING BAR HOLDER 40mm H=115mm	79
QUICK CHANGE RADIAL MTSK GEARED-DOWN 2:1 DRIVEN TOOL REDIRECTED IN Z BY 45mm	52	AXIAL SINGLE EXTENDED BORING BAR HOLDER H=80mm	79
RADIAL GEARED-UP 1:2 DRIVEN TOOL REDIRECTED IN Z BY 45mm	52	AXIAL 2 + 2 POSITION BORING BAR HOLDER	80
RADIAL GEARED-UP 1:5 DRIVEN TOOL	53	AXIAL 3 + 3 POSITION UPRIGHT BORING BAR HOLDER	80
RADIAL SINGLE SIDE TWIN HEAD DRIVEN TOOL FOR Y-AXIS	54	AXIAL 3 POSITION UPRIGHT REAR SET BORING BAR HOLDER	80
RADIAL SINGLE SIDE TWIN HEAD DRIVEN TOOL FOR Z-AXIS	54	AXIAL 3 + 3 POSITION BORING BAR HOLDER	81
RADIAL 6 HEAD DRIVEN TOOL	55	AXIAL 4 + 4 POSITION BORING BAR HOLDER	81
RADIAL INVERTED DRIVEN TOOL REDIRECTED IN Z	55	AXIAL 8 POSITION BORING BAR HOLDER	81
RADIAL ±25° ADJUSTABLE ANGLE DRIVEN TOOL REDIRECTED BY 50mm	56	TAILSTOCK FOR SUB-SPINDLE	82
AXIAL DRIVEN TOOL	57	CAPTO DRIVEN	83
QUICK CHANGE AXIAL MTSK DRIVEN TOOL	58	TS3000/4000/5000 Y/YS 12 ST. (3 KEYS TURRET)	83
AXIAL REAR-SET DRIVEN TOOL	58	RADIAL DRIVEN TOOL CAPTO	83
AXIAL DRIVEN TOOL	59	AXIAL DRIVEN TOOL CAPTO	84
QUICK CHANGE AXIAL MTSK DRIVEN TOOL	59	AXIAL OPPOSITE FACE TWIN DRIVEN TOOL CAPTO	84
AXIAL GEARED-DOWN 2:1 DRIVEN TOOL	60	CAPTO STATIC	85
AXIAL GEARED-UP 1:2 DRIVEN TOOL	60	TS3000/4000/5000 Y/YS 12 ST. (3 KEYS TURRET)	85
AXIAL MTSK DRIVEN TOOL FOR INTERNAL POLYGON-MAKING H=90mm	61	RADIAL SINGLE STATIC TOOL - CAPTO	85
AXIAL SINGLE SIDE TWIN HEAD DRIVEN TOOL IN Y FOR INTERNAL POLYGON-MAKING H=90mm	61	RADIAL DOUBLE STATIC TOOL - CAPTO	85
AXIAL OPPOSITE FACE TWIN DRIVEN TOOL	62	RADIAL DOUBLE 2+2 UPRIGHT POSITION STATIC TOOL - CAPTO	86
QUICK CHANGE AXIAL MTSK OPPOSITE FACE TWIN DRIVEN TOOL	62	RADIAL DOUBLE 3+3 UPRIGHT POSITION STATIC TOOL - CAPTO	86
AXIAL GEARED-DOWN 2:1 OPPOSITE FACE TWIN DRIVEN TOOL	62	AXIAL SINGLE STATIC TOOL - CAPTO	87
AXIAL GEARED-UP 1:2 OPPOSITE FACE TWIN DRIVEN TOOL	63	AXIAL SINGLE STATIC TOOL - CAPTO C6	87
AXIAL SINGLE SIDE TWIN HEAD DRIVEN TOOL IN Y	64	AXIAL REAR-SET BORING SINGLE STATIC TOOL - CAPTO	88
AXIAL MULTIPLE 4/8 OUTLET HEAD DRIVEN TOOL	64	AXIAL OPPOSITE FACE TWIN STATIC TOOL - CAPTO	88
		DRIVEN	89
		TT-2600CM	89
		RADIAL DRIVEN TOOL REDIRECTED IN Z BY 80mm	89

Table of Contents

Categorized Listing

RADIAL GEARED-DOWN 2:1 DRIVEN TOOL REDIRECTED IN Z BY 80mm	89
RADIAL GEARED-UP 1:4 DRIVEN TOOL REDIRECTED IN Z BY 80mm	90
AXIAL DRIVEN TOOL H=105mm	91
STATIC	92
TT-2600CM	92
RADIAL SINGLE STATIC TOOL	92
AXIAL SINGLE STATIC TOOL	92
AXIAL SINGLE BORING BAR HOLDER H=110mm	93
AXIAL REAR-SET BORING BAR HOLDER H=110mm	93
DRIVEN	94
ACCESSORIES	94
MTSK-40 ER ADAPTORS	94
MTSK-40 MILL ADAPTORS	95
MTSK-50 ER ADAPTORS	96
MTSK-50 MILL ADAPTORS	97
POLYGON MAKING MILL HEAD (3 INSERTS)	98
POLYGON MAKING MILL HEAD (2 INSERTS)	98

DRIVEN

TCY160/200

RADIAL DRIVEN TOOL

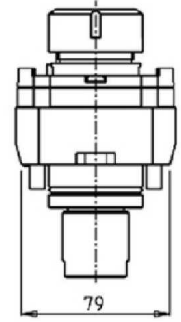
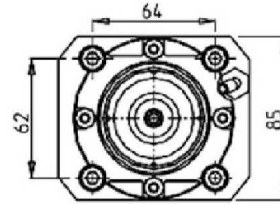
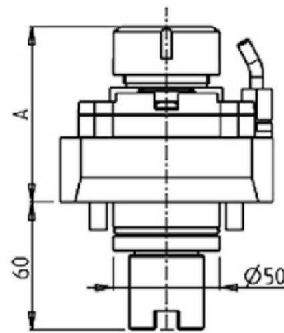
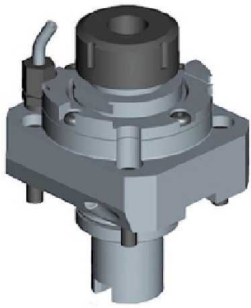

PartNumber	Description	Spindle	I	RPM	Cool Thru	Ext Cool	A
TKW0020132	Radial Driven Tool ER32	ER32	1:1	6000		X	82.16
TKW0020432	Radial Driven Tool ERA32 Cool Thru*	ERA32	1:1	6000	X	X	86.9

* Coolant Thru tools are designed for 1000 psi.
They require 5 Micron Filtration and **CANNOT** be run dry.

RADIAL GEARED-UP 1:2 DRIVEN TOOL RE-DIRECTED IN Z BY 50mm

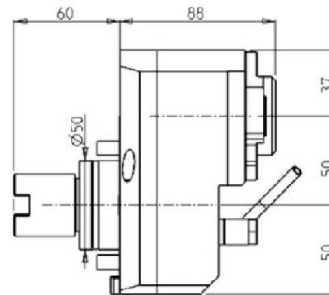
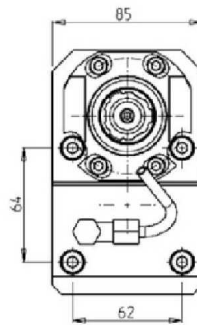

PartNumber	Description	Spindle	I	RPM	Reversible	Cool Thru	Ext Cool
TKW0222125	Radial Geared-up 1:2 Re-directed ERA25	ERA25	1:2	12000	X		X
TKW0222225	Radial Geared-up 1:2 Re-directed ERA25 Cool Thru*	ERA25	1:2	12000	X	X	X

* Coolant Thru tools are designed for 1000 psi.
They require 5 Micron Filtration and **CANNOT** be run dry.

DRIVEN

TCY160/200

AXIAL DRIVEN TOOL

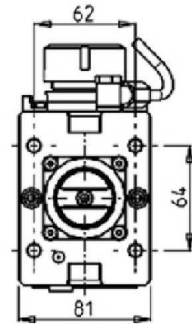
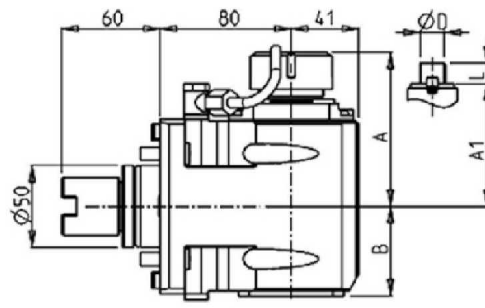

PartNumber	Description	Spindle	Reversible	I	RPM	Cool Thru	Ext Cool	A	A1	B	D	L
TKW0010125	Axial Driven ER25	ER25	X	1:1	6000		X	91.16		57		
TKW0010225	Axial Driven ER25 Cool Thru*	ER25	X	1:1	6000	X	X	91.16		67		
TKW0010325	Axial Driven ERA25	ERA25	X	1:1	6000		X	65		57		
TKW0010425	Axial Driven ERA25 Cool Thru*	ERA25	X	1:1	6000	X	X	65		67		
TKW0010132	Axial Driven ER32	ER32	X	1:1	6000		X	93.66		57		
TKW0010232	Axial Driven ER32 Cool Thru*	ER32	X	1:1	6000	X	X	93.66		67		
TKW0010140	Axial Driven ER40	ER40	X	1:1	6000		X	98.16		57		
TKW0010240	Axial Driven ER40 Cool Thru*	ER40	X	1:1	6000	X	X	98.16		67		
TKW0010516	Axial Mill Head 16x17	16X17	X	1:1	6000		X		67.5	16	17	
TKW0010522	Axial Mill Head 22x19	22X19	X	1:1	6000		X		67.5	22	19	
TKW0010527	Axial Mill Head 27x21	27X21	X	1:1	6000		X		70	27	21	

* Coolant Thru tools are designed for 1000 psi.
They require 5 Micron Filtration and **CANNOT** be run dry.

AXIAL OPPOSITE FACE DRIVEN TOOL

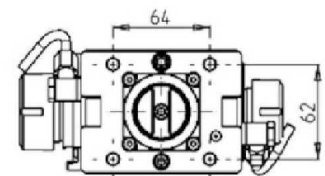
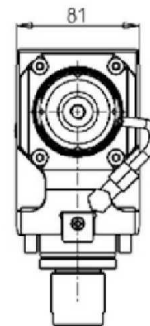
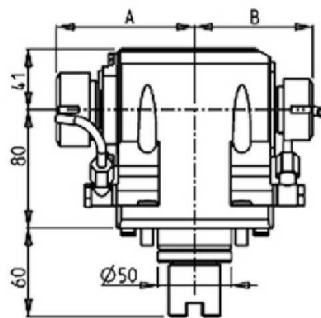

PartNumber	Description	Spindle	Reversible	I	RPM	Ext Cool	A	B
TKW0033225	Axial Opposite Face ER32+ER25	ER32+ER25	X	1:1	6000	X	93.66	80.16
TKW0032520	Axial Opposite Face ERA25+ERA20	ERA25+ERA20	X	1:1	6000	X	65	55.5

DRIVEN

TCY160/200

(0-180) ADJUSTABLE ANGLE DRIVEN TOOL H=70mm

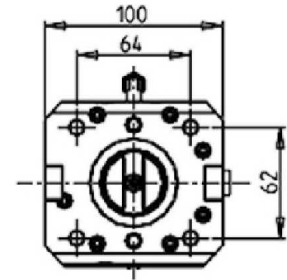
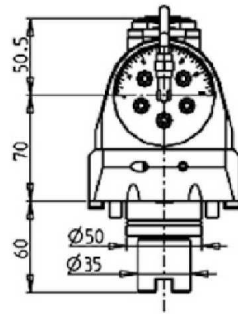
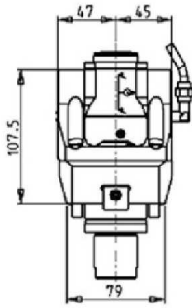

PartNumber	Description	Spindle	I	RPM	Cool Thru	Ext Cool
TKW0500120	(0-180) Adj. Angle ERA20	ERA20	1:1	6000		X
TKW0500220	(0-180) Adj. Angle ERA20 Cool Thru*	ERA20	1:1	6000	X	X

* Coolant Thru tools are designed for 1000 psi. They require 5 Micron Filtration and **CANNOT** be run dry.

Note :

Wrenches are provided with the purchase of Specialty Toolholders

(0-180) ADJUSTABLE ANGLE DRIVEN TOOL WITH DIGITAL DISPLAY H=70mm

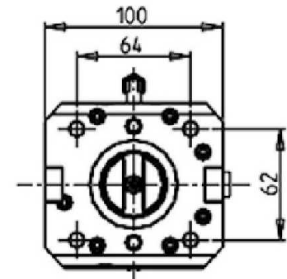
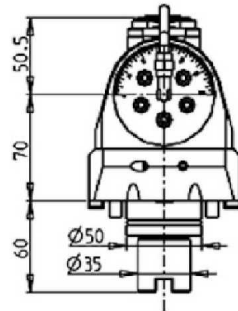
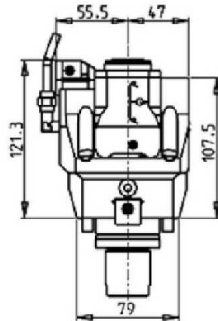
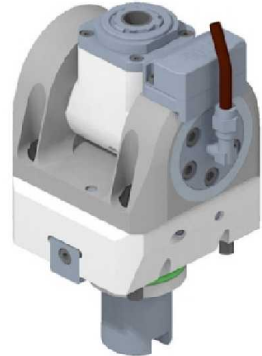

PartNumber	Description	Spindle	I	RPM	Cool Thru	Ext Cool
TKW0505120	(0-180) Adj. Angle ERA20 with Digital Display	ERA20	1:1	6000		X
TKW0505220	(0-180) Adj. Angle ERA20 with Digital Display Cool Thru*	ERA20	1:1	6000	X	X

* Coolant Thru tools are designed for 1000 psi. They require 5 Micron Filtration and **CANNOT** be run dry.

Note :

Wrenches are provided with the purchase of Specialty Toolholders

DRIVEN

TCY160/200

(0-180) ADJUSTABLE ANGLE DRIVEN TOOL GEARED-UP 1:2 H=70mm

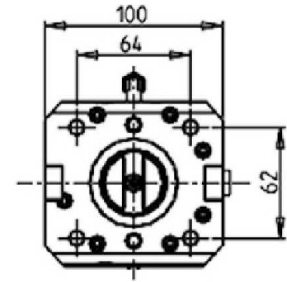
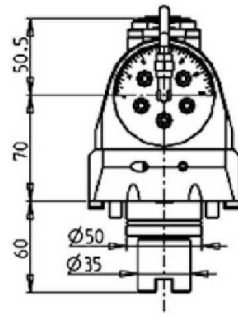
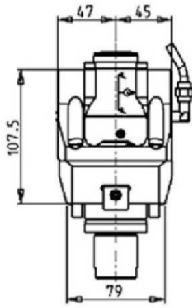
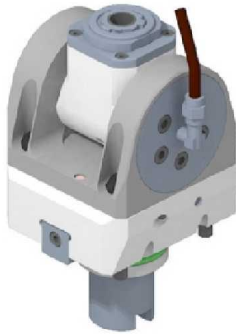

PartNumber	Description	Spindle	I	RPM	Cool Thru	Ext Cool
TKW0500316	(0-180) Adj. Angle Geared-Up 1:2 ERA16	ERA16	1:2	12000		X
TKW0500416	(0-180) Adj. Angle Geared-Up 1:2 ERA16 Cool Thru*	ERA16	1:2	12000	X	X

* Coolant Thru tools are designed for 1000 psi.
They require 5 Micron Filtration and **CANNOT** be run dry.

Note :

Wrenches are provided with the purchase of Specialty Toolholders

(0-180) ADJUSTABLE ANGLE DRIVEN TOOL GEARED-UP 1:2 WITH DIGITAL DISPLAY H=70mm

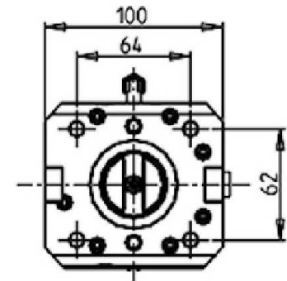
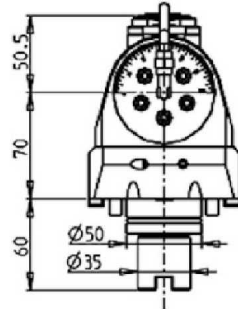
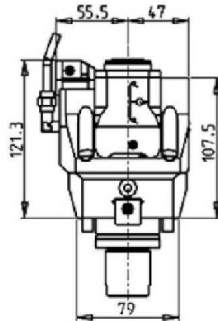

PartNumber	Description	Spindle	I	RPM	Cool Thru	Ext Cool
TKW0505316	(0-180) Adj. Angle Geared-Up 1:2 ERA16 with Digital Display	ERA16	1:2	12000		X
TKW0505416	(0-180) Adj. Angle Geared-Up 1:2 ERA16 with Digital Display Cool Thru*	ERA16	1:2	12000	X	X

* Coolant Thru tools are designed for 1000 psi.
They require 5 Micron Filtration and **CANNOT** be run dry.

Note :

Wrenches are provided with the purchase of Specialty Toolholders

STATIC

TCY160/200

RADIAL SINGLE STATIC TOOL

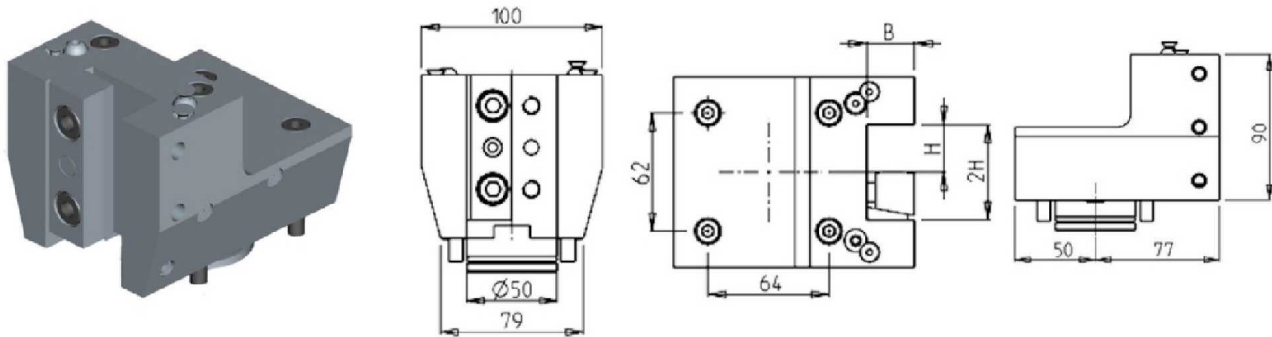

PartNumber	Description	Takisawa Code	# of Tools	Reversible	Dimensions	B	H
TKW0042500	Radial Single Static Tool 25mm	XL2207_001	1/2	X	mm	25	25

RADIAL DOUBLE STATIC TOOL

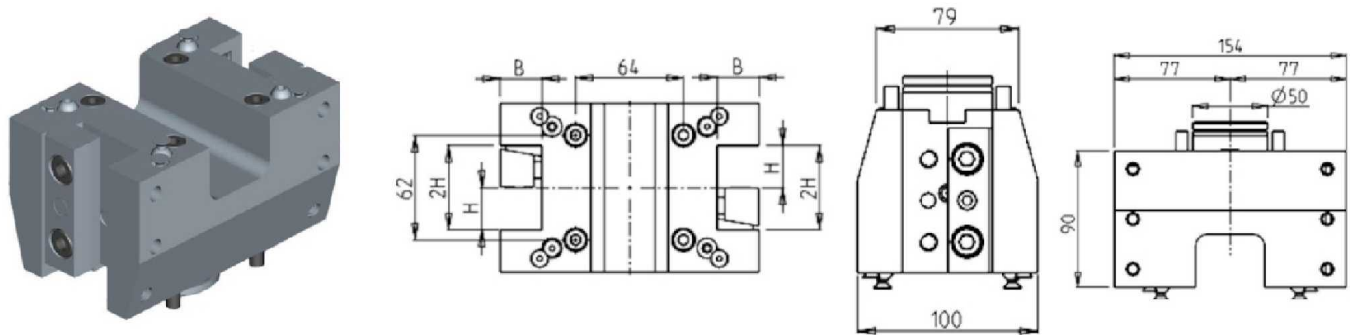

PartNumber	Description	Takisawa Code	# of Tools	Reversible	Dimensions	B	H
TKW0082500	Radial Double Static Tool 25mm	XL22030_001	2/4	X	mm	25	25

RADIAL BLADE HOLDER WITH BLADE KIT

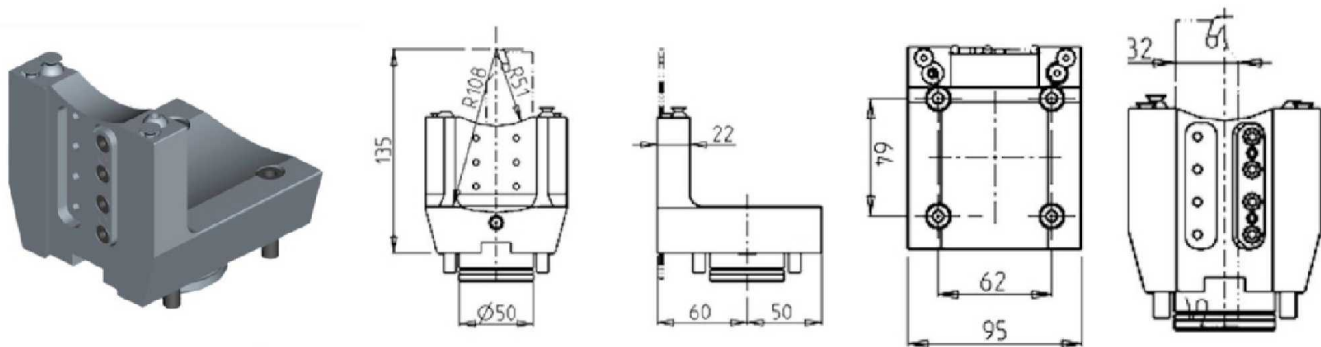

PartNumber	Description	Takisawa Code	# of Tools	Reversible	Ext Cool
TKW0070232	Radial Blade Holder with Blade Kit	XL22037_001	1	X	X
BLADEKIT	Blade Kit: 1 Blade, 10 Inserts				

STATIC

TCY160/200

AXIAL SINGLE STATIC TOOL

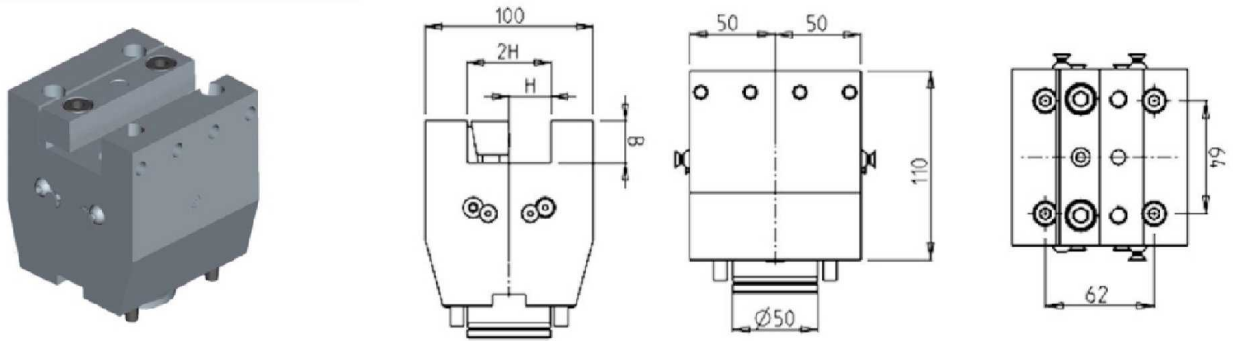

PartNumber	Description	Takisawa Code	# of Tools	Reversible	Dimensions	B	H
TKW0052500	Axial Single Static Tool 25mm	XL22029_001	1/2	X	mm	25	25

AXIAL SINGLE BORING BAR HOLDER H=90mm

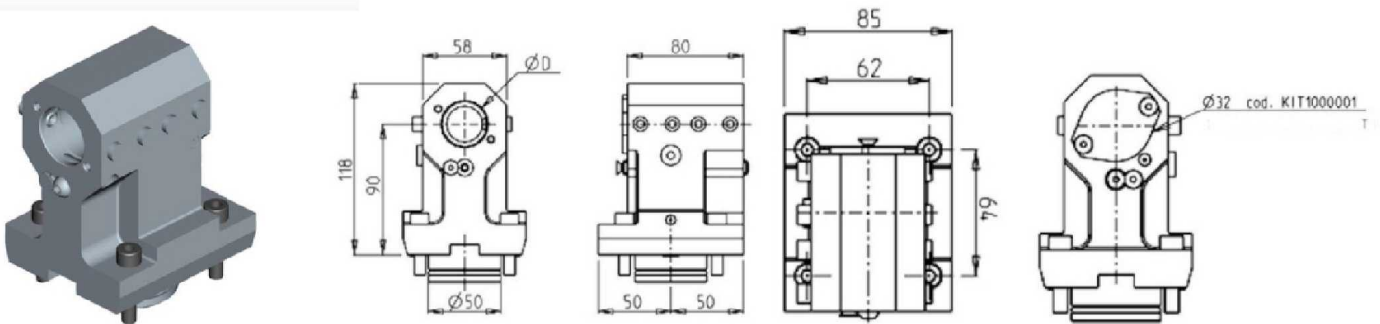

PartNumber	Description	# of Tools	Cool Thru	Ext Cool	Dimensions	D
TKW0063200	Axial Single BBH 32mm	1	X	X	mm	32
KIT1000001	Plug for 32mm BBH to Make Cool Thru					

DRIVEN

EX308/310/508/510/708/710/910 - TC350MC - TT350MC - NEX108/110/908/910 - LA200/250 M/Y - LA250YS 15ST. - FX-800 - MX-800 - VTL450M - EX2000M/Y - LX2500M

RADIAL DRIVEN TOOL

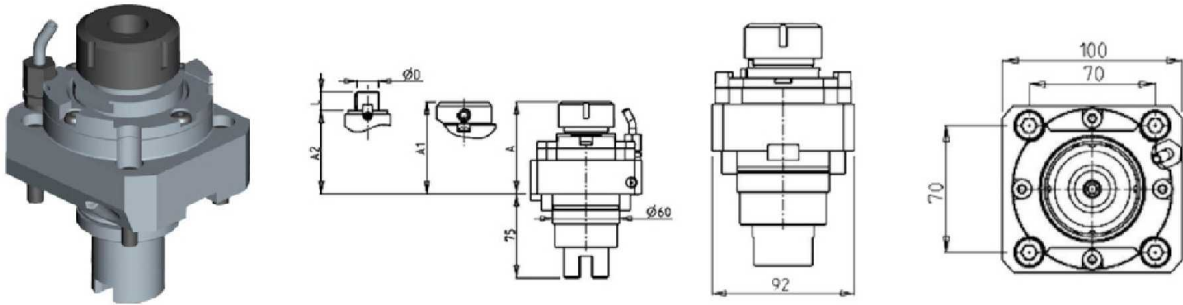

PartNumber	Description	Spindle	I	RPM	Cool Thru	Ext Cool	A	A1	A2	D	L
TKW0120132	Radial Driven Tool ER32	ER32	1:1	6000		X	82.16				
TKW0120232	Radial Driven Tool ER32 Cool Thru*	ER32	1:1	6000	X	X	92.66				
TKW0120825	Radial Driven Tool Weldon 25 Cool Thru*	Weldon 25	1:1	6000	X	X		86			
TKW0120522	Radial Mill Head $\varnothing 22 \times 19$	$\varnothing 22 \times 19$	1:1	6000		X				57.5	22 19

*Coolant Thru tools are designed for 400 psi MAX.
They require 5 Micron Filtration and **CANNOT** be run dry.

EX308/310/508/510/708/710/910 - TC350MC - TT350MC - NEX108/110/908/910 - LA200/250 M/Y - LA250YS 15ST. - FX-800 - VTL450M - EX2000M/Y - LX2500M

RADIAL GEARED-UP 1:2 DRIVEN TOOL REDIRECTED IN Z BY 70mm

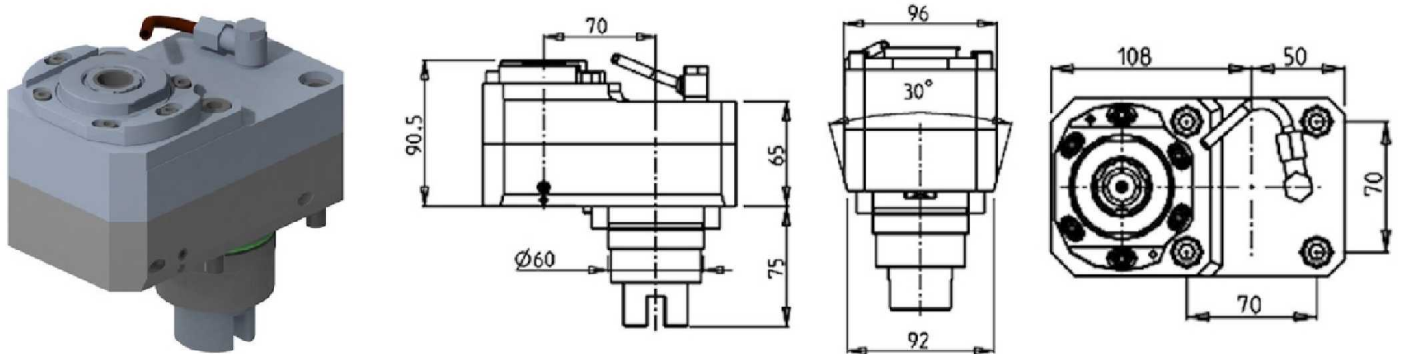

PartNumber	Description	Spindle	I	MAX RPM	Cool Thru	Ext Cool
TKW0430325	Radial Geared-Up 1:2 Redirected ERA25	ERA25	1:2	12000		X
TKW0430425	Radial Geared-Up 1:2 Redirected ERA25 Cool Thru*	ERA25	1:2	12000	X	X

* Coolant Thru tools are designed for 1000 psi.
They require 5 Micron Filtration and **CANNOT** be run dry.

DRIVEN

EX308/310/508/510/708/710/910 - TT350MC - NEX908/910 - LA250YS 15ST. - FX-800 - MX-800 - EX2000M/Y

RADIAL GEARED-UP 1:2 DRIVEN TOOL FOR SUBSPINDLE REDIRECTED IN Z BY 70mm

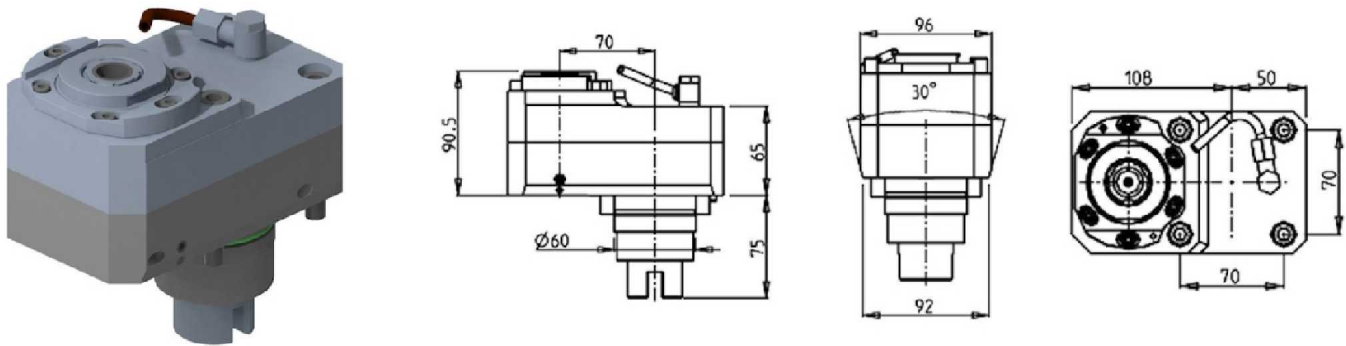

PartNumber	Description	Spindle	I	MAX RPM	Cool Thru	Ext Cool
TKW0430525	Radial Geared-Up 1:2 Redirected ERA25 for Subspindle	ERA25	1:2	12000		X
TKW0430625	Radial Geared-Up 1:2 Redirected ERA25 for Subspindle Cool Thru*	ERA25	1:2	12000	X	X

* Coolant Thru tools are designed for 1000 psi.
They require 5 Micron Filtration and **CANNOT** be run dry.

EX708/710/910 - NEX108/110/908/910 - LA200/250Y - LA250YS 15ST. - FX-800 - MX-800 - EX2000Y

RADIAL SINGLE SIDE TWIN HEAD DRIVEN TOOL IN Y

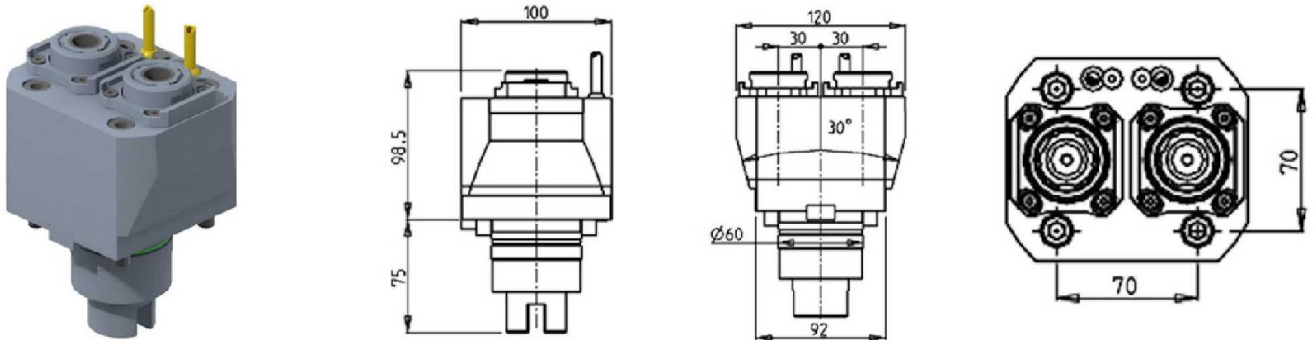

PartNumber	Description	Spindle	I	RPM	Ext Cool
TKW0730325	Radial Single Side Twin ERA25	ERA25	1:1	6000	X

DRIVEN

EX308/310/508/510/708/710/910 - TC350MC - TT350MC - NEX108/110/908/910 - LA200/250 M/Y - LA250YS 15ST. - FX-800 - VTL450M - EX2000M/Y - LX2500M

AXIAL DRIVEN TOOL FOR MAIN SPINDLE

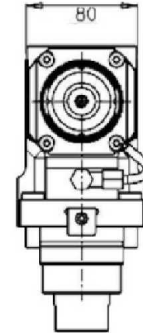
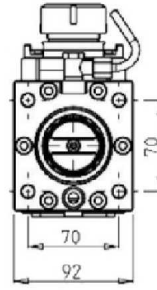
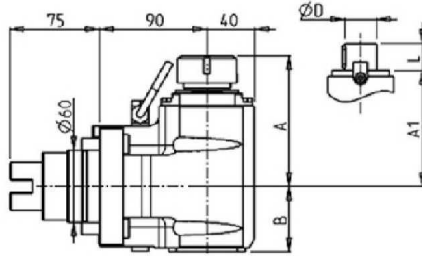

PartNumber	Description	Spindle	I	RPM	Cool Thru	Ext Cool	A	A1	D	L	B
TKW0110132	Axial Driven Tool ER32	ER32	1:1	6000		X	108.7				54.5
TKW0110232	Axial Driven Tool ER32 Cool Thru*	ER32	1:1	6000	X	X	108.7				67
TKW0110527	Axial Mill Head $\phi 27 \times 21$	$\phi 27 \times 21$	1:1	6000		X		85	27	21	54.5

* Coolant Thru tools are designed for 1000 psi.
They require 5 Micron Filtration and **CANNOT** be run dry.

QUICK CHANGE AXIAL MTSK DRIVEN TOOL FOR MAIN SPINDLE

Please see Accessories for MTSK Clamping Units

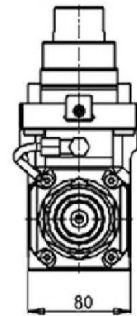
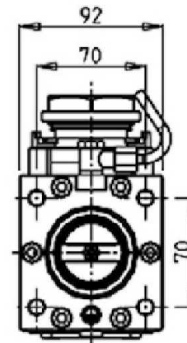
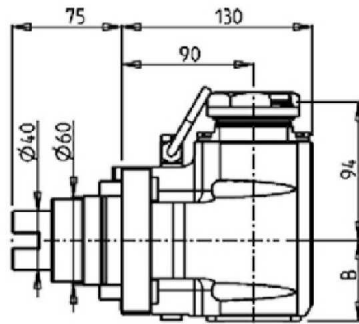

PartNumber	Description	Spindle	I	RPM	Cool Thru	Ext Cool	B
TKW0420150	Axial MTSK-50 Driven Tool	MTSK-50	1:1	6000		X	54.5
TKW0420250	Axial MTSK-50 Driven Tool Cool Thru*	MTSK-50	1:1	6000	X	X	67

* Coolant Thru tools are designed for 1000 psi.
They require 5 Micron Filtration and **CANNOT** be run dry.

DRIVEN

EX308/310/508/510/708/710/910 - TT350MC - NEX908/910 - LA250YS 15ST. - FX-800 - MX-800 - EX2000M/Y

AXIAL DRIVEN TOOL FOR SUBSPINDLE

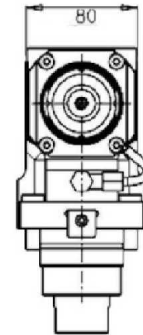
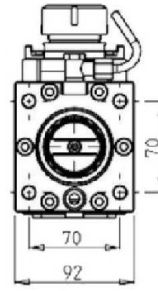
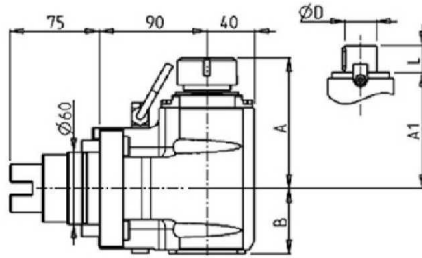

PartNumber	Description	Spindle	I	RPM	Cool Thru	Ext Cool	A	A1	D	L	B
TKW0110332	Axial Driven Tool ER32	ER32	1:1	6000		X	108.7				54.5
TKW0110432	Axial Driven Tool ER32 Cool Thru*	ER32	1:1	6000	X	X	108.7				67
TKW0111527	Axial Mill Head $\phi 27 \times 21$	$\phi 27 \times 21$	1:1	6000		X		85	27	21	54.5

* Coolant Thru tools are designed for 1000 psi.
They require 5 Micron Filtration and **CANNOT** be run dry.

QUICK CHANGE AXIAL MTSK DRIVEN TOOL FOR SUBSPINDLE

Please see Accessories for MTSK Clamping Units

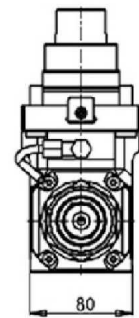
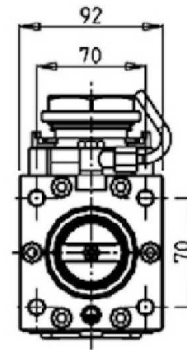
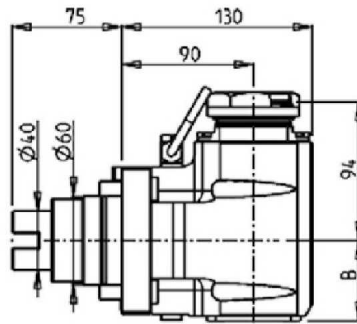

PartNumber	Description	Spindle	I	RPM	Cool Thru	Ext Cool	B
TKW0420350	Axial MTSK-50 Driven Tool	MTSK-50	1:1	6000		X	54.5
TKW0420450	Axial MTSK-50 Driven Tool Cool Thru*	MTSK-50	1:1	6000	X	X	67

* Coolant Thru tools are designed for 1000 psi.
They require 5 Micron Filtration and **CANNOT** be run dry.

DRIVEN

EX308/310/508/510/708/710/910 - TC350MC - NEX108/110/908/910 - LA200/250 M/Y - LA250YS 15ST. - FX-800 - EX2000M/Y

AXIAL REAR-SET DRIVEN TOOL FOR MAIN SPINDLE

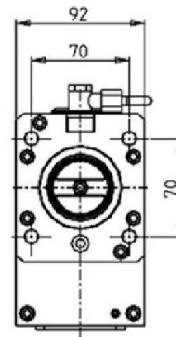
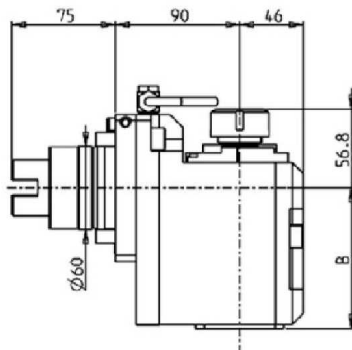

PartNumber	Description	Spindle	I	RPM	Cool Thru	Ext Cool	B
TKW0740125	Axial Rear-Set ER25	ER25	1:1	6000		X	101.4
TKW0740225	Axial Rear-Set ER25 Cool Thru*	ER25	1:1	6000	X	X	113.9

* Coolant Thru tools are designed for 1000 psi.
They require 5 Micron Filtration and **CANNOT** be run dry.

EX308/310/508/510/708/710/910 - TT350MC - NEX908/910 - LA250YS 15ST. - FX-800 - MX-800 - EX2000M/Y

AXIAL REAR-SET DRIVEN TOOL FOR SUPSPINDLE

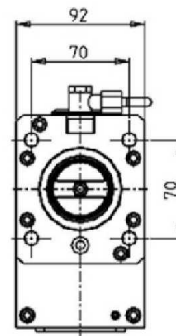
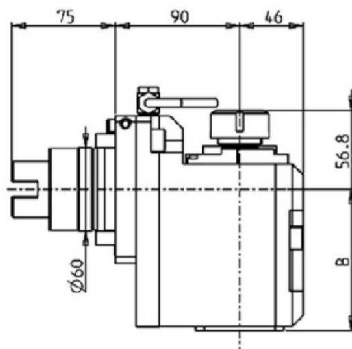
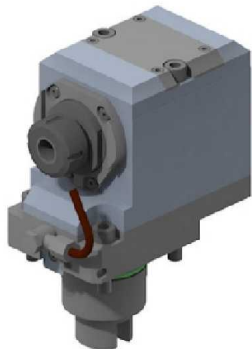

PartNumber	Description	Spindle	I	RPM	Cool Thru	Ext Cool	B
TKW0741125	Axial Rear-Set ER25	ER25	1:1	6000		X	101.4
TKW0741225	Axial Rear-Set ER25 Cool Thru*	ER25	1:1	6000	X	X	113.9

* Coolant Thru tools are designed for 1000 psi.
They require 5 Micron Filtration and **CANNOT** be run dry.

DRIVEN

EX308/310/508/510/708/710/910 - TC350MC - TT350MC - NEX108/110/908/910 - LA200/250 M/Y - LA250YS 15ST. - FX-800 - VTL450M - EX2000M/Y - LX2500M

AXIAL GEARED-UP 1:2 DRIVEN TOOL FOR MAIN SPINDLE

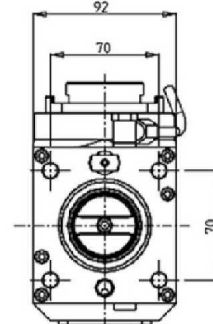
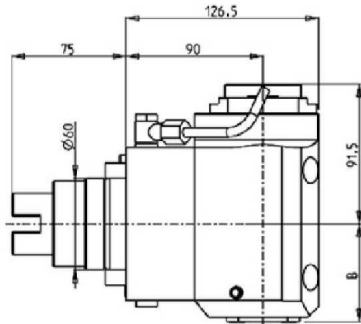

PartNumber	Description	Spindle	I	RPM	Cool Thru	Ext Cool	B
TKW0440325	Axial Geared-Up 1:2 ERA25	ERA25	1:2	12000		X	64
TKW0440425	Axial Geared-Up 1:2 ERA25 Cool Thru*	ERA25	1:2	12000	X	X	74

* Coolant Thru tools are designed for 1000 psi.
They require 5 Micron Filtration and **CANNOT** be run dry.

EX308/310/508/510/708/710/910 - TT350MC - NEX908/910 - LA250YS 15ST. - FX-800 - MX-800 - EX2000M/Y

AXIAL GEARED-UP 1:2 DRIVEN TOOL FOR SUBSPINDLE

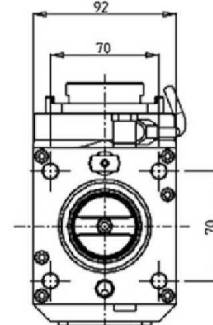
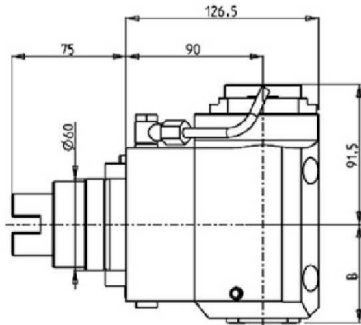

PartNumber	Description	Spindle	I	RPM	Cool Thru	Ext Cool	B
TKW0440525	Axial Geared-Up 1:2 ERA25	ERA25	1:2	12000		X	64
TKW0440625	Axial Geared-Up 1:2 ERA25 Cool Thru*	ERA25	1:2	12000	X	X	74

* Coolant Thru tools are designed for 1000 psi.
They require 5 Micron Filtration and **CANNOT** be run dry.

DRIVEN

EX308/310/508/510/708/710/910 - TT350MC - NEX908/910 - LA250YS 15ST. - FX-800 - MX-800 - EX2000M/Y

AXIAL OPPOSITE FACE TWIN DRIVEN TOOL

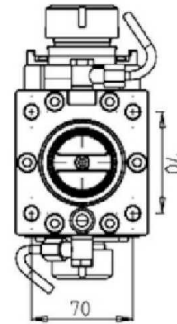
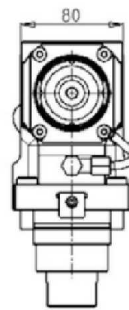
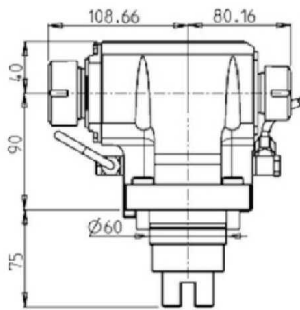

PartNumber	Description	Spindle	I	RPM	Ext Cool
TKW0130132	Axial Opposite Face ER32+ER25	ER32+ER25	1:1	6000	X

DRIVEN

EX708/710/910 - NEX108/110/908/910 - LA200/250Y - LA250YS 15ST. - FX-800 - EX2000Y

AXIAL SINGLE SIDE TWIN HEAD DRIVEN TOOL IN Y FOR MAIN SPINDLE

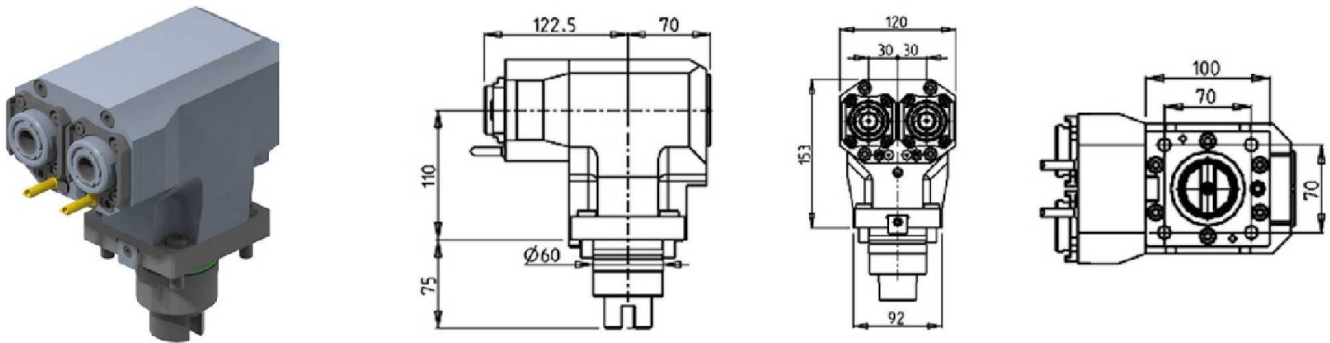

PartNumber	Description	Spindle	I	RPM	Ext Cool
TKW0750325	Axial Single Side Twin ERA25	ERA25	1:1	6000	X

EX708/710/910 - NEX108/110/908/910 - LA200/250Y - LA250YS 15ST. - FX-800 - MX-800 - EX2000Y

AXIAL SINGLE SIDE TWIN HEAD DRIVEN TOOL IN Y FOR SUBSPINDLE

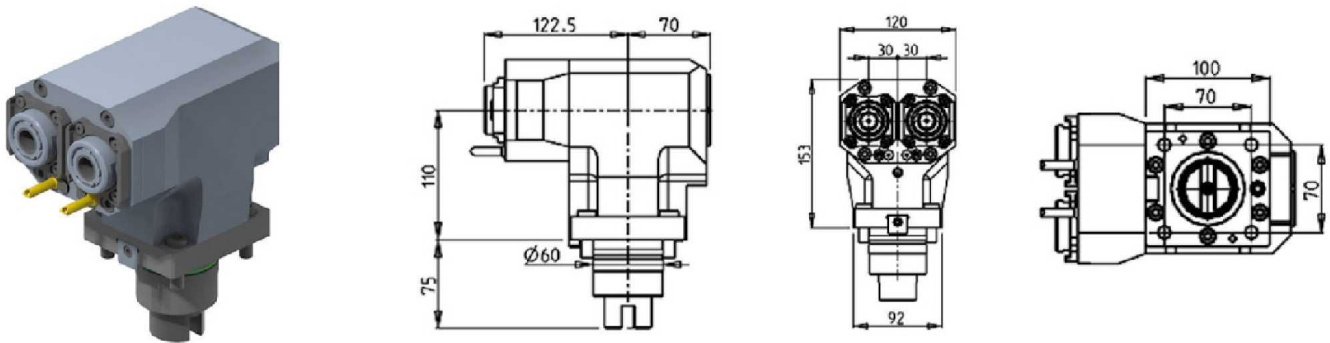

PartNumber	Description	Spindle	I	RPM	Ext Cool
TKW0751325	Axial Single Side Twin ERA25	ERA25	1:1	6000	X

DRIVEN

EX308/310/508/510/708/710/910 - TC350MC - TT350MC - NEX108/110/908/910 - LA200/250 M/Y - LA250YS 15ST. - FX-800 - MX-800 - VTL450M - EX2000M/Y - LX2500M

(0-180) ADJUSTABLE ANGLE DRIVEN TOOL H=65mm

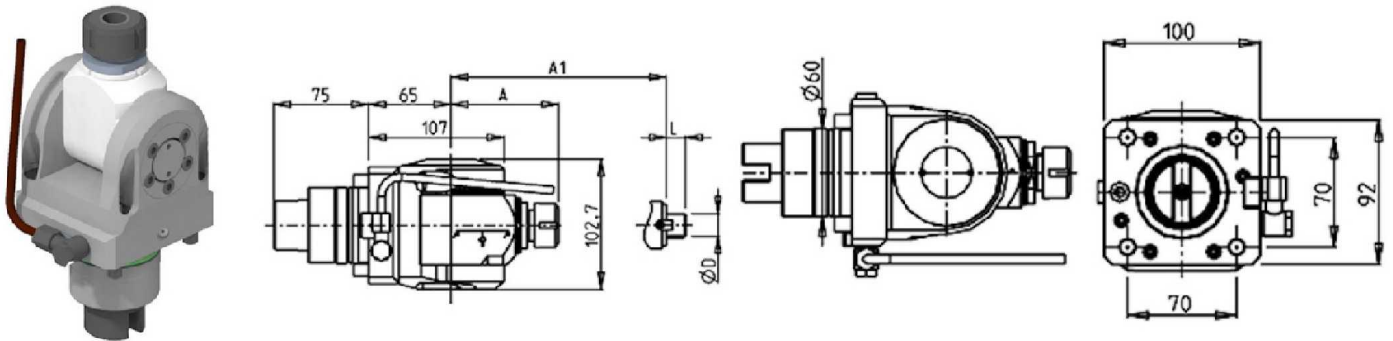

PartNumber	Description	Spindle	I	RPM	Reversible	Ext Cool	A	A1	D	L
TKW0710120	(0-180) Adj. Angle ER20	ER20	1:1	6000	X	X	85.16			
TKW0710125	(0-180) Adj. Angle ER25	ER25	1:1	6000	X	X	86.16			
TKW0710519	(0-180) Adj. Angle 3/4"x3/4"	3/4"x3/4"	1:1	6000	X	X	65	3/4"	3/4"	
TKW0710516	(0-180) Adj. Angle Ø16x17	Ø16x17	1:1	6000	X	X	65	16	17	
TKW0710522	(0-180) Adj. Angle Ø22x19	Ø22x19	1:1	6000	X	X	66	22	19	

Note : Wrenches are provided with the purchase of Specialty Toolholders

(0-180) ADJUSTABLE ANGLE DRIVEN TOOL WITH DIGITAL DISPLAY H=65mm

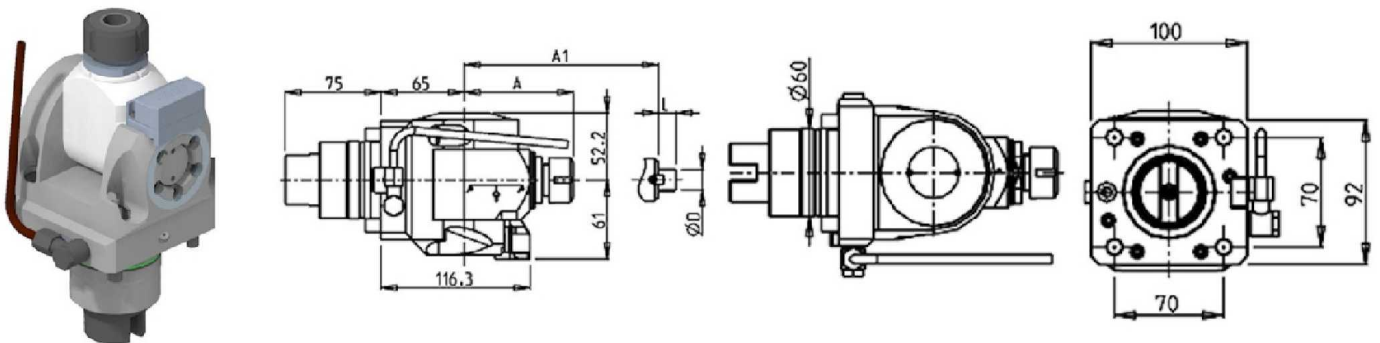

PartNumber	Description	Spindle	I	RPM	Reversible	Ext Cool	A	A1	D	L
TKW0720120	(0-180) Adj. Angle ER20 with Digital Display	ER20	1:1	6000	X	X	85.16			
TKW0720125	(0-180) Adj. Angle ER25 with Digital Display	ER25	1:1	6000	X	X	86.16			
TKW0720519	(0-180) Adj. Angle 3/4"x3/4" with Digital Display	3/4"x3/4"	1:1	6000	X	X	65	3/4"	3/4"	
TKW0720516	(0-180) Adj. Angle Ø16x17 with Digital Display	Ø16x17	1:1	6000	X	X	65	16	17	
TKW0720522	(0-180) Adj. Angle Ø22x19 with Digital Display	Ø22x19	1:1	6000	X	X	66	22	19	

Note : Wrenches are provided with the purchase of Specialty Toolholders

DRIVEN

EX308/310/508/510/708/710/910 - TC350MC - TT350MC - NEX108/110/908/910 - LA200/250 M/Y - LA250YS 15ST. - FX-800 - VTL450M - EX2000M/Y - LX2500M

BROACHING/SLOTING DRIVEN TOOL 50mm STROKE H=90mm

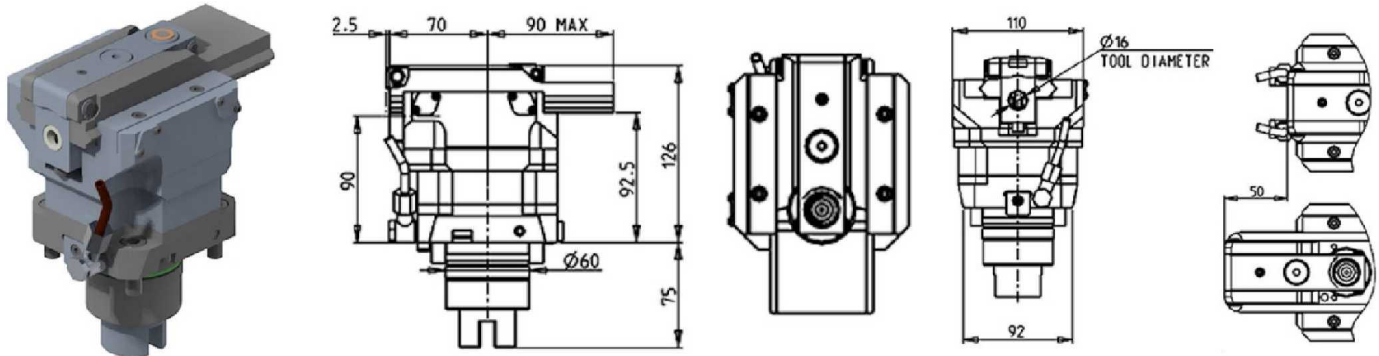

PartNumber	Description	I	MAX RPM	Reversible	Ext Cool
TKW0590100	Broaching/Slotting Driven Tool 50mm Stroke	4:1	2000	X	X

BROACHING/SLOTING DRIVEN TOOL 25mm STROKE H=90mm

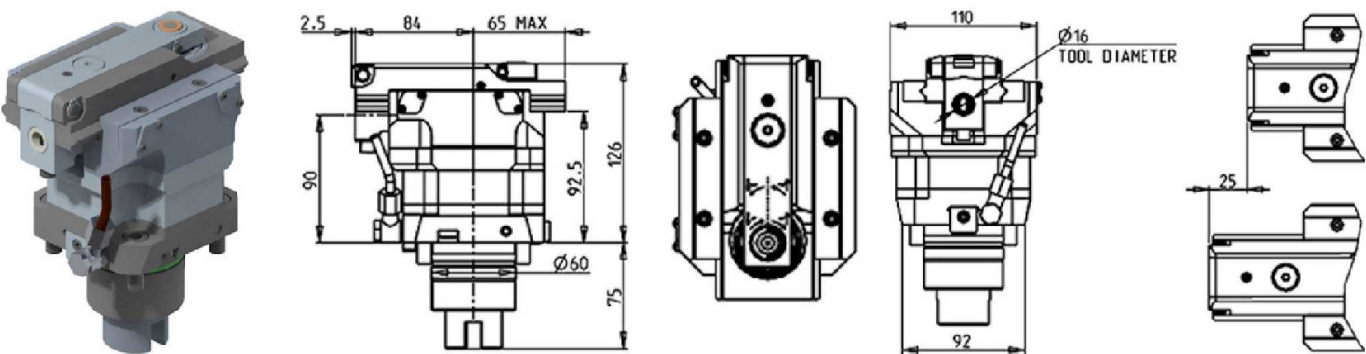

PartNumber	Description	I	MAX RPM	Reversible	Ext Cool
TKW0590200	Broaching/Slotting Driven Tool 25mm Stroke	4:1	2400	X	X

STATIC

EX308/310/508/510/708/710/910 - TC350MC - TT350MC - NEX108/110/908/910 - LA200/250 M/Y - LA250YS 15ST. - FX-800 - MX-800 - VTL450M - EX2000M/Y - LX2500M

RADIAL SINGLE STATIC TOOL H=75mm

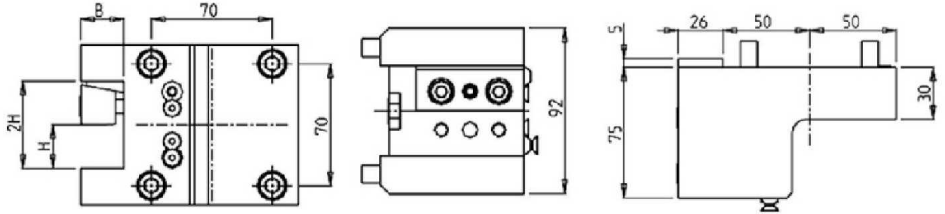
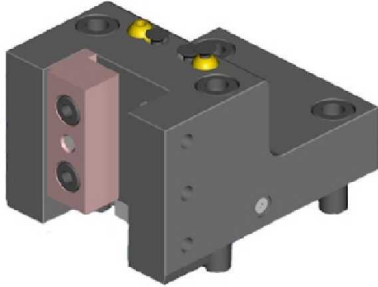

PartNumber	Description	# of Tools	Dimensions	B	H
TKW0882500	Radial Single Static Tool 25mm	1	mm	25	25

EX708/710/910 - NEX108/110/908/910 - LA200/250Y - LA250YS 15ST. - FX-800 - EX2000Y

RADIAL SINGLE SIDE TWIN STATIC TOOL

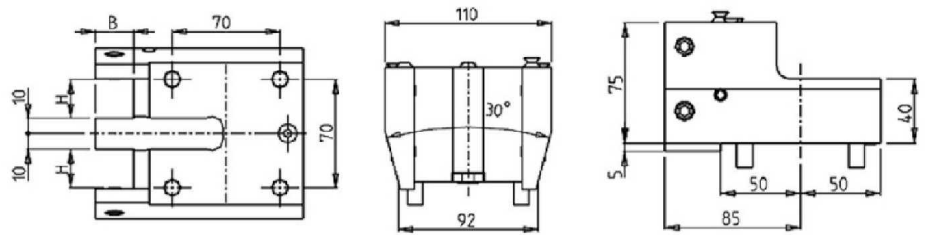
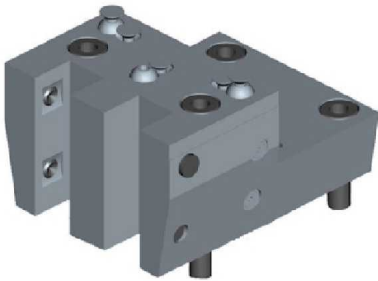

PartNumber	Description	Dimensions	H	B
TKW0902500	Radial Single Side Twin Static Tool 25mm	mm	25	25

STATIC

EX308/310/508/510/708/710/910 - TC350MC - TT350MC - NEX108/110/908/910 - LA200/250 M/Y - LA250YS 15ST. - FX-800 - MX-800 - VTL450M - EX2000M/Y - LX2500M

AXIAL SINGLE STATIC TOOL

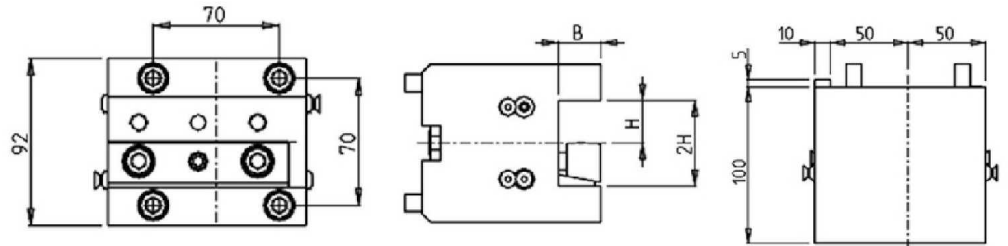
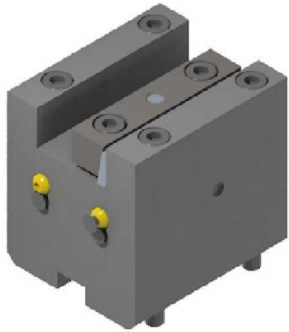

PartNumber	Description	# of Tools	Dimensions	B	H
TKW0892500	Axial Single Static Tool 25mm	1	mm	25	25

EX308/310 - NEX108/110 - LA200/250 M/Y - LA250YS 15ST.

AXIAL DOUBLE BORING BAR HOLDER

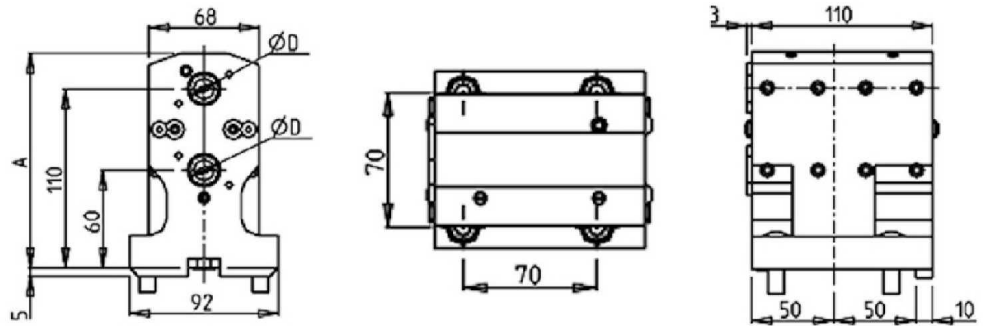

PartNumber	Description	# of Tools	Cool Thru	Ext Cool	Dimensions	A	D
TKW0872000	Axial Double BBH 20mm	2	X	X	mm	132	20
TKW0872500	Axial Double BBH 25mm	2	X	X	mm	134	25
TKW0873200	Axial Double BBH 32mm	2	X	X	mm	134	32
KIT1000015	20mm Plug to Make BBH Cool Thru*						
KIT1000006	25mm or 1" Plug to Make BBH Cool Thru*						
KIT1000001	32mm or 1-1/4" Plug to Make BBH Cool Thru*						

STATIC

EX308/310/508/510/708/710/910 - TC350MC - TT350MC - NEX108/110/908/910 - LA200/250 M/Y - LA250YS 15ST. - FX-800 - MX-800 - VTL450M - EX2000M/Y - LX2500M

RADIAL SINGLE STATIC TOOL CAPTO C4

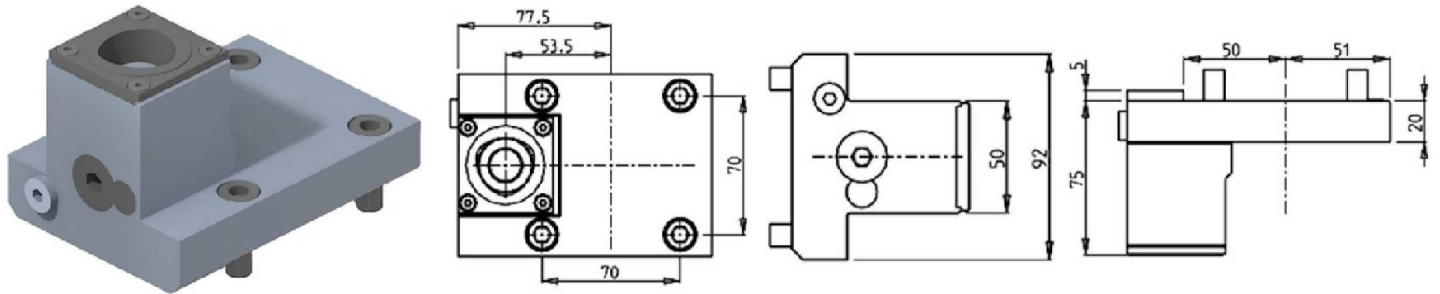

PartNumber	Description	# of Tools	Cool Thru	Ext Cool	Size
TKW0844010	Radial Single Static Tool Capto C4 Right Version	1	X	X	C4
TKW0844010LC	Radial Single Static Tool Capto C4 Left Version	1	X	X	C4

EX308/310/508/510/708/710/910 - TC350MC - TT350MC - NEX108/110/908/910 - LA200/250 M/Y - LA250YS 15ST. - FX-800 - VTL450M - EX2000M/Y - LX2500M

AXIAL SINGLE STATIC TOOL CAPTO C4

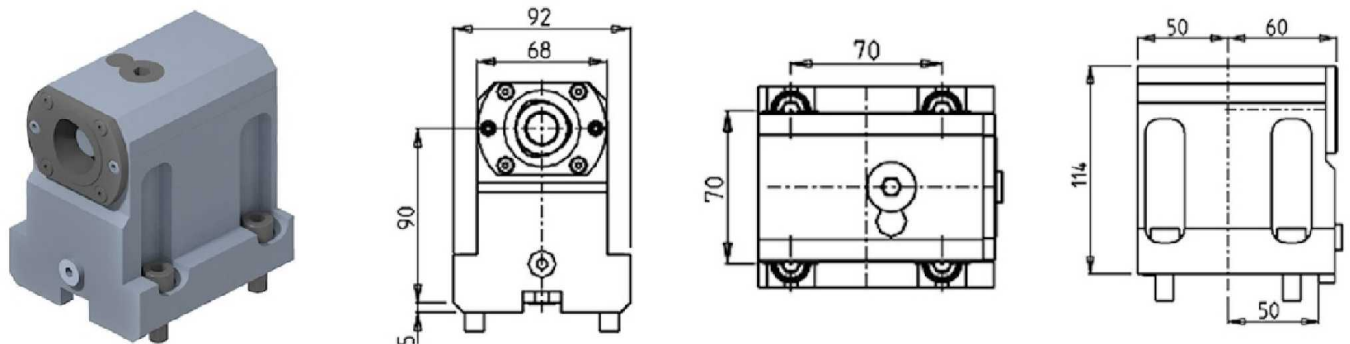

PartNumber	Description	# of Tools	Cool Thru	Ext Cool	Size
TKW0854010	Axial Single Static Tool Capto C4 Right Version	1	X	X	C4
TKW0854010LC	Axial Single Static Tool Capto C4 Left Version	1	X	X	C4

DRIVEN

TMM200/250 - TNR200

RADIAL DRIVEN TOOL VDI40

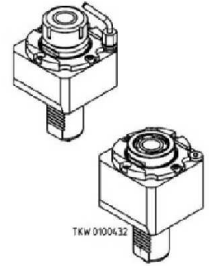
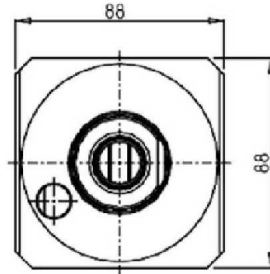
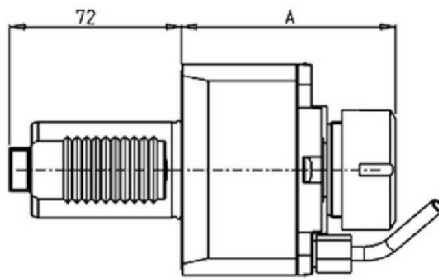
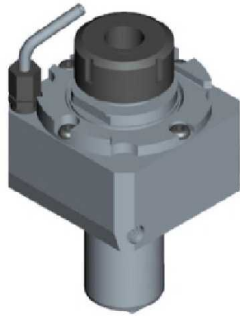

PartNumber	Description	Takisawa Code	Spindle	I	RPM	Cool Thru	Ext Cool	A
TKW0100132	Radial Driven VDI40 ER32	GM81998-640A	ER32	1:1	6000		X	89.66
TKW0100432	Radial Driven VDI40 ERA32 Cool Thru*		ERA32	1:1	6000	X	X	84

*Coolant Thru tools are designed for 400 psi MAX.
They require 5 Micron Filtration and **CANNOT** be run dry.

DRIVEN

TMM200/250 - TNR200

AXIAL DRIVEN TOOL FOR MAIN SPINDLE VDI40

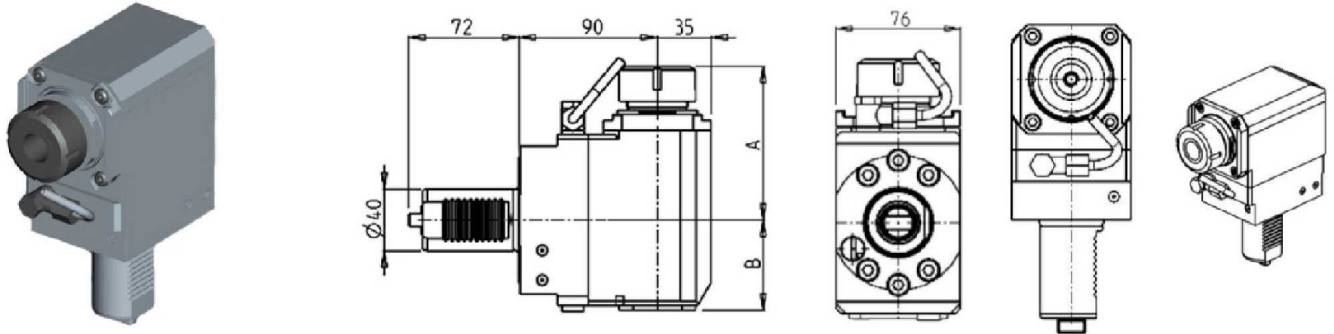

PartNumber	Description	Takisawa Code	Spindle	I	RPM	Cool Thru	Ext Cool	A	B
TKW0090132	Axial VDI40 Driven Tool ER32	GM81998-642A	ER32	1:1	6000		X	99.7	58.5
TKW0090232	Axial VDI40 Driven Tool ER32 Cool Thru*		ER32	1:1	6000	X	X	99.7	69.5
TKW0090140	Axial VDI40 Driven Tool ER40		ER40	1:1	6000		X	103.7	58.5
TKW0090240	Axial VDI40 Driven Tool ER40 Cool Thru*		ER40	1:1	6000	X	X	103.7	69.5

* Coolant Thru tools are designed for 1000 psi.
They require 5 Micron Filtration and **CANNOT** be run dry.

QUICK CHANGE AXIAL MTSK DRIVEN TOOL FOR MAIN SPINDLE VDI40

Please see Accessories for MTSK Clamping Units

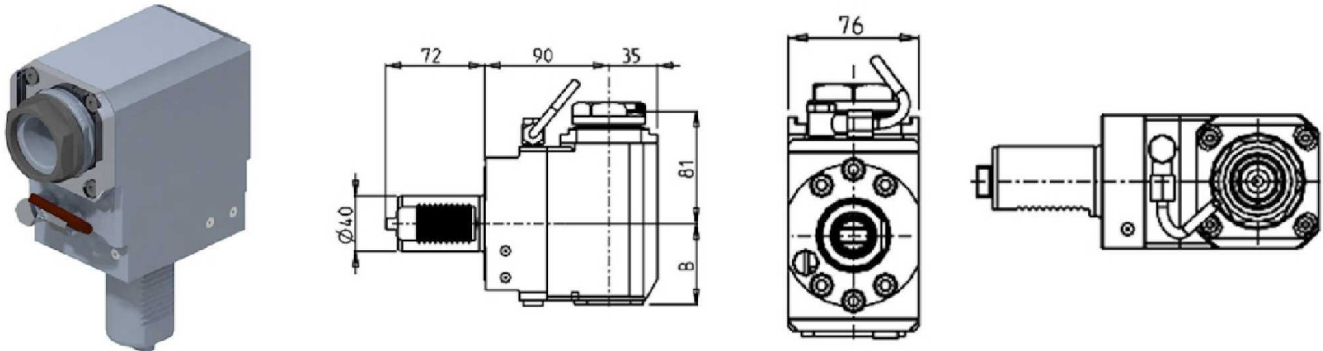

PartNumber	Description	Spindle	I	RPM	Cool Thru	Ext Cool	B
TKW0510140	Axial VDI40 MTSK-40 Driven Tool	MTSK-40	1:1	6000		X	58.5
TKW0510240	Axial VDI40 MTSK-40 Driven Tool Cool Thru*	MTSK-40	1:1	6000	X	X	69.5

* Coolant Thru tools are designed for 1000 psi.
They require 5 Micron Filtration and **CANNOT** be run dry.

DRIVEN

TMM200/250 - TNR200

AXIAL DRIVEN TOOL FOR MAIN SPINDLE VDI40

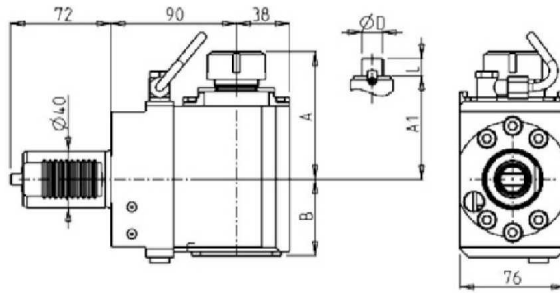

PartNumber	Description	Spindle	I	RPM	Cool Thru	Ext Cool	A	A1	B	D	L
TKW0140125	Axial VDI40 ER25	ER25	1:1	6000		X	91.16		54.5		
TKW0140225	Axial VDI40 ER25 Cool Thru*	ER25	1:1	6000	X	X	91.16		67		
TKW0140325	Axial VDI40 ERA25	ERA25	1:1	6000		X	65		54.5		
TKW0140425	Axial VDI40 ERA25 Cool Thru*	ERA25	1:1	6000	X	X	65		67		
TKW0140132	Axial VDI40 ER32	ER32	1:1	6000		X	93.66		54.5		
TKW0140232	Axial VDI40 ER32 Cool Thru*	ER32	1:1	6000	X	X	93.66		67		
TKW0140140	Axial VDI40 ER40	ER40	1:1	6000		X	98.16		54.5		
TKW0140240	Axial VDI40 ER40 Cool Thru*	ER40	1:1	6000	X	X	98.16		67		
TKW0140516	Axial VDI40 Mill Head 16X17	16x17	1:1	6000		X		67.5	54.5	16	17
TKW0140522	Axial VDI40 Mill Head 22X19	22x19	1:1	6000		X		67.5	54.5	22	19
TKW0140527	Axial VDI40 Mill Head 27X21	27x21	1:1	6000		X		70	54.5	27	21

* Coolant Thru tools are designed for 1000 psi.
They require 5 Micron Filtration and **CANNOT** be run dry.

DRIVEN

TMM200/250 - TNR200

QUICK CHANGE AXIAL MTSK DRIVEN TOOL FOR MAIN SPINDLE VDI40

Please see Accessories for MTSK Clamping Units

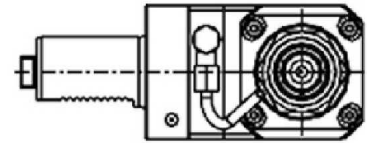
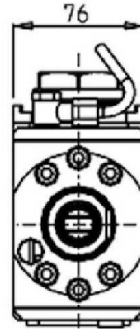
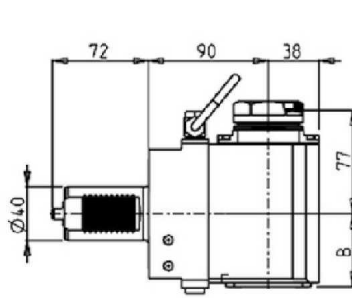

PartNumber	Description	Spindle	I	RPM	Cool Thru	Ext Cool	B
TKW0520140	Axial VDI40 MTSK-40 Driven Tool	MTSK-40	1:1	6000		X	54.5
TKW0520240	Axial VDI40 MTSK-40 Driven Tool Cool Thru*	MTSK-40	1:1	6000	X	X	67

* Coolant Thru tools are designed for 1000 psi.
They require 5 Micron Filtration and **CANNOT** be run dry.

AXIAL DRIVEN TOOL FOR SUBSPINDLE VDI40

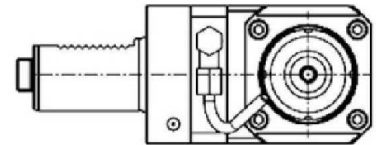
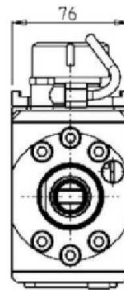
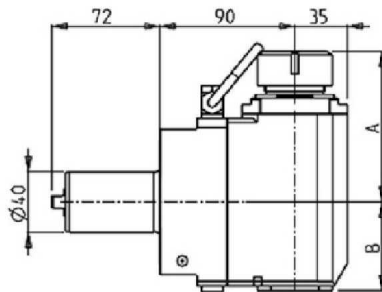

PartNumber	Description	Spindle	I	RPM	Cool Thru	Ext Cool	A	B
TKW0091132	Axial VDI40 Driven Tool ER32	ER32	1:1	6000		X	99.7	58.5
TKW0091232	Axial VDI40 Driven Tool ER32 Cool Thru*	ER32	1:1	6000	X	X	99.7	69.5
TKW0091140	Axial VDI40 Driven Tool ER40	ER40	1:1	6000		X	103.7	58.5
TKW0091240	Axial VDI40 Driven Tool ER40 Cool Thru*	ER40	1:1	6000	X	X	103.7	69.5

* Coolant Thru tools are designed for 1000 psi.
They require 5 Micron Filtration and **CANNOT** be run dry.

DRIVEN

TMM200/250 - TNR200

QUICK CHANGE AXIAL MTSK DRIVEN TOOL FOR SUBSPINDLE VDI40

Please see Accessories for MTSK Clamping Units

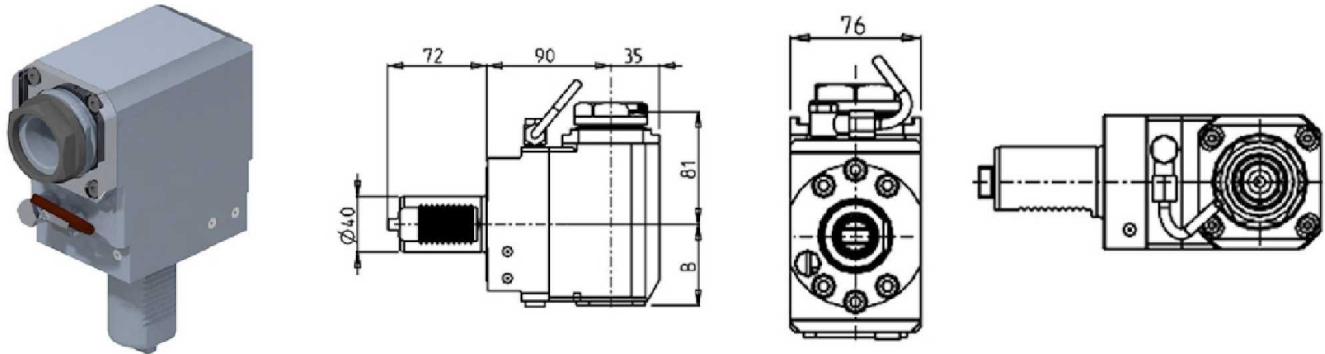

PartNumber	Description	Spindle	I	RPM	Cool Thru	Ext Cool	B
TKW0511140	Axial VDI40 MTSK-40 Driven Tool	MTSK-40	1:1	6000		X	58.5
TKW0511240	Axial VDI40 MTSK-40 Driven Tool Cool Thru*	MTSK-40	1:1	6000	X	X	69.5

* Coolant Thru tools are designed for 1000 psi.
They require 5 Micron Filtration and **CANNOT** be run dry.

DRIVEN

TMM200/250 - TNR200

AXIAL DRIVEN TOOL FOR SUBSPINDLE VDI40

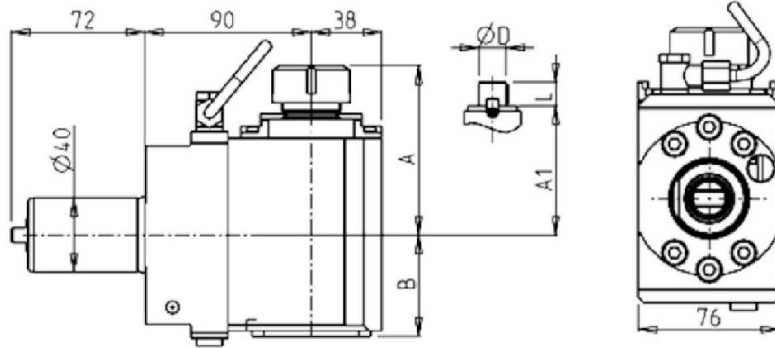
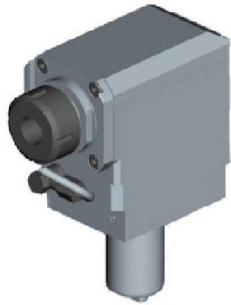

PartNumber	Description	Spindle	I	RPM	Cool Thru	Ext Cool	A	A1	B	D	L
TKW0141125	Axial VDI40 Sub-Spindle ER25	ER25	1:1	6000		X	91.16		54.5		
TKW0141225	Axial VDI40 Sub-Spindle ER25	ER25	1:1	6000	X	X	91.16		67		
TKW0141325	Axial VDI40 Sub-Spindle ERA25	ERA25	1:1	6000		X	65		54.5		
TKW0141425	Axial VDI40 Sub-Spindle ERA25	ERA25	1:1	6000	X	X	65		67		
TKW0141132	Axial VDI40 Sub-Spindle ER32	ER32	1:1	6000		X	93.66		54.5		
TKW0141232	Axial VDI40 Sub-Spindle ER32	ER32	1:1	6000	X	X	93.66		67		
TKW0141140	Axial VDI40 Sub-Spindle ER40	ER40	1:1	6000		X	98.16		54.5		
TKW0141240	Axial VDI40 Sub-Spindle ER40	ER40	1:1	6000	X	X	98.16		67		
TKW0141516	Axial VDI40 Sub-Spindle 16x17	16x17	1:1	6000		X		67.5	54.5	16	17
TKW0141522	Axial VDI40 Sub-Spindle 22x19	22x19	1:1	6000		X		67.5	54.5	22	19
TKW0141527	Axial VDI40 Sub-Spindle 27x21	27x21	1:1	6000		X		70	54.5	27	21

* Coolant Thru tools are designed for 1000 psi.
They require 5 Micron Filtration and **CANNOT** be run dry.

DRIVEN

TMM200/250 - TNR200

QUICK CHANGE AXIAL MTSK DRIVEN TOOL FOR SUBSPINDLE VDI40

Please see Accessories for MTSK Clamping Units

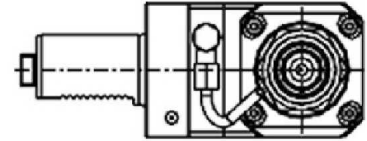
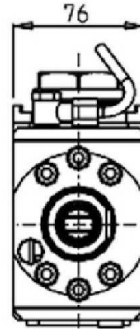
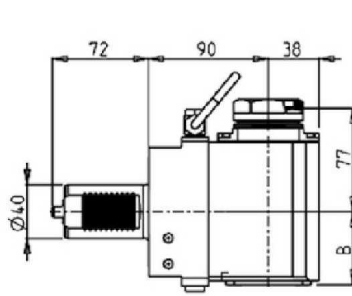

PartNumber	Description	Spindle	I	RPM	Cool Thru	Ext Cool	B
TKW0521140	Axial VDI40 MTSK-40 Driven Tool	MTSK-40	1:1	6000		X	54.5
TKW0521240	Axial VDI40 MTSK-40 Driven Tool Cool Thru*	MTSK-40	1:1	6000	X	X	67

* Coolant Thru tools are designed for 1000 psi.
They require 5 Micron Filtration and **CANNOT** be run dry.

DRIVEN

TMM200/250 - TNR200

AXIAL GEARED-UP 1:3 DRIVEN TOOL FOR MAIN SPINDLE VDI40 H=90mm

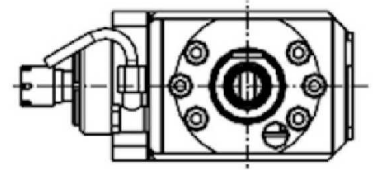
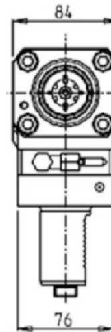
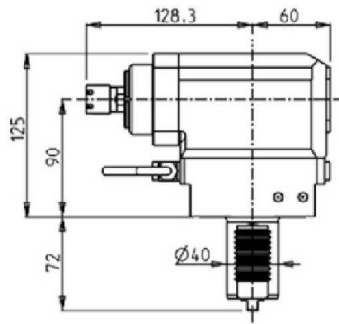
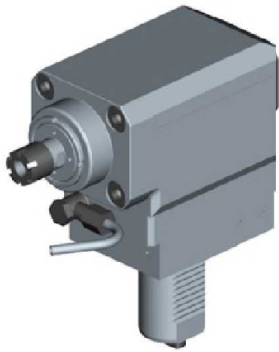

PartNumber	Description	Spindle	I	RPM	Ext Cool
TKW0260016	Axial Geared-Up 1:3 Driven Tool VDI40	ER16	1:3	18000	X

AXIAL GEARED-UP 1:3 DRIVEN TOOL FOR SUBSPINDLE VDI40 H=90mm

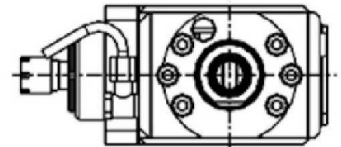
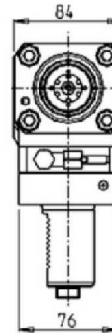
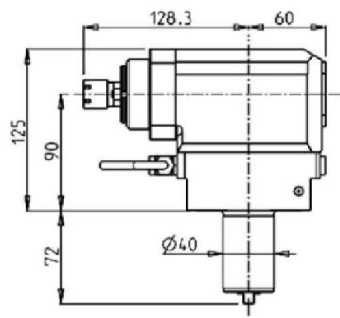
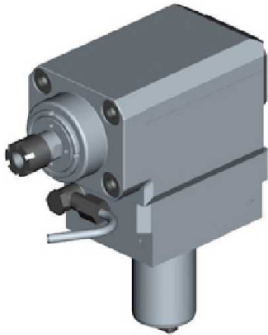

PartNumber	Description	Spindle	I	RPM	Ext Cool
TKW0261016	Axial Geared-Up 1:3 Driven Tool VDI40	ER16	1:3	18000	X

DRIVEN

TMM200/250 - TNR200

DRIVEN GEAR HOBBER VDI40

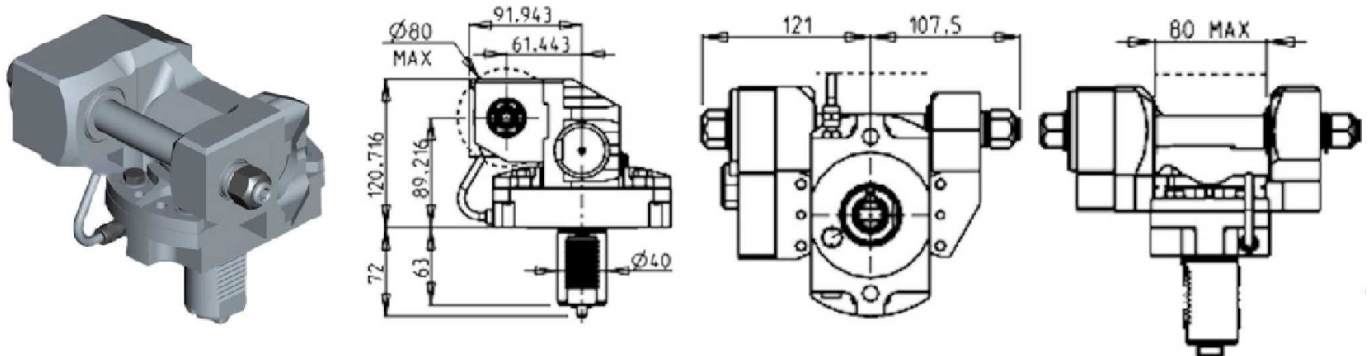

PartNumber	Description	I	MAX RPM	Ext Cool	D (mm)	D (inch)	VDI
TKW0151100	Driven Gear Hobber VDI40 1:1	1:1	4000	X	16-22-27-32	3/4"-1"-1 1/4"	Right
TKW0151110	Driven Gear Hobber VDI40 1:1	1:1	4000	X	16-22-27-32	3/4"-1"-1 1/4"	Left
TKW0152100	Driven Gear Hobber VDI40 Geared-Down 2:1	2:1	2000	X	16-22-27-32	3/4"-1"-1 1/4"	Right
TKW0152110	Driven Gear Hobber VDI40 Geared-Down 2:1	2:1	2000	X	16-22-27-32	3/4"-1"-1 1/4"	Left

Note : Wrenches are provided with the purchase of Specialty Toolholders

DRIVEN

NEX315/715 - LS800M - VTL750M - LA350M - LA250YS 12ST.

RADIAL DRIVEN TOOL

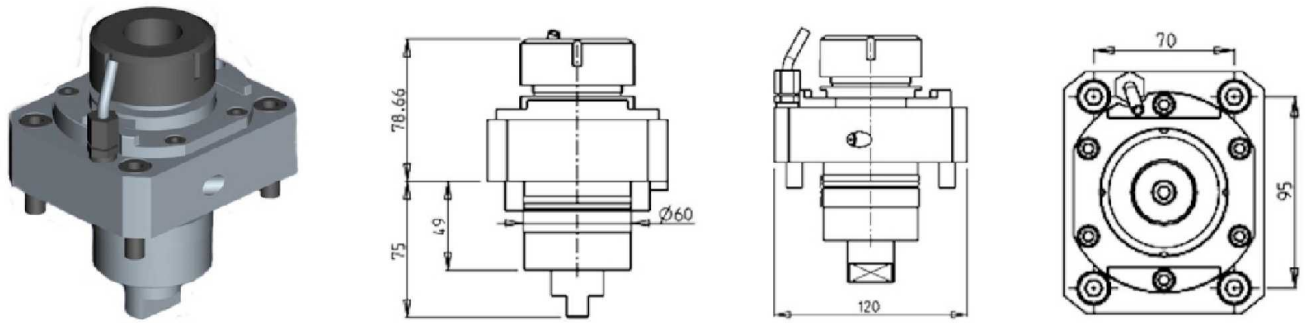

PartNumber	Description	Spindle	I	RPM	Ext Cool
TKW0170140	Radial Driven Tool ER40	ER40	1:1	3500	X

RADIAL DRIVEN TOOL HIGH PRESSURE

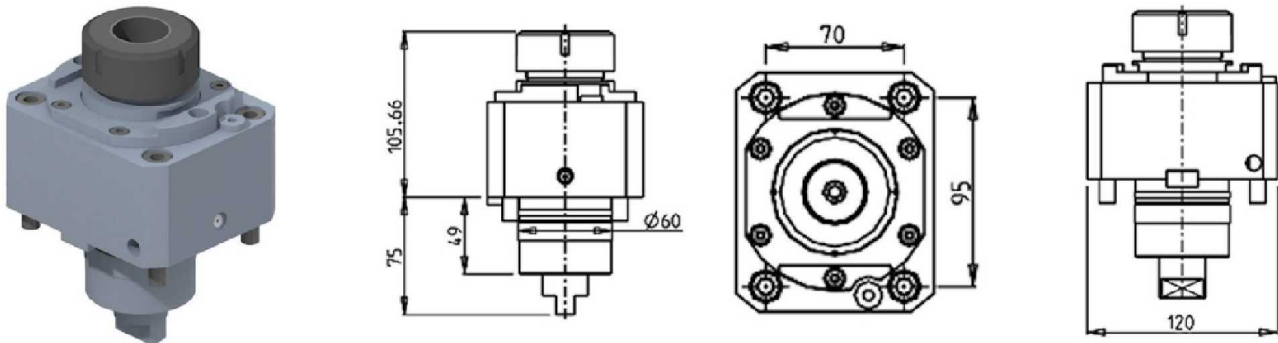

PartNumber	Description	Spindle	I	RPM	Cool Thru	Ext Cool
TKW0660140	Radial Driven Tool ER40 Cool Thru*	ER40	1:1	3500	X	X

* Coolant Thru tools are designed for 1000 psi.
They require 5 Micron Filtration and **CANNOT** be run dry.

DRIVEN

NEX315/715 - LS800M - VTL750M - LA350M - LA250YS 12ST.

RADIAL INVERTED DRIVEN TOOL REDIRECTED IN Z BY 180mm

For machining internal holes with Ø120 min. hole

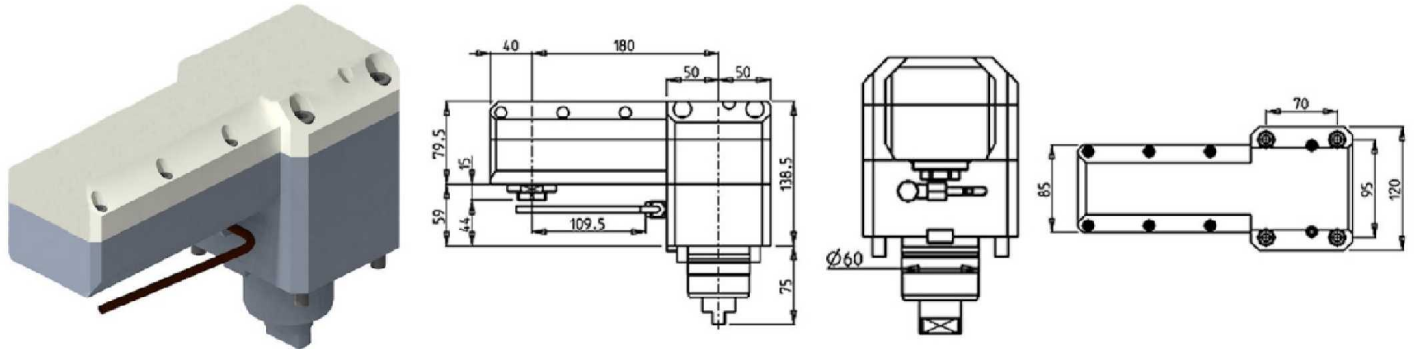

PartNumber	Description	Spindle	I	MAX RPM	Ext Cool
TKW0790325	Radial Inverted Driven Tool Redirected ERA25	ERA25	1:1	3500	X

DRIVEN

NEX315/715 - LS800M - VTL750M - LA350M - LA250YS 12ST.

AXIAL DRIVEN TOOL

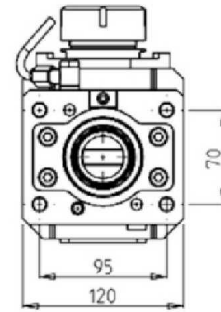
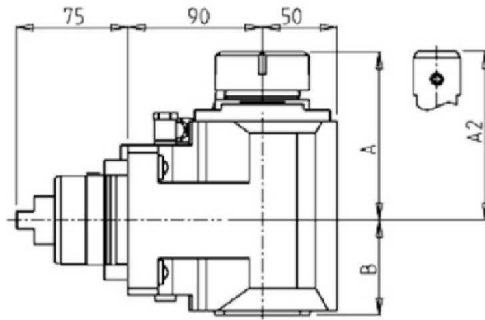

PartNumber	Description	Spindle	I	RPM	Reversible	Cool Thru	Ext Cool	A	A2	B
TKW0160140	Axial Driven Tool ER40	ER40	1:1	3500	X		X	112.16	63.5	
TKW0160240	Axial Driven Tool ER40 Cool Thru*	ER40	1:1	3500	X	X	X	112.16		76
TKW0160532	Axial Driven Tool Weldon 32	Weldon 32	1:1	3500	X		X		107	63.5
TKW0160632	Axial Driven Tool Weldon 32 Cool Thru*	Weldon 32	1:1	3500	X	X	X		107	76

* Coolant Thru tools are designed for 1000 psi.
They require 5 Micron Filtration and **CANNOT** be run dry.

(0-180) ADJUSTABLE ANGLE DRIVEN TOOL H=70mm

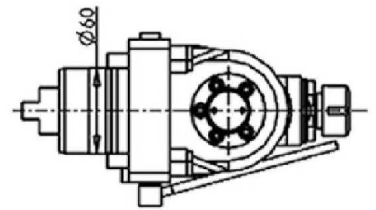
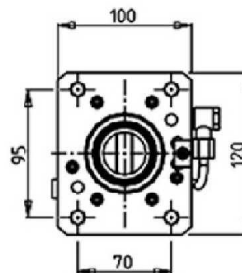
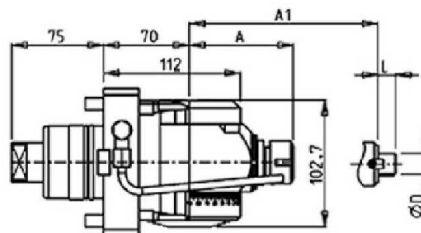

PartNumber	Description	Spindle	I	RPM	Reversible	Ext Cool	A	A1	D	L
TKW0760120	(0-180) Adj. Angle ER20	ER20	1:1	3500	X	X	85.16			
TKW0760125	(0-180) Adj. Angle ER25	ER25	1:1	3500	X	X	86.16			
TKW0760519	(0-180) Adj. Angle 3/4"x3/4"	3/4"x3/4"	1:1	3500	X	X		65	3/4"	3/4"
TKW0760516	(0-180) Adj. Angle 16x17	16x17	1:1	3500	X	X		65	16	17
TKW0760522	(0-180) Adj. Angle 22x19	22x19	1:1	3500	X	X		66	22	19

Note : Wrenches are provided with the purchase of Specialty Toolholders

DRIVEN

NEX315/715 - LS800M - VTL750M - LA350M - LA250YS 12ST.

REINFORCED DRIVEN GEAR HOBBER

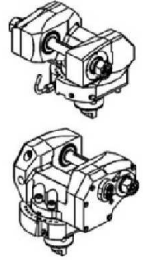
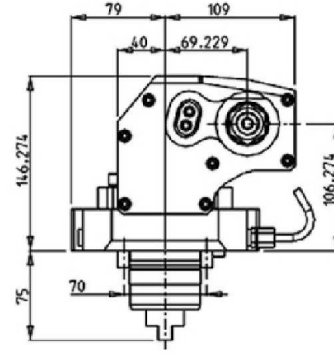
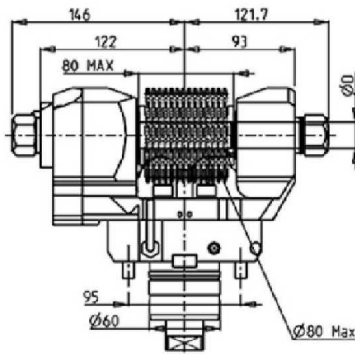
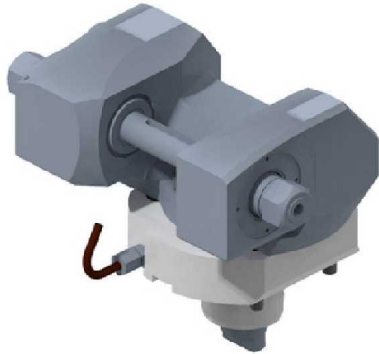

PartNumber	Description	I	MAX RPM	Ext Cool	D (mm)	D (Inch)
TKW0451100	Reinforced Driven Gear Hobb 1:1	1:1	3500	X	16-22-27-32	3/4"-1"-1 1/4"
TKW0452100	Reinforced Driven Gear Hobb Geared-Down 2:1	2:1	1750	X	16-22-27-32	3/4"-1"-1 1/4"

Note : Wrenches are provided with the purchase of Specialty Toolholders

DRIVEN

TY2000Y/YS/CS

RADIAL DRIVEN TOOL

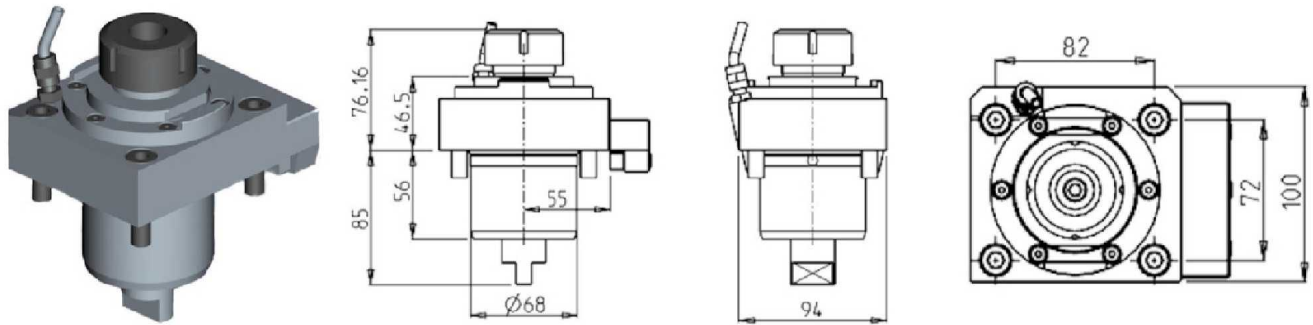

PartNumber	Description	Takisawa Code	Spindle	I	RPM	Ext Cool
TKW0190132	Radial Driven Tool ER32	GM81999-440	ER32	1:1	6000	X

RADIAL SINGLE SIDE TWIN HEAD DRIVEN TOOL IN Y

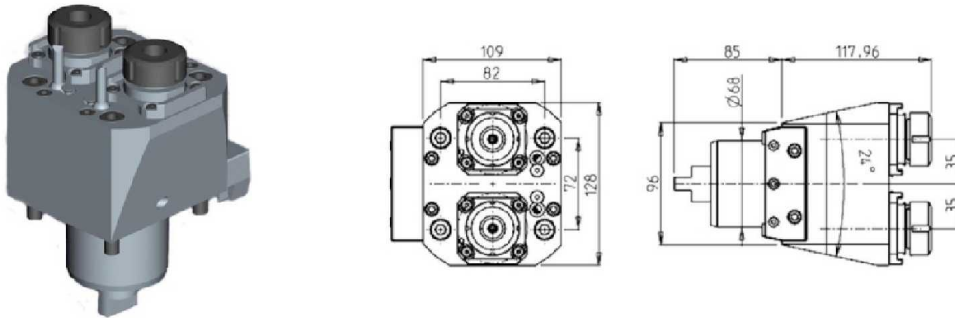

PartNumber	Description	Spindle	I	RPM	Cool Thru	Ext Cool
TKW0210125	Radial Single Side Twin ER25	ER25	1:1	6000		X
TKW0210225	Radial Single Side Twin ER25 Cool Thru*	ER25	1:1	6000	X	X

* Coolant Thru tools are designed for 1000 psi.
They require 5 Micron Filtration and **CANNOT** be run dry.

DRIVEN

TY2000Y/YS/CS

AXIAL DRIVEN TOOL

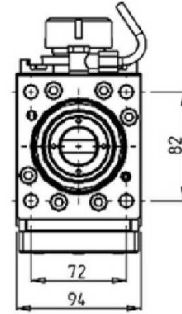
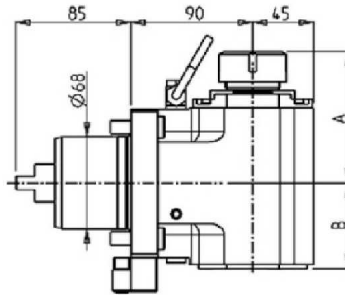

PartNumber	Description	Takisawa Code	Spindle	I	RPM	Cool Thru	Ext Cool	A	B
TKW0180132	Axial Driven Tool ER32	GM81999-441	ER32	1:1	6000		X	96.7	63
TKW0180232	Axial Driven Tool ER32 Cool Thru*		ER32	1:1	6000	X	X	96.7	79.5
TKW0180140	Axial Driven Tool ER40		ER40	1:1	6000		X	99.7	63
TKW0180240	Axial Driven Tool ER40 Cool Thru*		ER40	1:1	6000	X	X	99.7	79.5

* Coolant Thru tools are designed for 1000 psi.
They require 5 Micron Filtration and **CANNOT** be run dry.

AXIAL OPPOSITE FACE DRIVEN TOOL

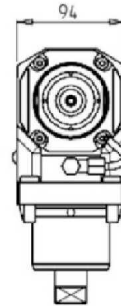
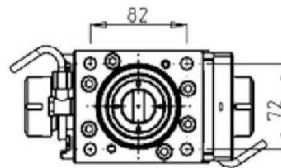
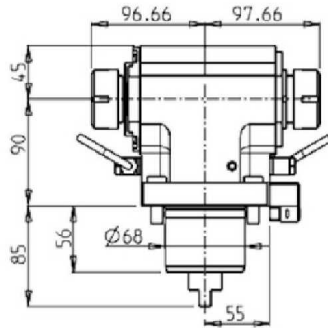

PartNumber	Description	Spindle	Reversible	I	RPM	Ext Cool
TKW0200132	Axial Opposite Face Driven ER32+ER32	ER32+ER32	X	1:1	6000	X

DRIVEN

TS3000/4000/5000 Y/YS 15 ST. - TM4000 12ST.

RADIAL DRIVEN TOOL

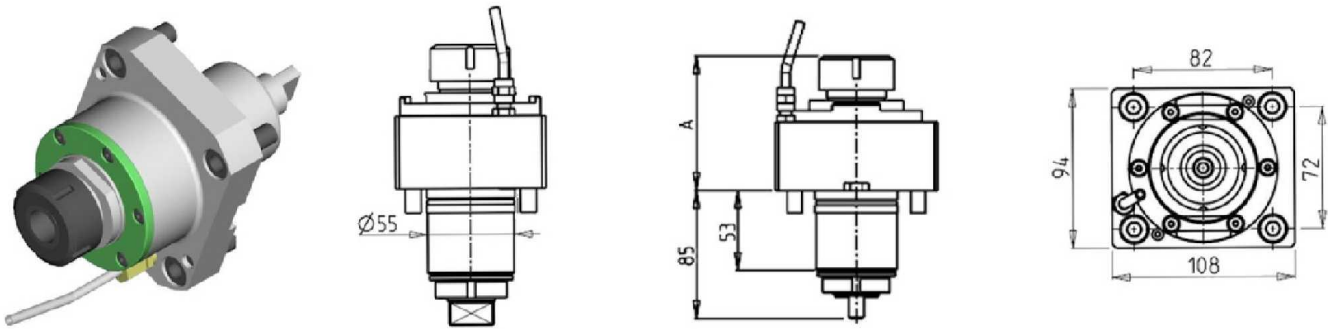

PartNumber	Description	Spindle	I	RPM	Cool Thru	Ext Cool	A
TKW0300132	Radial Driven Tool ER32	ER32	1:1	6000		X	89.16
TKW0800132	Radial Driven Tool ER32 Cool Thru*	ER32	1:1	6000	70 BAR	X	96.41
TKW0300240	Radial Driven Tool ER40 Cool Thru*	ER40	1:1	6000	30 BAR	X	98.16

* Coolant Thru tools are designed for 400/1000 psi.
They require 5 Micron Filtration and **CANNOT** be run dry.
30 BAR=400 PSI 70 BAR=1000 PSI

QUICK CHANGE RADIAL MTSK DRIVEN TOOL

Please see Accessories for MTSK Clamping Units

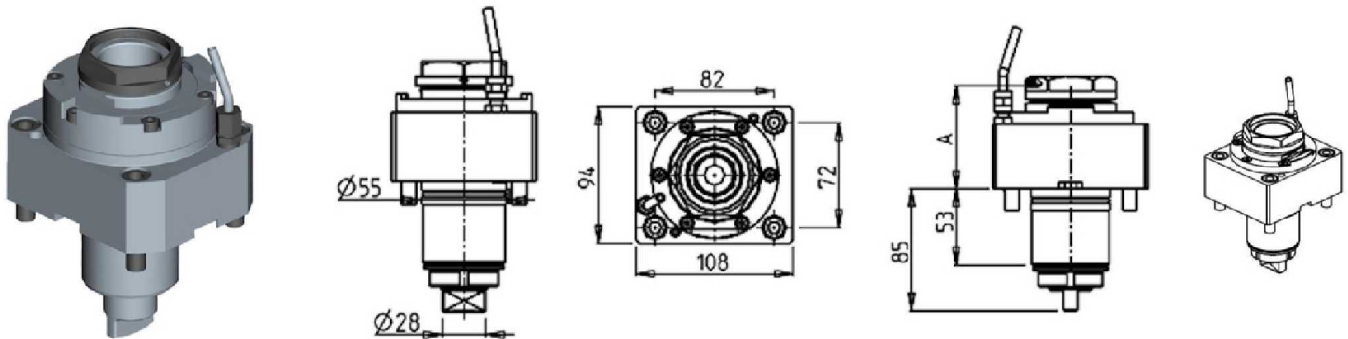

PartNumber	Description	Spindle	I	RPM	Cool Thru	Ext Cool	A
TKW0460150	Radial MTSK-50 Driven Tool	MTSK-50	1:1	6000		X	71.5
TKW0460250	Radial MTSK-50 Driven Tool Cool Thru*	MTSK-50	1:1	6000	X	X	78.5

*Coolant Thru tools are designed for 400 psi MAX.
They require 5 Micron Filtration and **CANNOT** be run dry.

DRIVEN

TS3000/4000/5000 Y/YS 15 ST. - TM4000 12ST.

RADIAL SINGLE SIDE TWIN HEAD DRIVEN TOOL IN Y

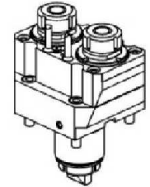
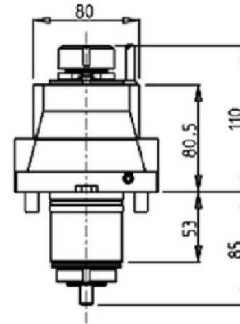
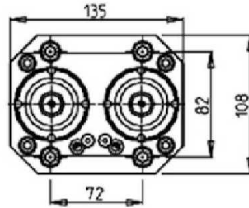
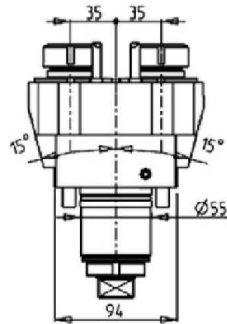
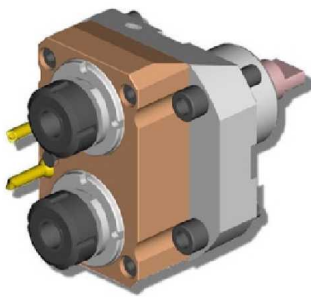

PartNumber	Description	Spindle	I	RPM	Ext Cool
TKW0540225	Radial Single Side Twin ER25	ER25	1:1	6000	X

DRIVEN

TS3000/4000/5000 Y/YS 15 ST. - TM4000 12ST.

AXIAL DRIVEN TOOL

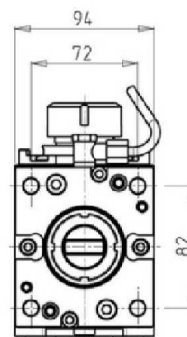
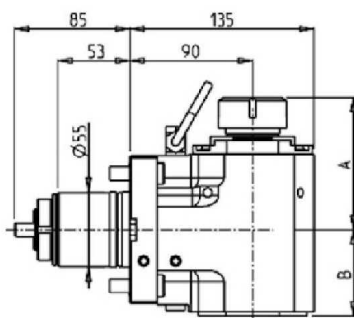

PartNumber	Description	Spindle	I	RPM	Reversible	Cool Thru	Ext Cool	A	B
TKW0310132	Axial Driven Tool ER32	ER32	1:1	6000	X		X	96.7	63
TKW0310232	Axial Driven Tool ER32 Cool Thru*	ER32	1:1	6000	X	X	X	96.7	79.5
TKW0310140	Axial Driven Tool ER40	ER40	1:1	6000	X		X	99.7	63
TKW0310240	Axial Driven Tool ER40 Cool Thru*	ER40	1:1	6000	X	X	X	99.7	79.5

* Coolant Thru tools are designed for 1000 psi.
They require 5 Micron Filtration and **CANNOT** be run dry.

QUICK CHANGE AXIAL MTSK DRIVEN TOOL

Please see Accessories for MTSK Clamping Units

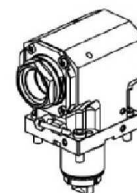
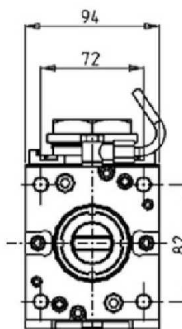
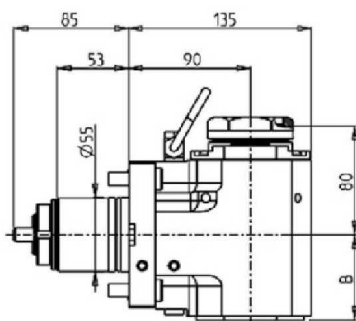
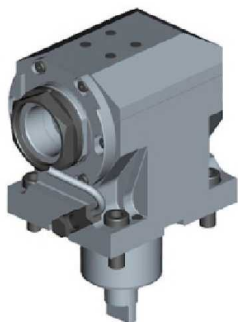

PartNumber	Description	Spindle	I	RPM	Reversible	Cool Thru	Ext Cool	B
TKW0470150	Axial MTSK-50 Driven Tool	MTSK-50	1:1	6000	X		X	63
TKW0470250	Axial MTSK-50 Driven Tool Cool Thru*	MTSK-50	1:1	6000	X	X	X	79.5

* Coolant Thru tools are designed for 1000 psi.
They require 5 Micron Filtration and **CANNOT** be run dry.

DRIVEN

TS3000/4000/5000 Y/YS 15 ST. - TM4000 12ST.

AXIAL OPPOSITE FACE DRIVEN TOOL

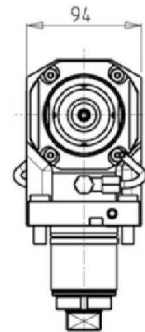
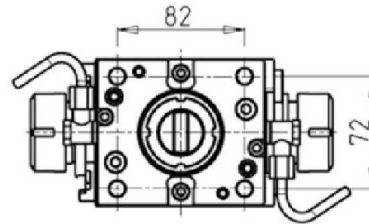
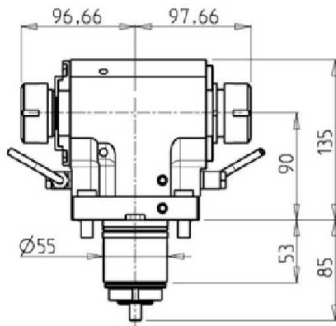

PartNumber	Description	Spindle	I	RPM	Reversible	Ext Cool
TKW0320132	Axial Opposite Face Driven Tool ER32+ER32	ER32+ER32	1:1	6000	X	X

AXIAL SINGLE SIDE TWIN HEAD DRIVEN TOOL IN Y

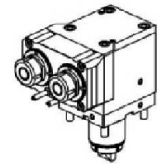
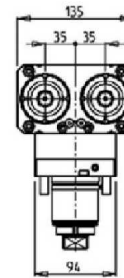
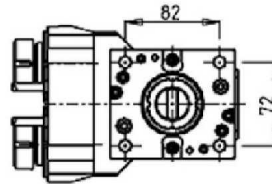
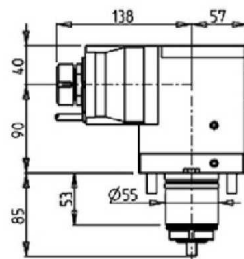
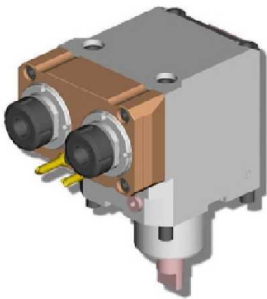

PartNumber	Description	Spindle	I	RPM	Reversible	Ext Cool
TKW0530225	Axial Single Side Twin ER25	ER25	1:1	6000	X	X

DRIVEN

TS3000/4000/5000 Y/YS 15 ST. - TM4000 12ST.

(0-180) ADJUSTABLE ANGLE DRIVEN TOOL

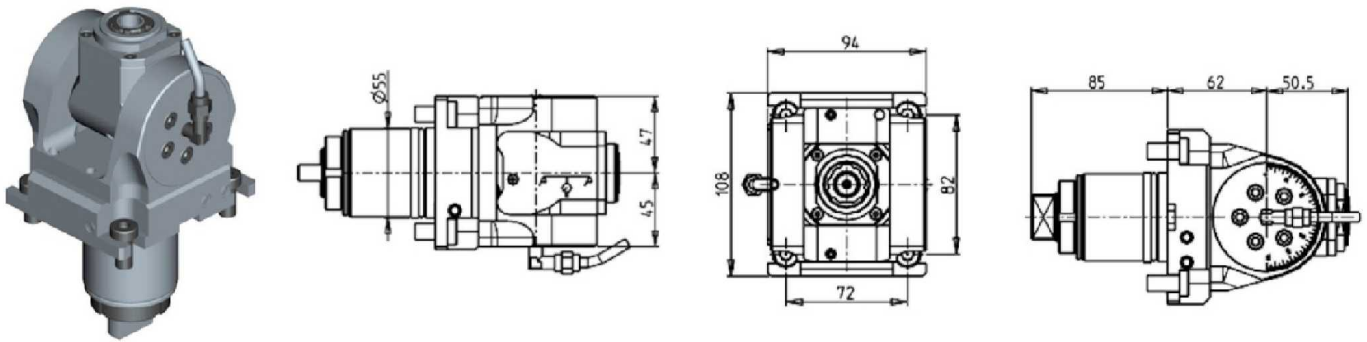

PartNumber	Description	Spindle	I	RPM	Cool Thru	Ext Cool
TKW0330120	(0-180) Adj. Angle ERA20	ERA20	1:1	6000		X
TKW0330220	(0-180) Adj. Angle ERA20 Cool Thru*	ERA20	1:1	6000	X	X

* Coolant Thru tools are designed for 1000 psi.
They require 5 Micron Filtration and **CANNOT** be run dry.

Note :

Wrenches are provided with the purchase of Specialty Toolholders

(0-180) ADJUSTABLE ANGLE DRIVEN TOOL WITH DIGITAL DISPLAY

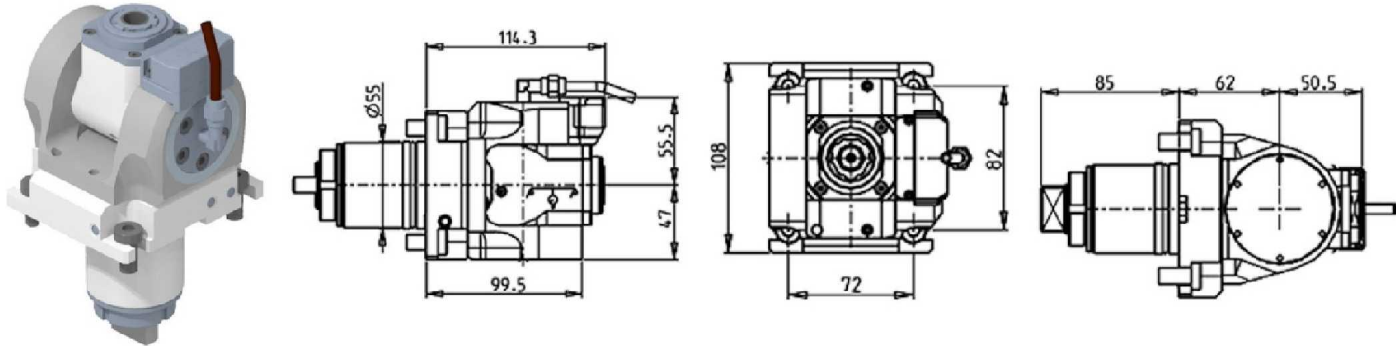

PartNumber	Description	Spindle	I	RPM	Cool Thru	Ext Cool
TKW0335120	(0-180) Adj. Angle ERA20 with Digital Display	ERA20	1:1	6000		X
TKW0335220	(0-180) Adj. Angle ERA20 with Digital Display Cool Thru*	ERA20	1:1	6000	X	X

* Coolant Thru tools are designed for 1000 psi.
They require 5 Micron Filtration and **CANNOT** be run dry.

Note :

Wrenches are provided with the purchase of Specialty Toolholders

DRIVEN

TS3000/4000/5000 Y/YS 15 ST. - TM4000 12ST.

(0-180) ADJUSTABLE ANGLE GEARED-UP 1:2 DRIVEN TOOL

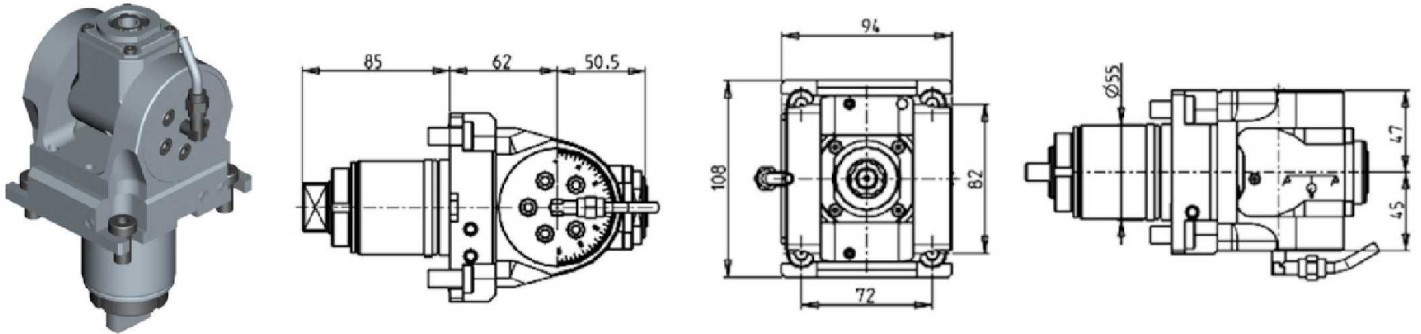

PartNumber	Description	Spindle	I	RPM	Cool Thru	Ext Cool
TKW0330316	(0-180) Adj. Angle Geared-Up 1:2 ERA16	ERA16	1:2	12000		X
TKW0330416	(0-180) Adj. Angle Geared-Up 1:2 ERA16 Cool Thru*	ERA16	1:2	12000	X	X

* Coolant Thru tools are designed for 1000 psi. They require 5 Micron Filtration and **CANNOT** be run dry.

Note :

Wrenches are provided with the purchase of Specialty Toolholders

(0-180) ADJUSTABLE ANGLE GEARED-UP 1:2 DRIVEN TOOL WITH DIGITAL DISPLAY

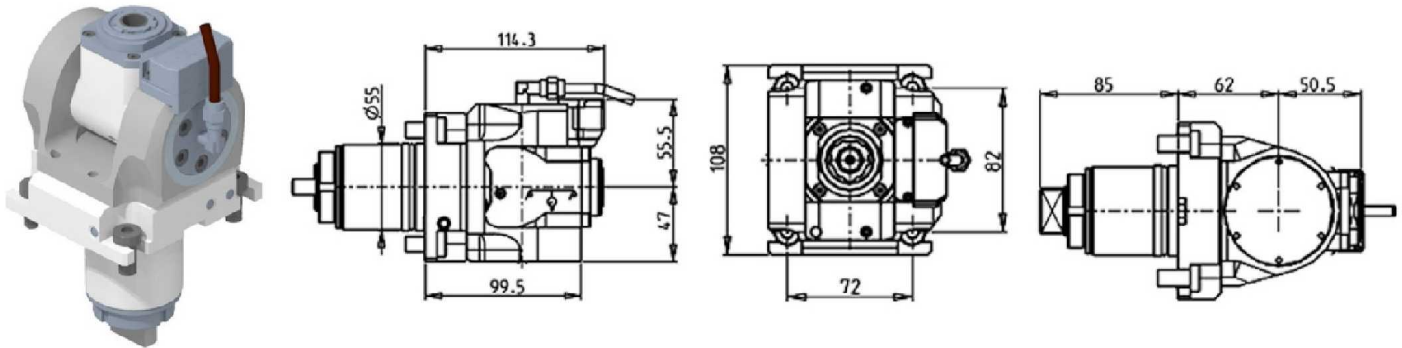

PartNumber	Description	Spindle	I	RPM	Cool Thru	Ext Cool
TKW0335316	(0-180) Adj. Angle ERA16 Geared-Up 1:2 with Digital Display	ERA16	1:2	12000		X
TKW0335416	(0-180) Adj. Angle ERA16 Geared-Up 1:2 with Digital Display Cool Thru*	ERA16	1:2	12000	X	X

* Coolant Thru tools are designed for 1000 psi. They require 5 Micron Filtration and **CANNOT** be run dry.

Note :

Wrenches are provided with the purchase of Specialty Toolholders

DRIVEN

TS3000/4000/5000 Y/YS 15 ST. - TM4000 12ST.

DRIVEN GEAR HOBBER

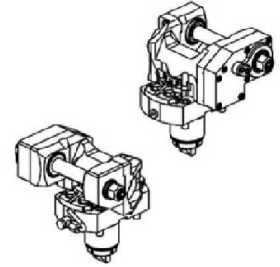
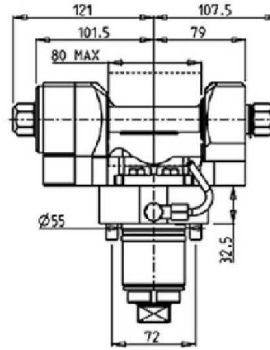
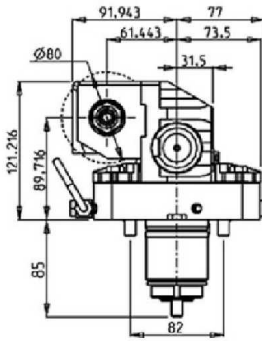
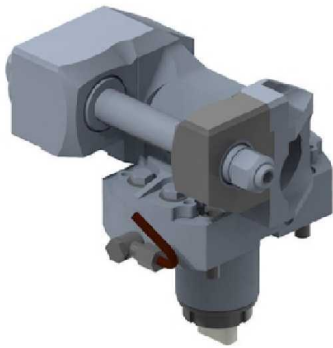

PartNumber	Description	I	MAX RPM	Reversible	Ext Cool	D (mm)	D (Inch)
TKW0861100	Driven Gear Hobb 1:1	1:1	6000	X	X	16-22-27-32	3/4"-1"-1 1/4"
TKW0862100	Driven Gear Hobb Geared-Down 2:1	2:1	3000	X	X	16-22-27-32	3/4"-1"-1 1/4"

Note : Wrenches are provided with the purchase of Specialty Toolholders

STATIC

TS3000/4000/5000 Y/YS 15 ST. - TM4000 12ST.

RADIAL SINGLE STATIC TOOL

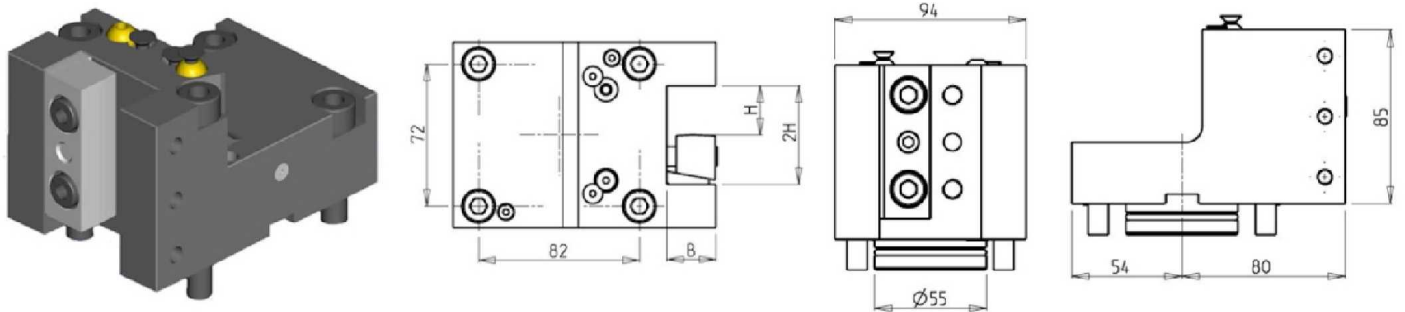

PartNumber	Description	# of Tools	Reversible	Dimensions	B	H
TKW0342500	Radial Single Static Tool 25mm	1/2	X	mm	25	25

RADIAL REAR-SET SINGLE STATIC TOOL

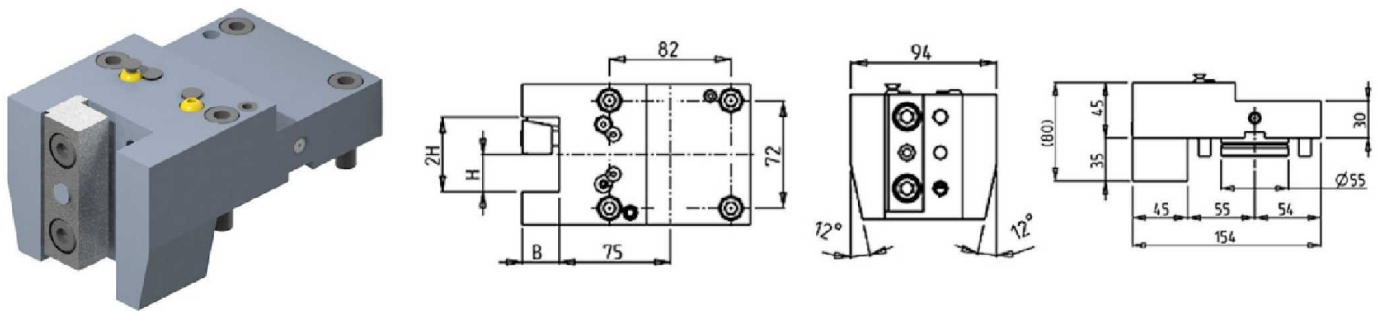

PartNumber	Description	# of Tools	Dimensions	B	H
TKW0582500	Radial Rear-Set Single Static Tool 25mm	1/2	mm	25	25

STATIC

TS3000/4000/5000 Y/YS 15 ST. - TM4000 12ST.

RADIAL SINGLE SIDE TWIN STATIC TOOL

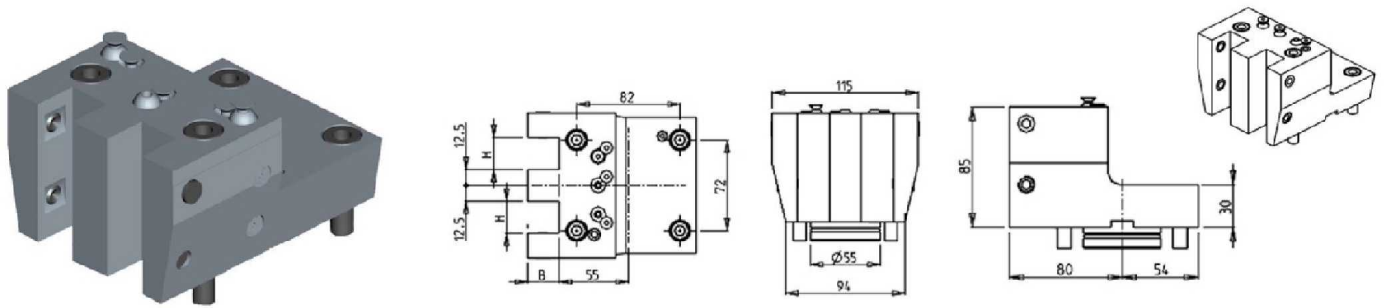

PartNumber	Description	Reversible	Dimensions	H	B
TKW0552500	Radial Single Side Twin Static Tool 25mm	X	mm	25	25

RADIAL DOUBLE STATIC TOOL

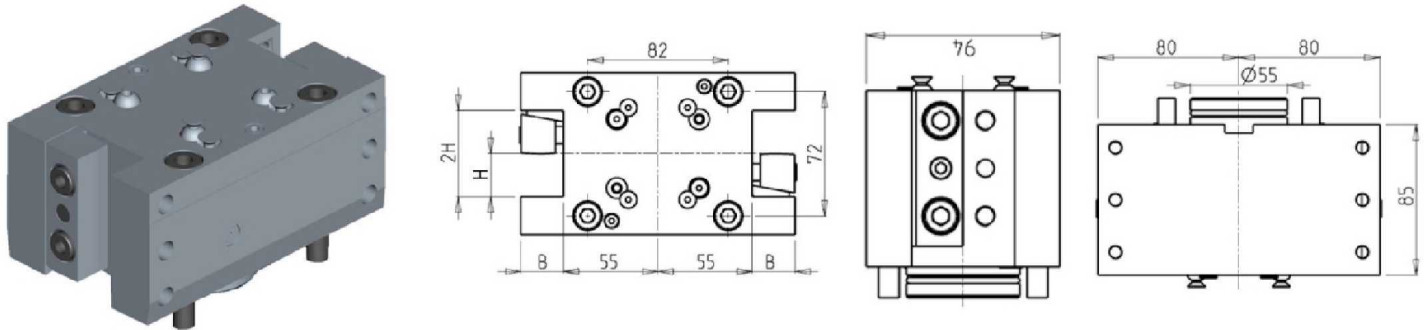

PartNumber	Description	# of Tools	Reversible	Dimensions	B	H
TKW0352500	Radial Double Static Tool 25mm	2/4	X	mm	25	25

STATIC

TS3000/4000/5000 Y/YS 15 ST. - TM4000 12ST.

RADIAL BLADE HOLDER WITH BLADE KIT

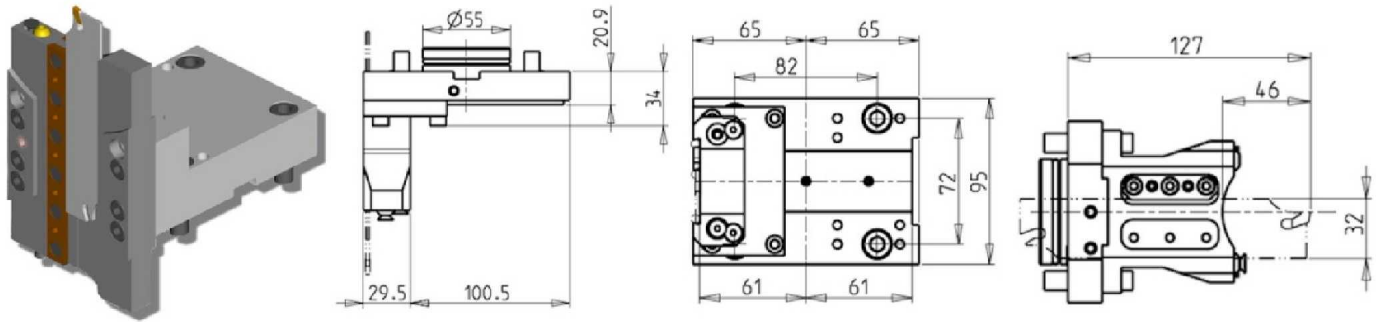

PartNumber	Description	# of Tools	Reversible	Ext Cool
TKW0360132	Radial Blade Holder with Blade Kit	1	X	X
BLADEKIT	Blade Kit: 1 Blade, 10 Inserts			

RADIAL BLADE HOLDER WITH INTERNAL COOLANT-BLADE KIT NOT INCLUDED

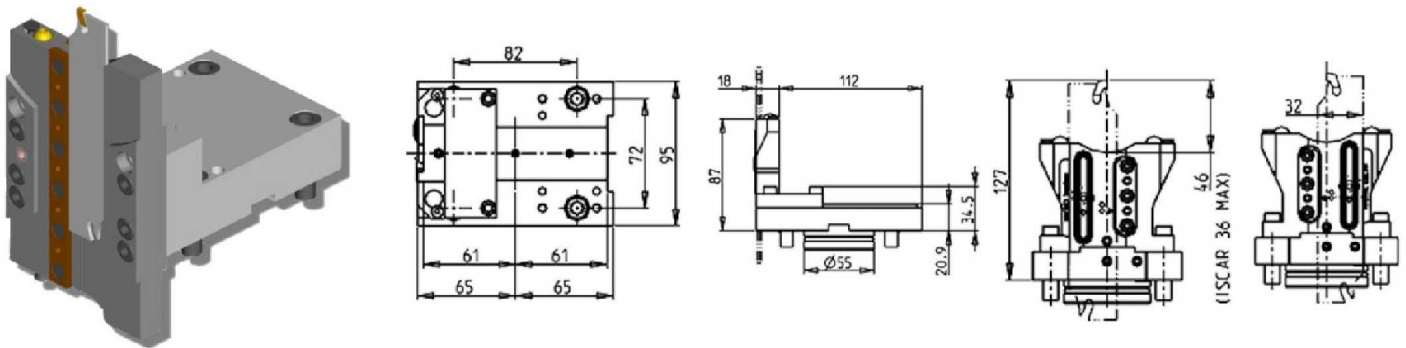

PartNumber	Description	# of Tools	Reversible	Ext Cool	Cool Thru
TKW0370132R	Radial Blade Holder with Cool Thru Right Hand	1	X	X	X
TKW0370132L	Radial Blade Holder with Cool Thru Left Hand	1	X	X	X
COOL THRU BLADEKIT	Blade Kit: 1 Blade, 10 Inserts				

STATIC

TS3000/4000/5000 Y/YS 15 ST. - TM4000 12ST.

AXIAL SINGLE STATIC TOOL

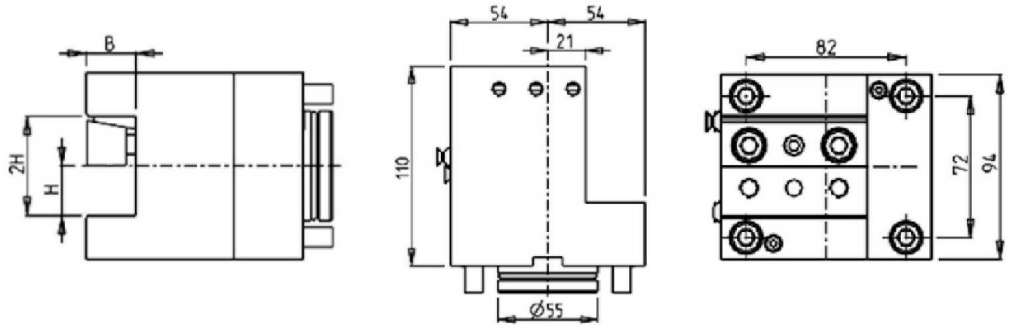
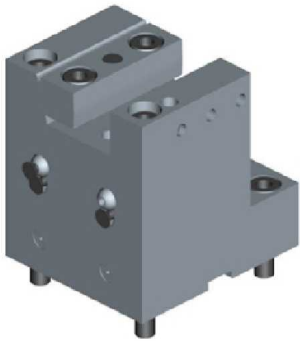

PartNumber	Description	# of Tools	Reversible	Dimensions	B	H
TKW0382500	Axial Single Static Tool 25mm	1/2	X	mm	25	25

AXIAL SINGLE BORING BAR HOLDER H=90mm

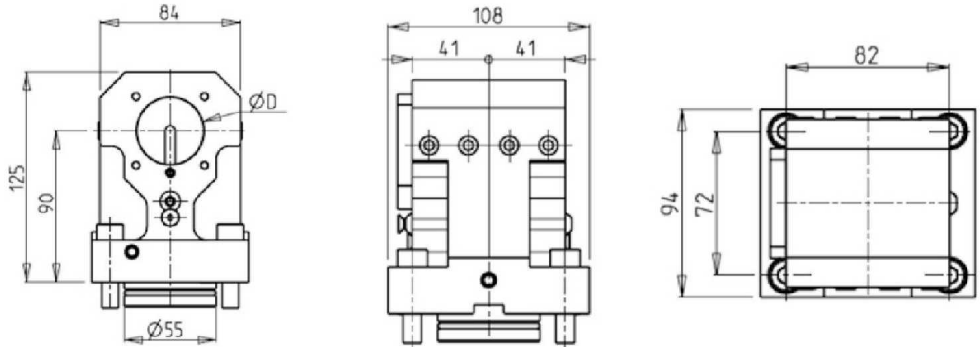
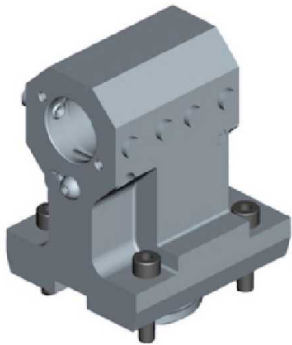

PartNumber	Description	# of Tools	Cool Thru	Ext Cool	Dimensions	D
TKW0394000	Axial Single Boring Bar Holder 40mm	1	X	X	mm	40
KIT1000031	Plug for 40mm BBH to Make Cool Thru*					

STATIC

TS3000/4000/5000 Y/YS 15 ST. - TM4000 12ST.

AXIAL OPPOSITE FACE BORING BAR HOLDER H=90mm

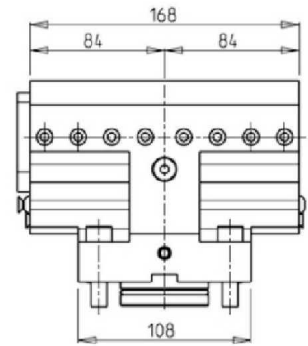
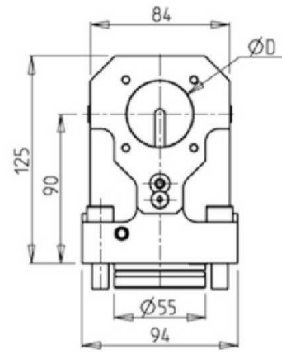

PartNumber	Description	# of Tools	Cool Thru	Ext Cool	Dimensions	D
TKW0414000	Axial Opposite Face Boring Bar Holder 40mm	1	X	X	mm	40
KIT1000031	Plug for 40mm BBH to Make Cool Thru*					

AXIAL DOUBLE BORING BAR HOLDER

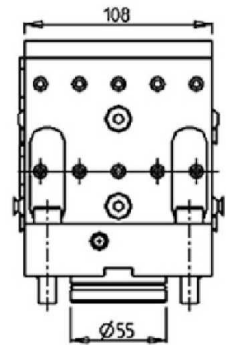
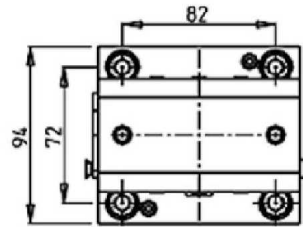
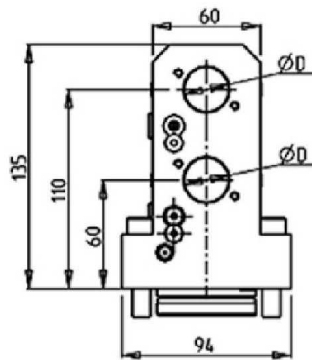
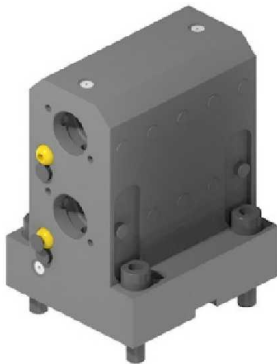

PartNumber	Description	Reversible	Cool Thru	Ext Cool	Dimensions	D
TKW0562500	Axial Double Boring Bar Holder 25mm	X	X	X	mm	25
KIT1000006	25mm or 1" Plug to Make BBH Cool Thru*					

DRIVEN

TS3000/4000/5000 Y/YS 12 ST. (3 KEYS TURRET)

RADIAL DRIVEN TOOL

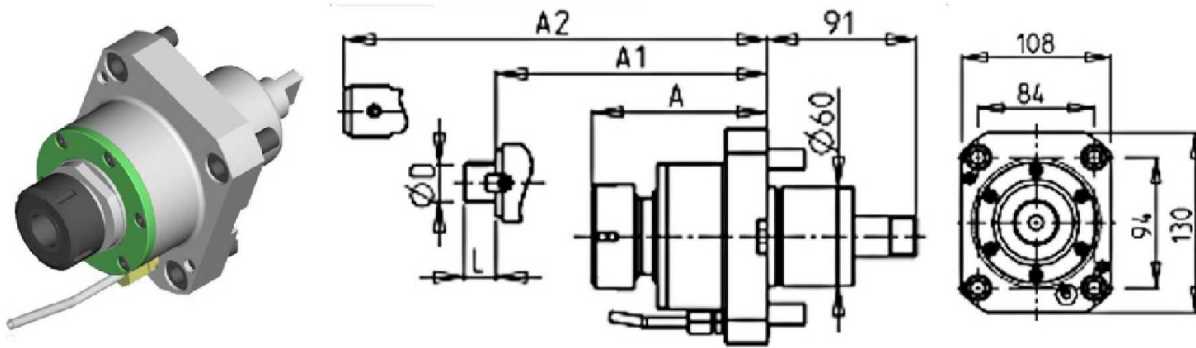

PartNumber	Description	Spindle	I	RPM	Cool Thru	Ext Cool	A	A1	A2	D	L
MNL0020532	Radial ER32 Standard	ER32	1:1	6000		X	104.16				
MNL0021532	Radial ER32 Cool Thru*	ER32	1:1	6000	X	X	104.16				
MNL0020732	Radial ER32 Cool Thru*	ER32	1:1	6000	X		107.66				
MNL0022132	Radial ER32 Short	ER32 Short	1:1	6000		X	75.76				
MNL0020632	Radial ER32 Extended Reach	ER32	1:1	6000		X	144.16				
MNL0021632	Radial ER32 Ext. Reach Cool Thru*	ER32	1:1	6000	X	X	144.16				
MNL0020140	Radial ER40 Standard	ER40	1:1	6000		X	106.66				
MNL0021140	Radial ER40 Cool Thru*	ER40	1:1	6000	X	X	106.66				
MNL0022140	Radial ER40 Short	ER40 Short	1:1	6000		X	89.66				
MNL0021617	Radial Mill Head 16x17mm	16x17	1:1	6000		X		116		16	17
MNL0020116	Radial Mill Head 16x17mm Cool Thru*	16x17	1:1	6000	X	X		116		16	17
MNL0022219	Radial Mill Head 22x19mm	22x19	1:1	6000		X		106		22	19
MNL0020122	Radial Mill Head 22x19mm Cool Thru*	22x19	1:1	6000	X	X		106		22	19
MNL0022721	Radial Mill Head 27x21mm	27x21	1:1	6000		X		81.5		27	21
MNL0022519	Radial Mill Head 1"x19mm	1"x19	1:1	6000		X		81.5		1"	21
MNL0020525	Radial Mill Head 1"x19mm Cool Thru*	1"x19	1:1	6000	X	X		84.5		1"	21
MNL0020120	Radial Weldon 20	Weldon 20	1:1	6000		X				99.5	
MNL0020220	Radial Weldon 20 Cool Thru*	Weldon 20	1:1	6000	X	X				99.5	
MNL0020125	Radial Weldon 25	Weldon 25	1:1	6000		X				109	
MNL0020425	Radial Weldon 25 Cool Thru*	Weldon 25	1:1	6000	X	X				109	
MNL0020132	Radial Weldon 32	Weldon 32	1:1	6000		X				125.5	
MNL0020232	Radial Weldon 32 Cool Thru*	Weldon 32	1:1	6000	X	X				125.5	

*Coolant Thru tools are designed for 400 psi MAX.
They require 5 Micron Filtration and **CANNOT** be run dry.

DRIVEN

TS3000/4000/5000 Y/YS 12 ST. (3 KEYS TURRET)

QUICK CHANGE RADIAL MTSK DRIVEN TOOL

Please see Accessories for MTSK Clamping Units

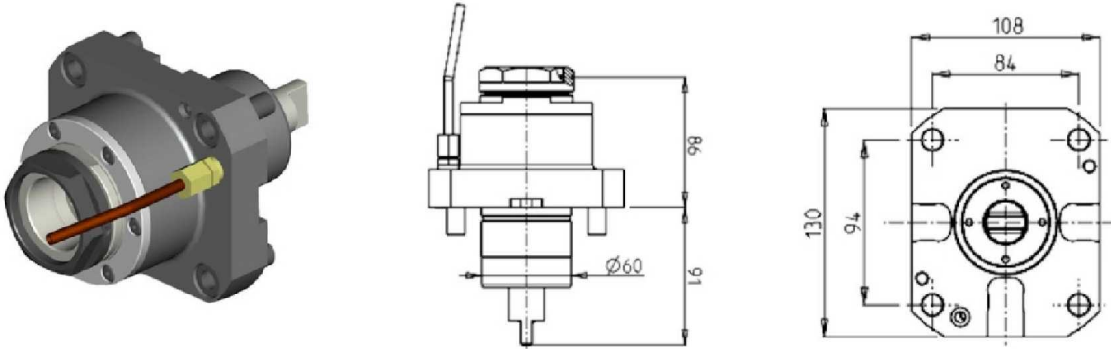

PartNumber	Description	Spindle	I	RPM	Ext Cool
MNL0590150	Radial MTSK-50	MTSK-50	1:1	6000	X

RADIAL DRIVEN TOOL HIGH PRESSURE

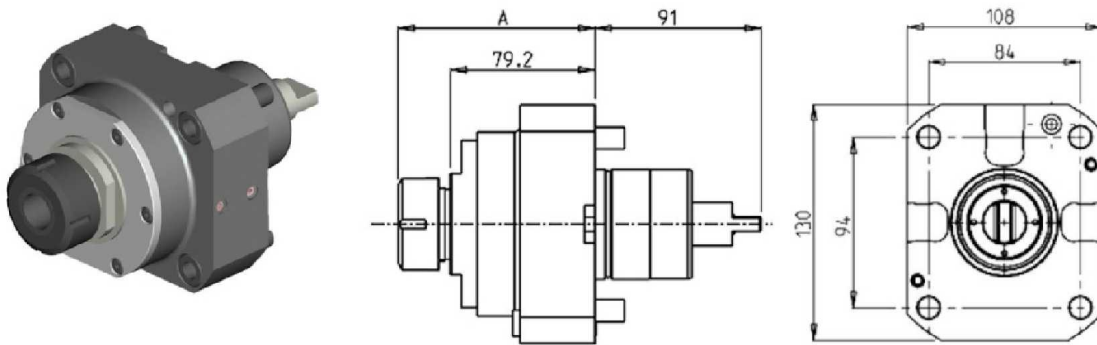

PartNumber	Description	Spindle	I	RPM	Cool Thru	Ext Cool	A
MNL0570125	Radial ER25 Cool Thru*	ER25	1:1	6000	X	X	104.8
MNL0570132	Radial ER32 Cool Thru*	ER32	1:1	6000	X	X	107.8

* Coolant Thru tools are designed for 1100 psi.
They require 5 Micron Filtration and **CANNOT** be run dry.

DRIVEN

TS3000/4000/5000 Y/YS 12 ST. (3 KEYS TURRET)

QUICK CHANGE RADIAL MTSK DRIVEN TOOL HIGH PRESSURE

Please see Accessories for MTSK Clamping Units

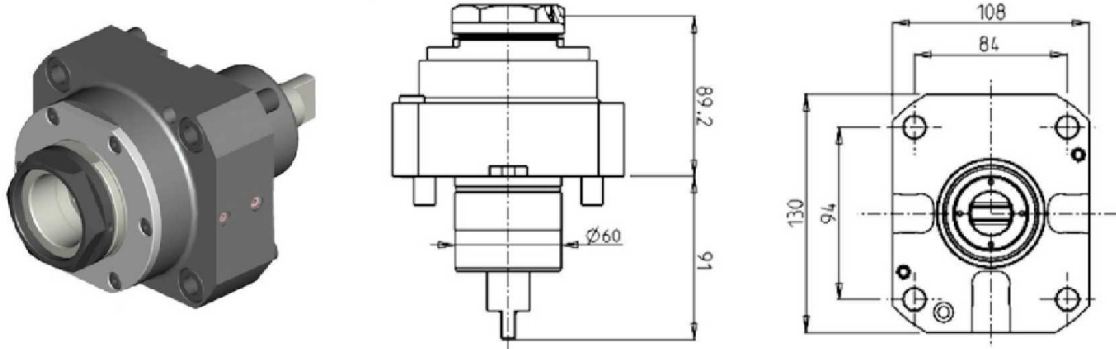

PartNumber	Description	Spindle	I	RPM	Cool Thru	Ext Cool
MNL0590250	Radial MTSK-50 Cool Thru*	MTSK-50	1:1	6000	X	X

* Coolant Thru tools are designed for 1100 psi.
They require 5 Micron Filtration and **CANNOT** be run dry.

RADIAL REINFORCED MILLING TOOL

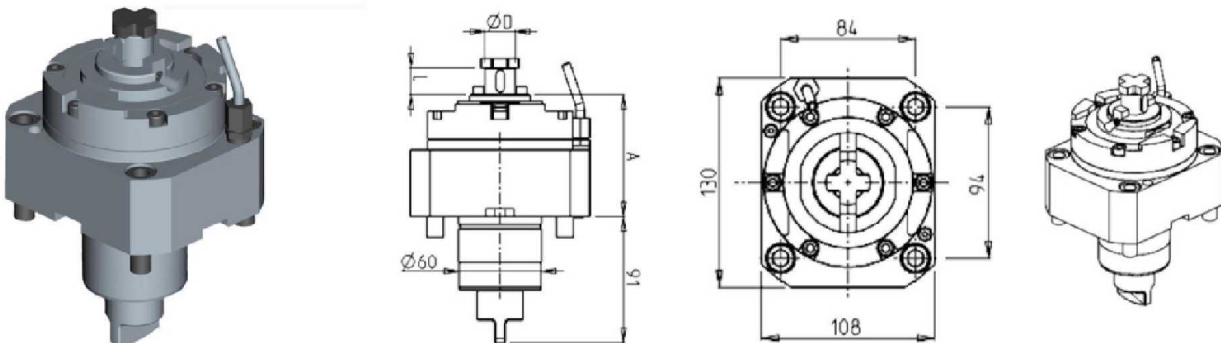

PartNumber	Description	Spindle	I	RPM	Ext Cool	A	D	L
MNL0732519	Radial Reinforced Driven Tool 1"x19mm	1"x19	1:1	4000	X	89	1"	19
MNL0732219	Radial Reinforced Driven Tool 22x19mm	22x19	1:1	4000	X	88	22	19
MNL0732721	Radial Reinforced Driven Tool 27x21mm	27x21	1:1	4000	X	89	27	21
MNL0733224	Radial Reinforced Driven Tool 32x24mm	32x24	1:1	4000	X	91	32	24

DRIVEN

TS3000/4000/5000 Y/YS 12 ST. (3 KEYS TURRET)

QUICK CHANGE RADIAL MTSK REINFORCED DRIVEN TOOL

Please see Accessories for MTSK Clamping Units

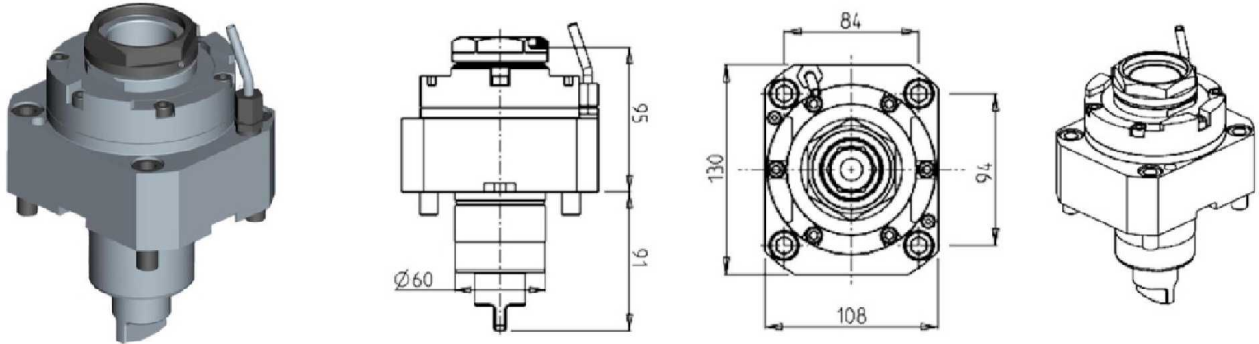

PartNumber	Description	Spindle	I	RPM	Ext Cool
MNL0740150	Radial MTSK-50 Reinforced	MTSK-50	1:1	4000	X

RADIAL DRIVEN TOOL REDIRECTED IN Z BY 45mm

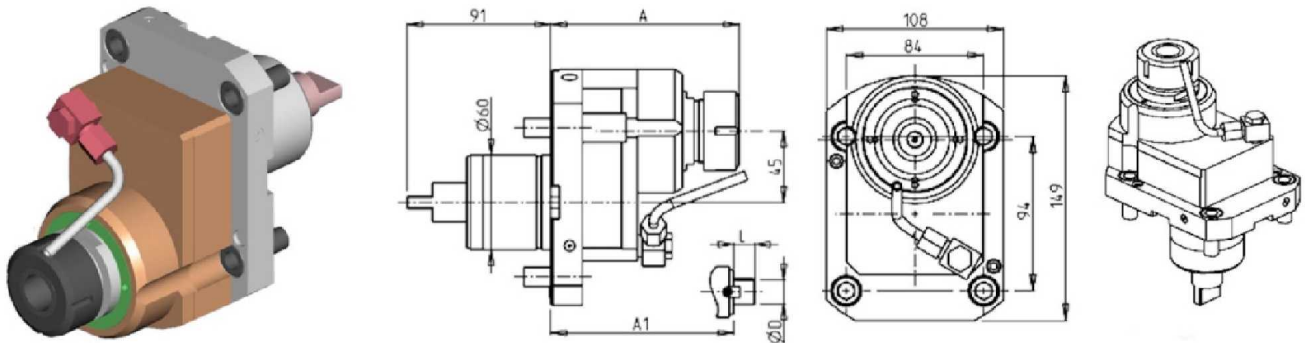

PartNumber	Description	Spindle	I	RPM	Reversible	Cool Thru	Ext Cool	A	A1	D	L
MNL0340120	Radial Redirected ER20	ER20	1:1	6000	X		X	115.66			
MNL0340220	Radial Redirected ER20 Cool Thru*	ER20	1:1	6000	X	X	X	126.66			
MNL0340032	Radial Redirected ER32	ER32	1:1	6000	X		X	119.66			
MNL0340132	Radial Redirected ER32 Cool Thru*	ER32	1:1	6000	X	X	X	131.16			
MNL0341119	Radial Redirected Mill Head 3/4"x3/4"	3/4"x3/4"	1:1	6000	X		X		98	3/4"	3/4"
MNL0342225	Radial Redirected Mill Head 1"x19mm	1"x19	1:1	6000	X		X		98	1"	19
MNL0341116	Radial Redirected Mill Head 16x17mm	16x17	1:1	6000	X		X		98	16	17
MNL0341122	Radial Redirected Mill Head 22x19mm	22x19	1:1	6000	X		X		98	22	19
MNL0341127	Radial Redirected Mill Head 27x21mm	27x21	1:1	6000	X		X		98	27	21

* Coolant Thru tools are designed for 1000 psi.
They require 5 Micron Filtration and **CANNOT** be run dry.

DRIVEN

TS3000/4000/5000 Y/YS 12 ST. (3 KEYS TURRET)

QUICK CHANGE RADIAL MTSK DRIVEN TOOL REDIRECTED IN Z BY 45mm

Please see Accessories for MTSK Clamping Units

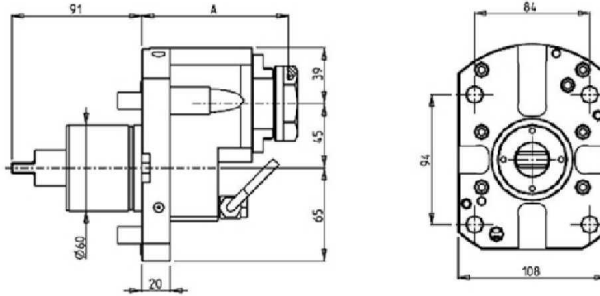
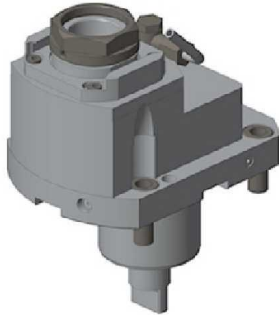

PartNumber	Description	Spindle	I	RPM	Reversible	Cool Thru	Ext Cool	A
MNL1210140	Radial Redirected MTSK-40	MTSK-40	1:1	6000	X		X	103
MNL1210240	Radial Redirected MTSK-40 Cool Thru*	MTSK-40	1:1	6000	X	X	X	114

* Coolant Thru tools are designed for 1000 psi. They require 5 Micron Filtration and **CANNOT** be run dry.

RADIAL GEARED-DOWN 2:1 DRIVEN TOOL REDIRECTED IN Z BY 45mm

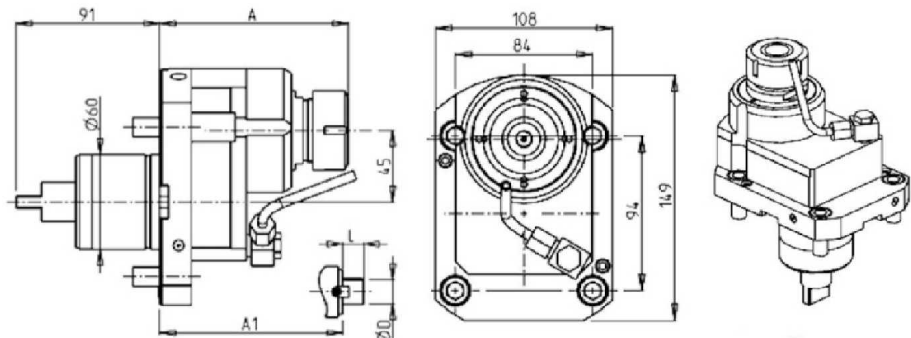
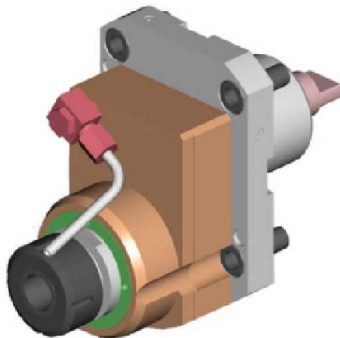

PartNumber	Description	Spindle	Reversible	I	RPM	Ext Cool	A	A1	D	L
MNL0342132	Radial Geared-Down 2:1 ER32	ER32	X	2:1	3000	X	119.66			
MNL0342119	Radial Geared-Down 2:1 Mill Head 3/4"x3/4"	3/4"x3/4"	X	2:1	3000	X	98	3/4"	3/4"	
MNL0342125	Radial Geared-Down 2:1 Mill Head 1"x19mm	1"x19	X	2:1	3000	X	98	1"	19	
MNL0342122	Radial Geared-Down 2:1 Mill Head 22x19mm	22x19	X	2:1	3000	X	98	22	19	
MNL0342127	Radial Geared-Down 2:1 Mill Head 27x21mm	27x21	X	2:1	3000	X	98	27	21	

DRIVEN

TS3000/4000/5000 Y/YS 12 ST. (3 KEYS TURRET)

QUICK CHANGE RADIAL MTSK GEARED-DOWN 2:1 DRIVEN TOOL REDIRECTED IN Z BY 45mm

Please see Accessories for MTSK Clamping Units

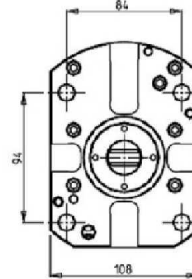
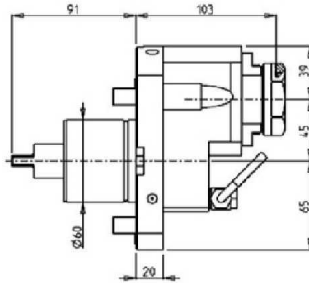
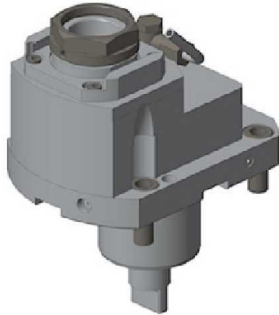

PartNumber	Description	Spindle	I	RPM	Reversible	Ext Cool
MNL1220140	Radial Geared-Down 2:1 Redirected MTSK-40	MTSK-40	2:1	3000	X	X

RADIAL GEARED-UP 1:2 DRIVEN TOOL REDIRECTED IN Z BY 45mm

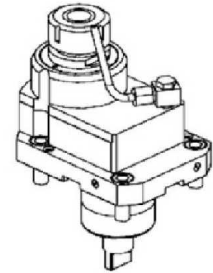
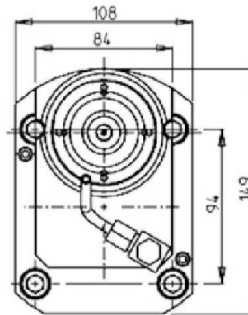
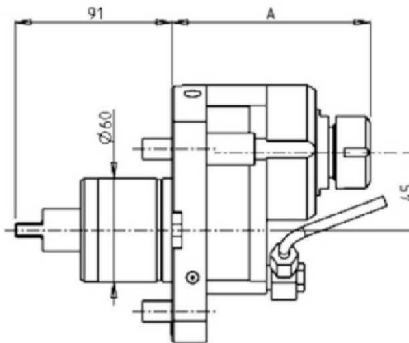
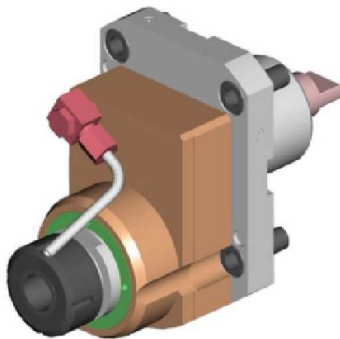

PartNumber	Description	Spindle	Reversible	I	RPM	Cool Thru	Ext Cool	A
MNL0341225	Radial Redirected ER25 Geared-Up 1:2	ER25	X	1:2	12000		X	115.16
MNL0342425	Radial Redirected ER25 Geared-Up 1:2 Cool Thru*	ER25	X	1:2	12000	X	X	126.16

* Coolant Thru tools are designed for 1000 psi. They require 5 Micron Filtration and **CANNOT** be run dry.

DRIVEN

TS3000/4000/5000 Y/YS 12 ST. (3 KEYS TURRET)

RADIAL GEARED-UP 1:5 DRIVEN TOOL

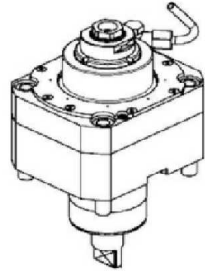
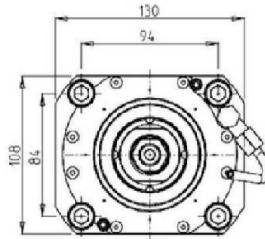
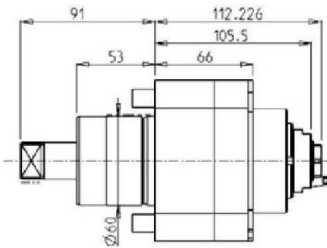
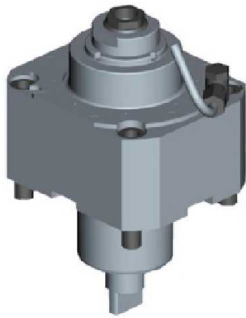

PartNumber	Description	Spindle	I	RPM	Ext Cool
MNL0690120	Radial Geared-Up 1:5 Driven Tool ERA20	ERA20	1:5	30000	X

Note : Wrenches are provided with the purchase of Specialty Toolholders

DRIVEN

TS3000/4000/5000 Y/YS 12 ST. (3 KEYS TURRET)

RADIAL SINGLE SIDE TWIN HEAD DRIVEN TOOL FOR Y-AXIS

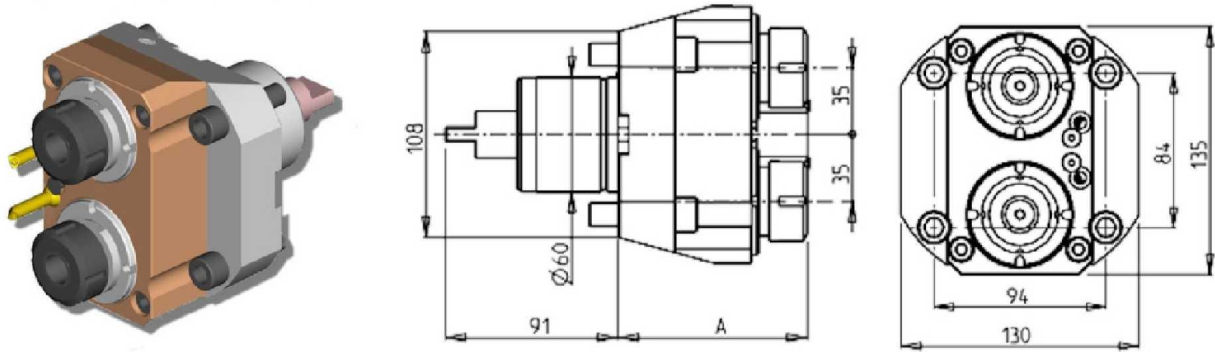

PartNumber	Description	Spindle	I	RPM	Cool Thru	Ext Cool	A
MNL0200225	Radial Single Side Twin Driven Tool ER25	ER25	1:1	6000		X	99.96
MNL0201225	Radial Single Side Twin Driven Tool ER25 Cool Thru*	ER25	1:1	6000	X	X	115.2
MNL0201325	Radial Single Side Twin Driven Tool ERA25 Cool Thru*	ERA25	1:1	6000	X	X	108.53

* Coolant Thru tools are designed for 1000 psi. They require 5 Micron Filtration and **CANNOT** be run dry.

RADIAL SINGLE SIDE TWIN HEAD DRIVEN TOOL FOR Z-AXIS

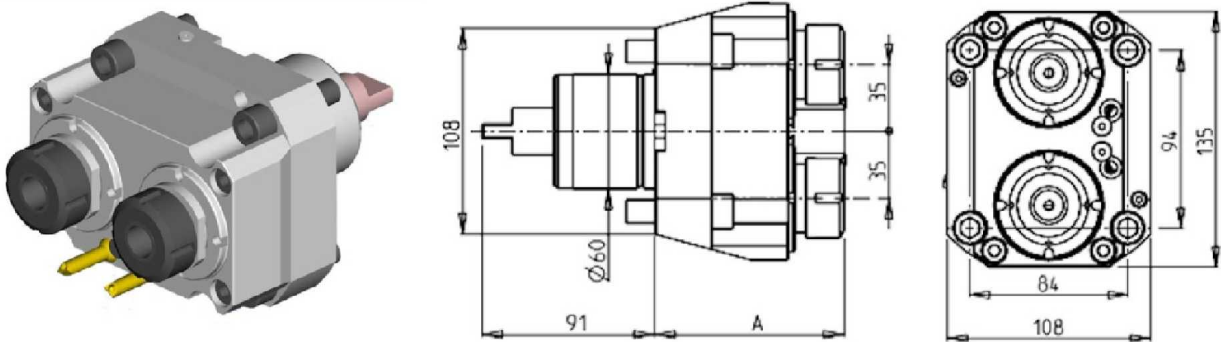

PartNumber	Description	Spindle	I	RPM	Cool Thru	Ext Cool	A
MNL0420225	Radial ER25 Double Outlet Tool for Z-Axis	ER25	1:1	6000		X	99.96
MNL0421225	Radial ER25 Double Outlet Tool for Z-Axis Cool Thru*	ER25	1:1	6000	X	X	115.2
MNL0421325	Radial ERA25 Double Outlet Tool for Z-Axis Cool Thru*	ERA25	1:1	6000	X	X	108.53

* Coolant Thru tools are designed for 1000 psi. They require 5 Micron Filtration and **CANNOT** be run dry.

DRIVEN

TS3000/4000/5000 Y/YS 12 ST. (3 KEYS TURRET)

RADIAL 6 HEAD DRIVEN TOOL

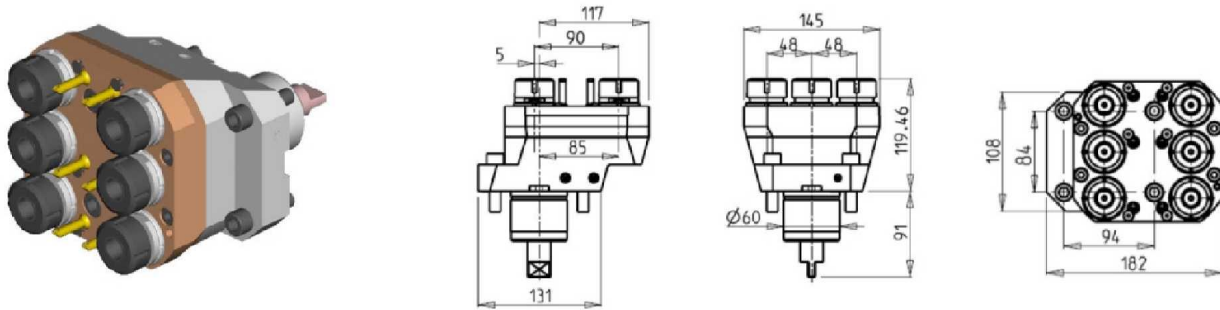

PartNumber	Description	Spindle	I	RPM	# of Tools	Reversible	Ext Cool
MNL0210625	Radial 6 Head Driven Tool ER25	ER25	1:1	6000	6	X	X

Note : Wrenches are provided with the purchase of Specialty Toolholders

RADIAL INVERTED DRIVEN TOOL REDIRECTED IN Z

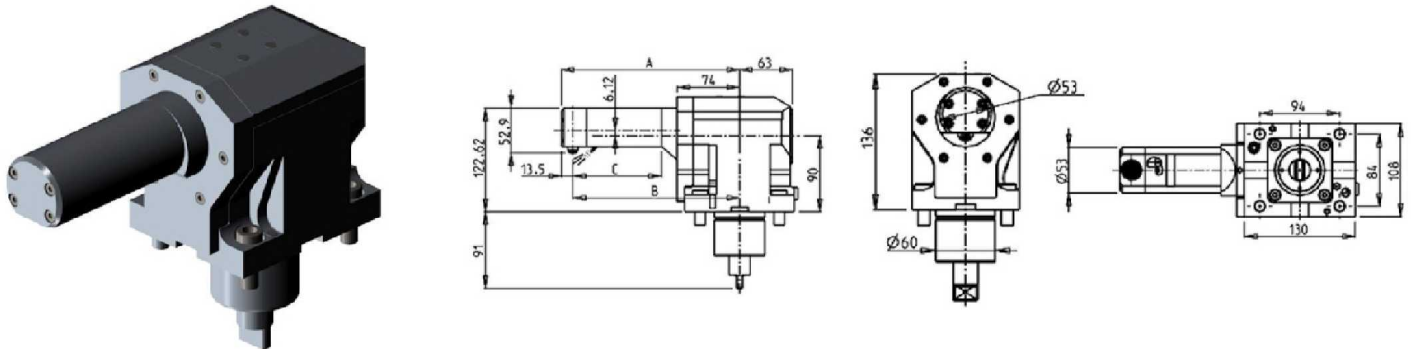

PartNumber	Description	Spindle	I	RPM	Ext Cool	A	B	C
MNL0961055	Radial Inverted Driven Tool	CHG	1:1	6000	X	161.5	148	55
MNL0961105	Radial Inverted Driven Tool	CHG	1:1	6000	X	211.5	198	105
MNL0961155	Radial Inverted Driven Tool	CHG	1:1	6000	X	261.5	248	155

Note : Wrenches are provided with the purchase of Specialty Toolholders

DRIVEN

TS3000/4000/5000 Y/YS 12 ST. (3 KEYS TURRET)

RADIAL ±25° ADJUSTABLE ANGLE DRIVEN TOOL REDIRECTED BY 50mm

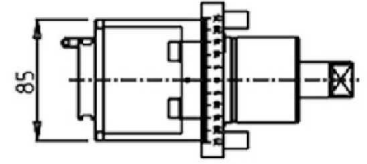
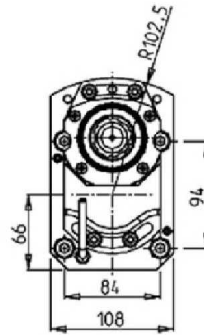
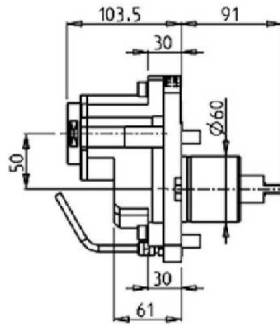
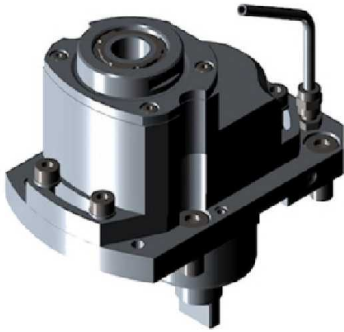

PartNumber	Description	Spindle	I	RPM	Reversible	Ext Cool
MNL0950332	Radial ±25° Adjustable Angle ERA32	ERA32	1:1	6000	X	X

DRIVEN

TS3000/4000/5000 Y/YS 12 ST. (3 KEYS TURRET)

AXIAL DRIVEN TOOL

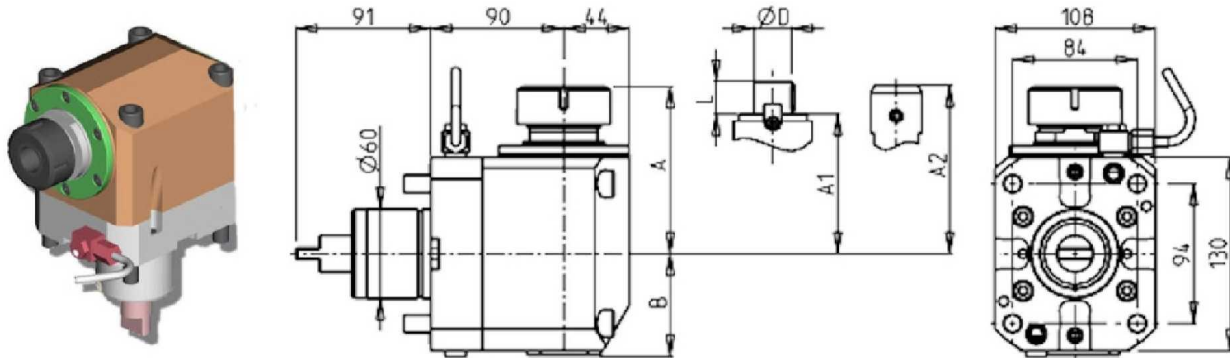

PartNumber	Description	Spindle	Reversible	I	RPM	Cool Thru	Ext Cool	A	A1	A2	B	D	L
MNL0010525	Axial ER25	ER25	X	1:1	6000		X	107.6			69		
MNL0011525	Axial ER25 Cool Thru*	ER25	X	1:1	6000	X	X	107.6			79		
MNL0010532	Axial ER32	ER32	X	1:1	6000		X	110.6			69		
MNL0011532	Axial ER32 Cool Thru*	ER32	X	1:1	6000	X	X	110.6			79		
MNL0010332	Axial ERA32	ERA32	X	1:1	6000		X	98.5			69		
MNL0010432	Axial ERA32 Cool Thru*	ERA32	X	1:1	6000	X	X	98.5			79		
MNL0010140	Axial ER40	ER40	X	1:1	6000		X	112.6			69		
MNL0011140	Axial ER40 Cool Thru*	ER40	X	1:1	6000	X	X	112.6			79		
MNL0011617	Axial Mill Head 16x17mm	16x17	X	1:1	6000		X		87.5		69	16	17
MNL0012219	Axial Mill Head 22x19mm	22x19	X	1:1	6000		X		87.5		69	22	19
MNL0012721	Axial Mill Head 27x21mm	27x21	X	1:1	6000		X		87.5		69	27	21
MNL0012519	Axial Mill Head 1"x19mm	1"x19	X	1:1	6000		X		87.5		69	1"	19
MNL0010120	Axial Weldon 20	Weldon 20	X	1:1	6000		X			105.5	69		
MNL0010220	Axial Weldon 20 Cool Thru*	Weldon 20	X	1:1	6000	X	X			105.5	91.5		
MNL0010125	Axial Weldon 25	Weldon 25	X	1:1	6000		X			115	69		
MNL0010225	Axial Weldon 25 Cool Thru*	Weldon 25	X	1:1	6000	X	X			115	91.5		
MNL0010132	Axial Weldon 32	Weldon 32	X	1:1	6000		X			131.5	69		

* Coolant Thru tools are designed for 1000 psi.
They require 5 Micron Filtration and **CANNOT** be run dry.

DRIVEN

TS3000/4000/5000 Y/YS 12 ST. (3 KEYS TURRET)

QUICK CHANGE AXIAL MTSK DRIVEN TOOL

Please see Accessories for MTSK Clamping Units

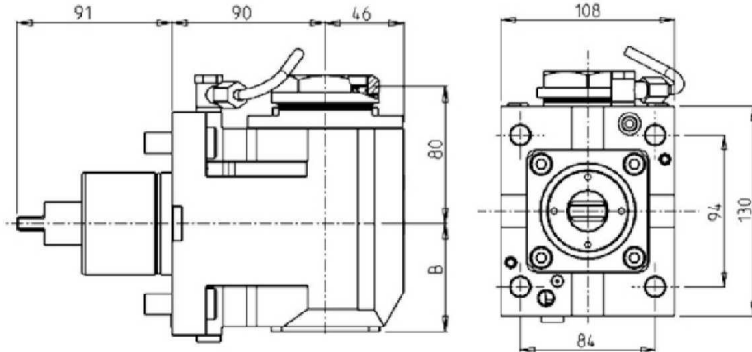

PartNumber	Description	Spindle	Reversible	I	RPM	Cool Thru	Ext Cool	B
MNL0580140	Axial MTSK-40	MTSK-40	X	1:1	6000		X	63
MNL0580240	Axial MTSK-40 Cool Thru*	MTSK-40	X	1:1	6000	X	X	75.5
MNL0580150	Axial MTSK-50	MTSK-50	X	1:1	6000		X	63
MNL0580250	Axial MTSK-50 Cool Thru*	MTSK-50	X	1:1	6000	X	X	75.5

* Coolant Thru tools are designed for 1000 psi.
They require 5 Micron Filtration and **CANNOT** be run dry.

AXIAL REAR-SET DRIVEN TOOL

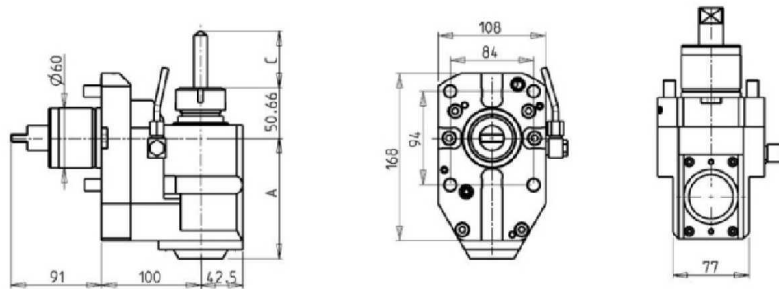

PartNumber	Description	Spindle	Reversible	I	RPM	Cool Thru	Ext Cool	A	CMax
MNL0290632	Axial ER32 Rear-Set Driven Tool	ER32	X	1:1	6000		X	121	118
MNL0291632	Axial ER32 Rear-Set Driven Tool Cool Thru*	ER32	X	1:1	6000	X	X	135	118

* Coolant Thru tools are designed for 1000 psi.
They require 5 Micron Filtration and **CANNOT** be run dry.

DRIVEN

TS3000/4000/5000 Y/YS 12 ST. (3 KEYS TURRET)

AXIAL DRIVEN TOOL

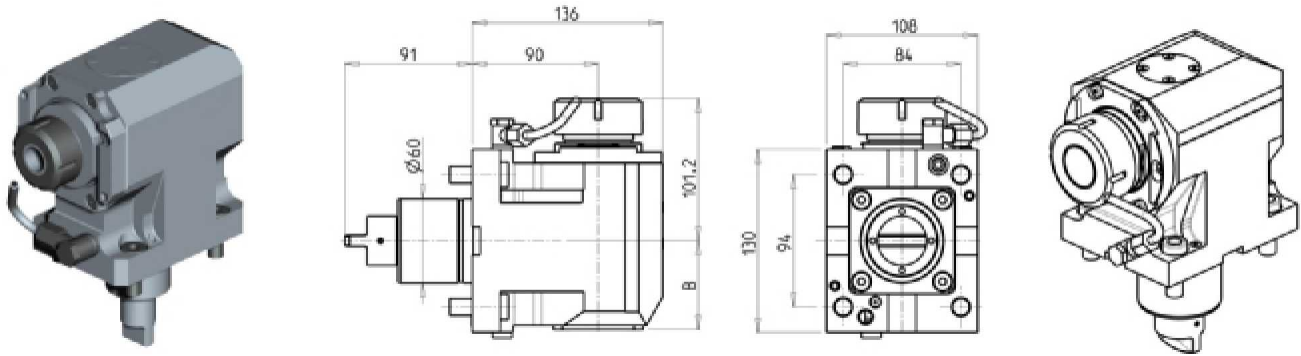

PartNumber	Description	Spindle	I	RPM	Reversible	Cool Thru	Ext Cool	B
MNL0840140	Axial ER40	ER40	1:1	4000	X		X	63
MNL0840240	Axial ER40 Cool Thru*	ER40	1:1	4000	X	X	X	75.5

* Coolant Thru tools are designed for 1000 psi.
They require 5 Micron Filtration and **CANNOT** be run dry.

QUICK CHANGE AXIAL MTSK DRIVEN TOOL

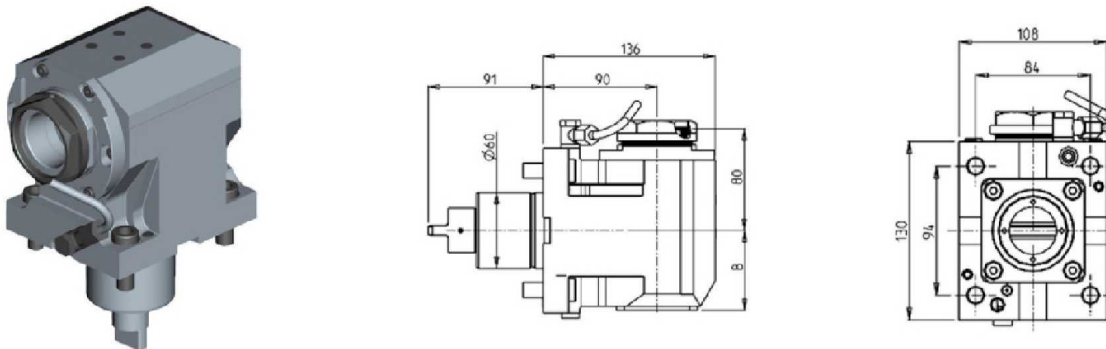

PartNumber	Description	Spindle	I	RPM	Reversible	Cool Thru	Ext Cool	B
MNL0850140	Axial MTSK-40	MTSK-40	1:1	4000	X		X	63
MNL0850240	Axial MTSK-40 Cool Thru*	MTSK-40	1:1	4000	X	X	X	75.5
MNL0850150	Axial MTSK-50	MTSK-50	1:1	4000	X		X	63
MNL0850250	Axial MTSK-50 Cool Thru*	MTSK-50	1:1	4000	X	X	X	75.5

* Coolant Thru tools are designed for 1000 psi.
They require 5 Micron Filtration and **CANNOT** be run dry.

DRIVEN

TS3000/4000/5000 Y/YS 12 ST. (3 KEYS TURRET)

AXIAL GEARED-DOWN 2:1 DRIVEN TOOL

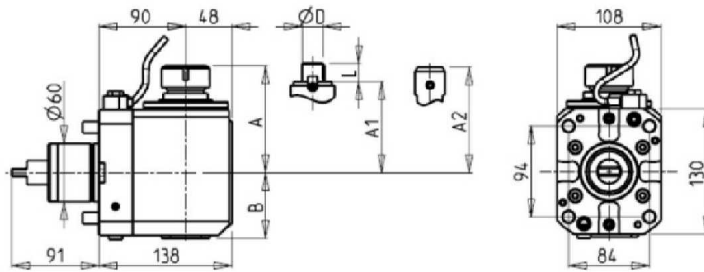
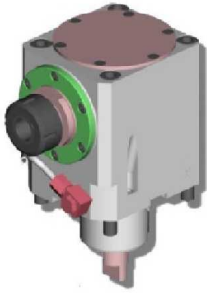

PartNumber	Description	Spindle	Reversible	I	RPM	Cool Thru	Ext Cool	A	A1	A2	B	D	L
MNL0330525	Axial Geared-Down 2:1 ER25	ER25	X	2:1	3000		X	107.5			68		
MNL0331525	Axial Geared-Down 2:1 ER25 Cool Thru*	ER25	X	2:1	3000	X	X	107.5			79		
MNL0330532	Axial Geared-Down 2:1 ER32	ER32	X	2:1	3000		X	110.56			68		
MNL0331532	Axial Geared-Down 2:1 ER32 Cool Thru*	ER32	X	2:1	3000	X	X	110.56			79		
MNL0330140	Axial Geared-Down 2:1 ER40	ER40	X	2:1	3000		X	113.16			68		
MNL0331140	Axial Geared-Down 2:1 ER40 Cool Thru*	ER40	X	2:1	3000	X	X	113.16			79		
MNL0331617	Axial Geared-Down 2:1 Mill Head 16x17mm	16x17	X	2:1	3000		X	87.5			68	16	17
MNL0332219	Axial Geared-Down 2:1 Mill Head 22x19mm	22x19	X	2:1	3000		X	87.5			68	22	19
MNL0332721	Axial Geared-Down 2:1 Mill Head 27x21mm	27x21	X	2:1	3000		X	87.5			68	27	21
MNL0332519	Axial Geared-Down 2:1 Mill Head 1"x19mm	1"x19	X	2:1	3000		X	87.5			68	1"	19
MNL0330120	Axial Geared-Down 2:1 Weldon20	Weldon 20	X	2:1	3000		X				105.5	68	
MNL0330220	Axial Geared-Down 2:1 Weldon20 Cool Thru*	Weldon 20	X	2:1	3000	X	X				105.5	91.5	
MNL0330125	Axial Geared-Down 2:1 Weldon25	Weldon 25	X	2:1	3000		X				115	68	
MNL0330225	Axial Geared-Down 2:1 Weldon25 Cool Thru*	Weldon 25	X	2:1	3000	X	X				115	91.5	
MNL0330132	Axial Geared-Down 2:1 Weldon32	Weldon 32	X	2:1	3000		X				131.5	68	
MNL0330232	Axial Geared-Down 2:1 Weldon32 Cool Thru*	Weldon 32	X	2:1	3000	X	X				131.5	91.5	

* Coolant Thru tools are designed for 1000 psi.
They require 5 Micron Filtration and **CANNOT** be run dry.

AXIAL GEARED-UP 1:2 DRIVEN TOOL

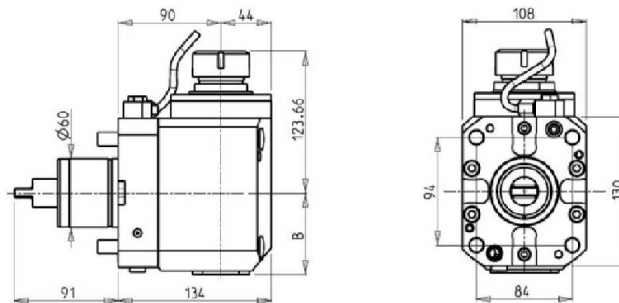

PartNumber	Description	Spindle	Reversible	I	RPM	Cool Thru	Ext Cool	B
MNL0350532	Axial ER32 Geared-Up 1:2	ER32	X	1:2	12000		X	71
MNL0351532	Axial ER32 Geared-Up 1:2 Cool Thru*	ER32	X	1:2	12000	X	X	94.5

DRIVEN

TS3000/4000/5000 Y/YS 12 ST. (3 KEYS TURRET)

AXIAL GEARED-UP 1:2 DRIVEN TOOL

* Coolant Thru tools are designed for 1000 psi.
They require 5 Micron Filtration and **CANNOT** be run dry.

AXIAL MTSK DRIVEN TOOL FOR INTERNAL POLYGON-MAKING H=90mm

Please see Accessories for MTSK Clamping Units

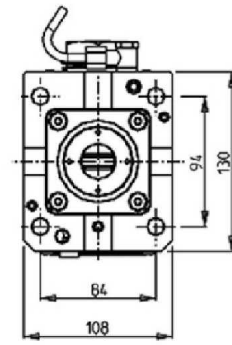
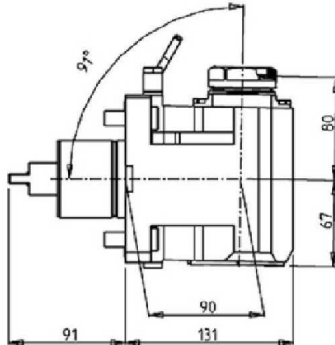

PartNumber	Description	Spindle	I	RPM	Reversible	Ext Cool
MNL0900140	Axial MTSK-40 Driven Tool H=90mm	MTSK-40	1:1	6000	X	X

AXIAL SINGLE SIDE TWIN HEAD DRIVEN TOOL IN Y FOR INTERNAL POLYGON-MAKING H=90mm

See Accessories for Polygon Making Mill Heads

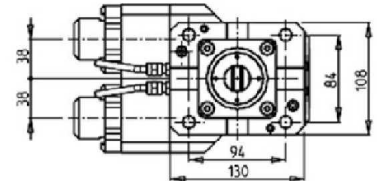
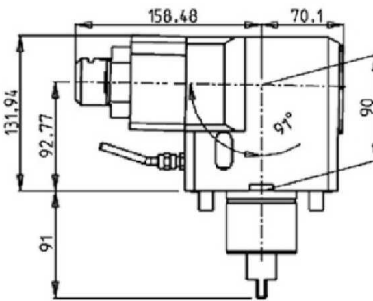
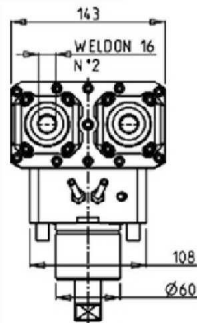

PartNumber	Description	Spindle	I	RPM	Reversible	Ext Cool
MNL0940616	Axial Single Side Twin Head Weldon 16	Weldon 16	1:1	6000	X	X

Note : Wrenches are provided with the purchase of Specialty Toolholders

DRIVEN

TS3000/4000/5000 Y/YS 12 ST. (3 KEYS TURRET)

AXIAL OPPOSITE FACE TWIN DRIVEN TOOL

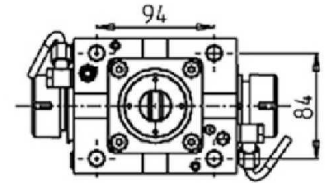
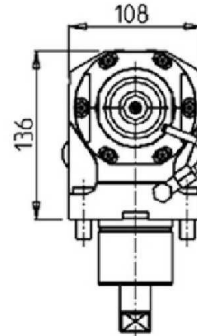
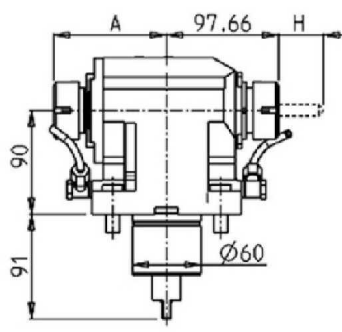

PartNumber	Description	Spindle	I	RPM	Reversible	Ext Cool	A
MNL0830232	Axial Double Outlet ER32/ER32	ER32+ER32	1:1	6000	X	X	98.7
MNL0830240	Axial Double Outlet ER40/ER32	ER40+ER32	1:1	6000	X	X	101.7

QUICK CHANGE AXIAL MTSK OPPOSITE FACE TWIN DRIVEN TOOL

Please see Accessories for MTSK Clamping Units

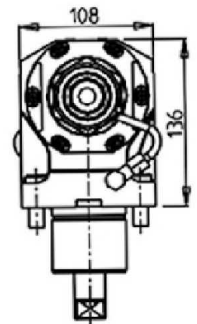
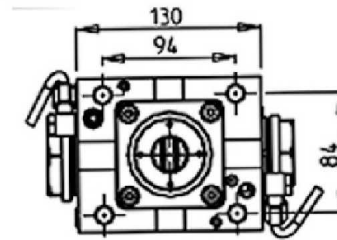
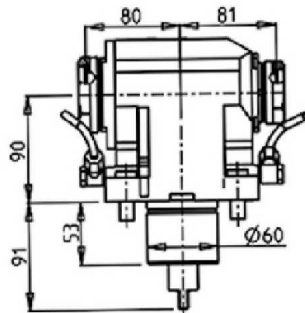
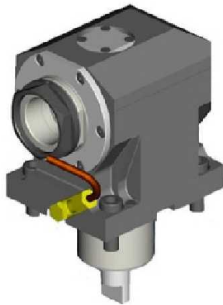

PartNumber	Description	Spindle	I	RPM	Reversible	Ext Cool
MNL1015040	Axial MTSK Opposite Face Twin Driven Tool	MTSK50+MTSK40	1:1	6000	X	X

AXIAL GEARED-DOWN 2:1 OPPOSITE FACE TWIN DRIVEN TOOL

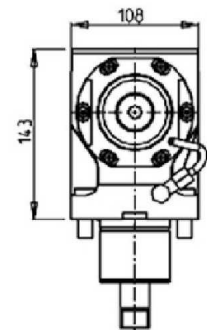
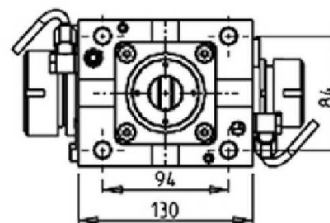
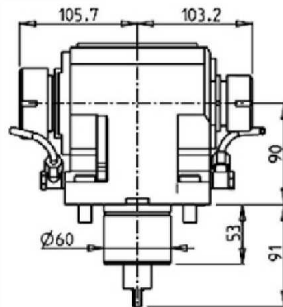
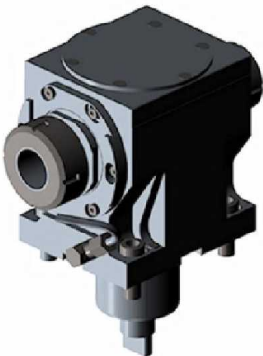

PartNumber	Description	Spindle	I	RPM	Reversible	Ext Cool
MNL0914032	Axial Geared-Down 2:1 Opposite Face ER40+ER32	ER40+ER32	2:1	3000	X	X

DRIVEN

TS3000/4000/5000 Y/YS 12 ST. (3 KEYS TURRET)

AXIAL GEARED-UP 1:2 OPPOSITE FACE TWIN DRIVEN TOOL

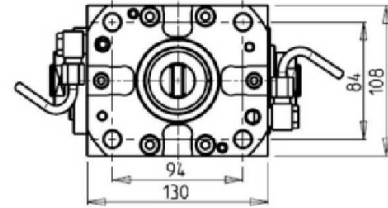
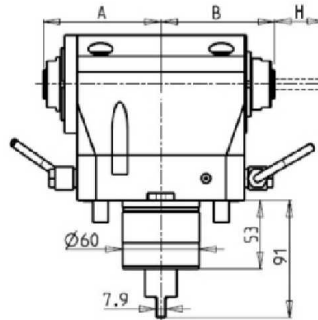
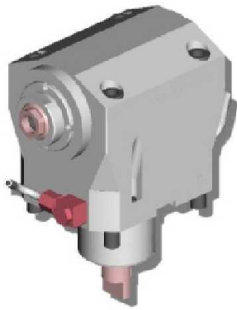

PartNumber	Description	Spindle	I	RPM	Reversible	Ext Cool	A	B	H Max
MNL0450116	Axial Geared-Up 1:2 Opposite Face ERA16+ERA16	ERA16+ERA16	1:2	12000	X	X	97.63	94.13	77.6
MNL0450120	Axial Geared-Up 1:2 Opposite Face ERA20+ERA20	ERA20+ERA20	1:2	12000	X	X	95.73	93.73	78

DRIVEN

TS3000/4000/5000 Y/YS 12 ST. (3 KEYS TURRET)

AXIAL SINGLE SIDE TWIN HEAD DRIVEN TOOL IN Y

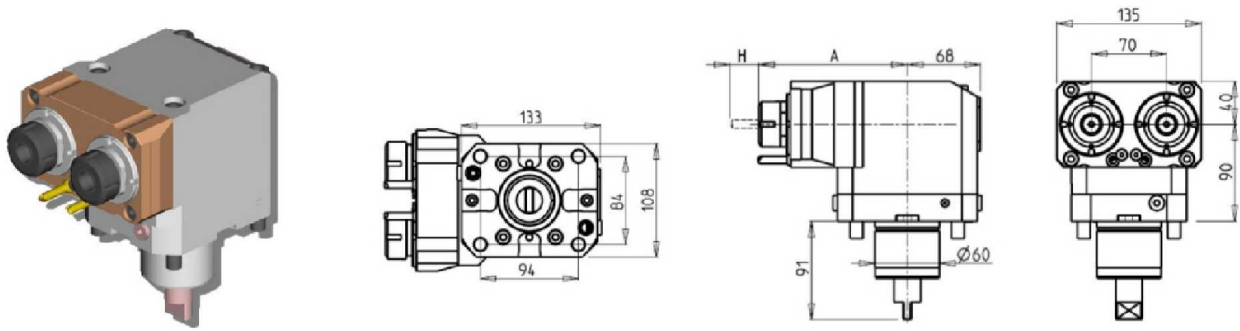

PartNumber	Description	Spindle	Reversible	I	RPM	Cool Thru	Ext Cool	A	H Max
MNL0220225	Axial Double Outlet ER25	ER25	X	1:1	6000		X	137.96	28.5
MNL0221225	Axial Double Outlet ER25 Cool Thru*	ER25	X	1:1	6000	X	X	162.66	6.95
MNL0221325	Axial Double Outlet ERA25 Cool Thru*	ERA25	X	1:1	6000	X	X	156.03	14.5

* Coolant Thru tools are designed for 1000 psi.
They require 5 Micron Filtration and **CANNOT** be run dry.

AXIAL MULTIPLE 4/8 OUTLET HEAD DRIVEN TOOL

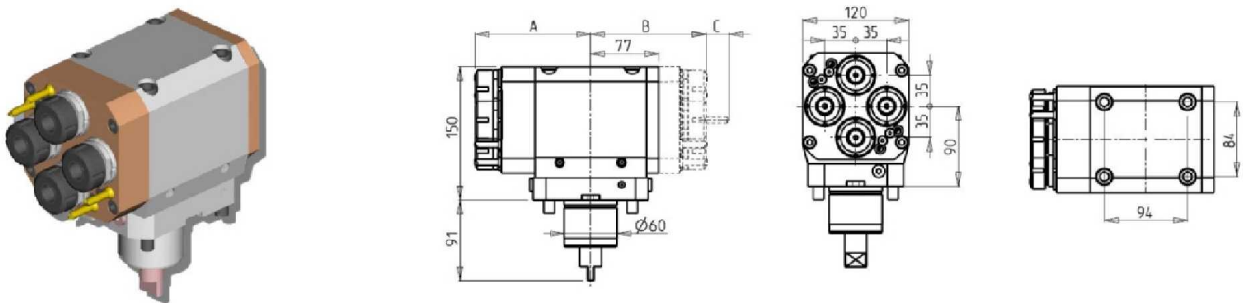

PartNumber	Description	# of Tools	Reversible	Spindle	I	RPM	Ext Cool	A	B	CMax
MNL0230425	Axial Four Outlet ER25 Tool	4	X	ER25	1:1	6000	X	130.46		
MNL0234425	Axial 4+4 Outlet ER25 Tool	4+4		ER25+ER25	1:1	6000	X	130.46	130.46	36

Note : Also available in 2+2 version : Call for price and availability. Wrenches are provided with the purchase of Specialty Toolholders.

DRIVEN

TS3000/4000/5000 Y/YS 12 ST. (3 KEYS TURRET)

0-180° ADJUSTABLE ANGLE DRIVEN TOOL

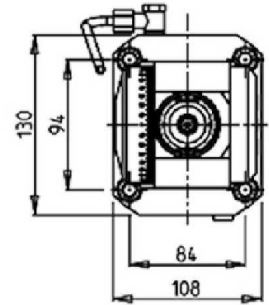
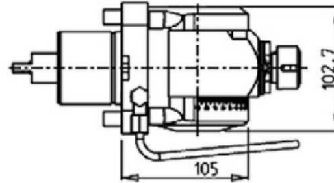
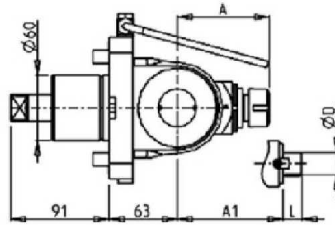

PartNumber	Description	Spindle	I	RPM	Reversible	Ext Cool	A	A1	D	L
MNL0930120	0-180° Adjustable Angle ER20	ER20	1:1	6000	X	X	85.16			
MNL0930125	0-180° Adjustable Angle ER25	ER25	1:1	6000	X	X	86.16			
MNL0930519	0-180° Adjustable Angle 3/4"x3/4"	3/4"x3/4"	1:1	6000	X	X		65	3/4"	3/4"
MNL0930516	0-180° Adjustable Angle Ø16x17mm	Ø16x17	1:1	6000	X	X		65	16	17
MNL0930522	0-180° Adjustable Angle Ø22x19mm	Ø22x19	1:1	6000	X	X		66	22	19

Note : Wrenches are provided with the purchase of Specialty Toolholders

0-180° ADJUSTABLE ANGLE DRIVEN TOOL WITH DIGITAL DISPLAY

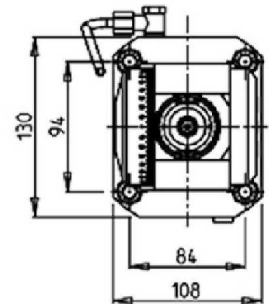
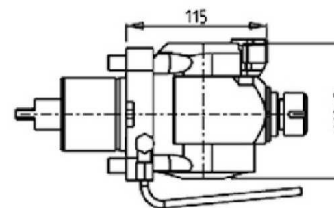
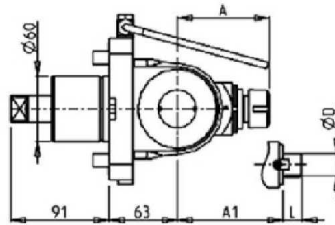

PartNumber	Description	Spindle	I	RPM	Reversible	Ext Cool	A	A1	D	L
MNL0890120	0-180° Adj. Angle with Digital Display ER20	ER20	1:1	6000	X	X	85.16			
MNL0890125	0-180° Adj. Angle with Digital Display ER25	ER25	1:1	6000	X	X	86.16			
MNL0890519	0-180° Adj. Angle with Digital Display 3/4"x3/4"	3/4"x3/4"	1:1	6000	X	X		65	3/4"	3/4"
MNL0890516	0-180° Adj. Angle with Digital Display Ø16x17mm	Ø16x17	1:1	6000	X	X		65	16	17
MNL0890522	0-180° Adj. Angle with Digital Display Ø22x19mm	Ø22x19	1:1	6000	X	X		66	22	19

Note : Wrenches are provided with the purchase of Specialty Toolholders

DRIVEN

TS3000/4000/5000 Y/YS 12 ST. (3 KEYS TURRET)

0-180° ADJUSTABLE ANGLE DRIVEN TOOL

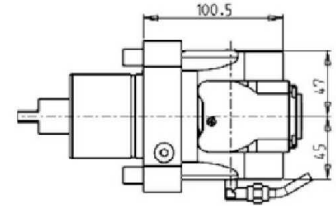
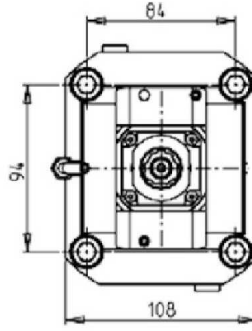
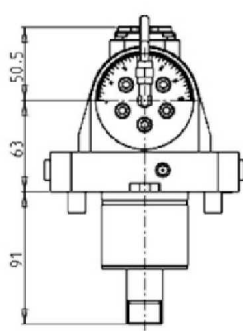
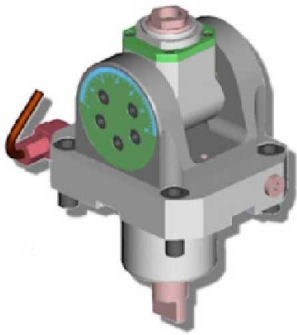

PartNumber	Description	Spindle	I	RPM	Cool Thru	Ext Cool
MNL0640120	0-180° Adjustable Angle ERA20	ERA20	1:1	6000		X
MNL0640220	0-180° Adjustable Angle ERA20 Cool Thru*	ERA20	1:1	6000	X	X

* Coolant Thru tools are designed for 1000 psi.
They require 5 Micron Filtration and **CANNOT** be run dry.

Note :

Wrenches are provided with the purchase of Specialty Toolholders

0-180° ADJUSTABLE ANGLE DRIVEN TOOL WITH DIGITAL DISPLAY

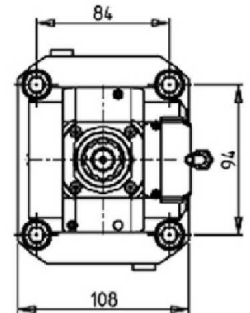
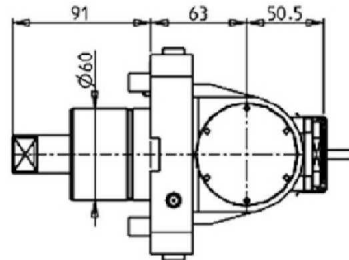
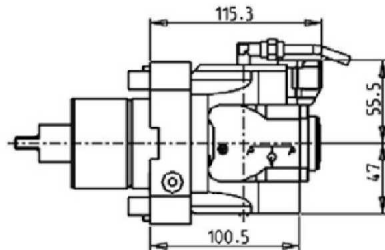

PartNumber	Description	Spindle	I	RPM	Cool Thru	Ext Cool
MNL0645120	0-180° Adj. Angle with Digital Display ERA20	ERA20	1:1	6000		X
MNL0645220	0-180° Adj. Angle with Digital Display ERA20 Cool Thru*	ERA20	1:1	6000	X	X

* Coolant Thru tools are designed for 1000 psi.
They require 5 Micron Filtration and **CANNOT** be run dry.

Note :

Wrenches are provided with the purchase of Specialty Toolholders

DRIVEN

TS3000/4000/5000 Y/YS 12 ST. (3 KEYS TURRET)

0-180° ADJUSTABLE ANGLE DRIVEN TOOL

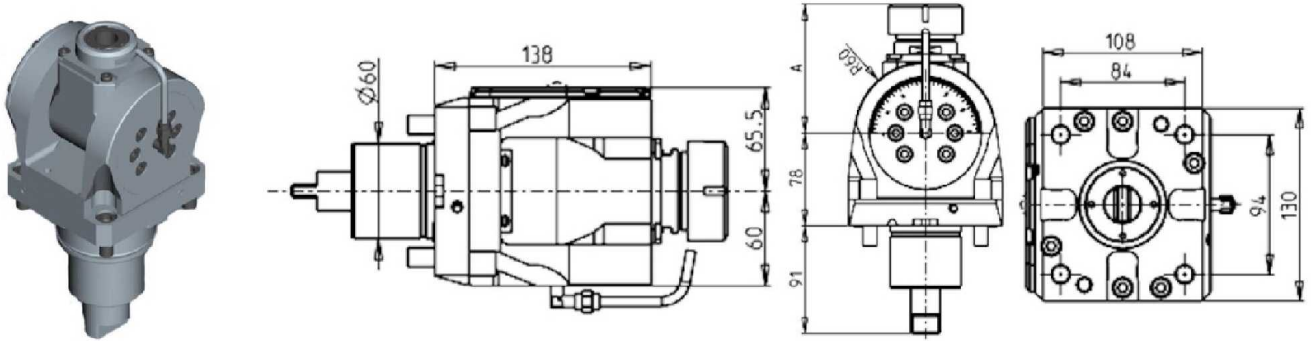

PartNumber	Description	Spindle	I	RPM	Cool Thru	Ext Cool	A
MNL0660332	0-180° Adjustable Angle ERA32	ERA32	1:1	6000		X	81
MNL0660432	0-180° Adjustable Angle ERA32 Cool Thru*	ERA32	1:1	6000	X	X	81
MNL0660140	0-180° Adjustable Angle ERA40	ER40	1:1	6000		X	108.66
MNL0660240	0-180° Adjustable Angle ERA40 Cool Thru*	ER40	1:1	6000	X	X	108.66

* Coolant Thru tools are designed for 1000 psi.
They require 5 Micron Filtration and **CANNOT** be run dry.

Note :

Wrenches are provided with the purchase of Specialty Toolholders

0-180° ADJUSTABLE ANGLE GEARED-UP 1:2 DRIVEN TOOL

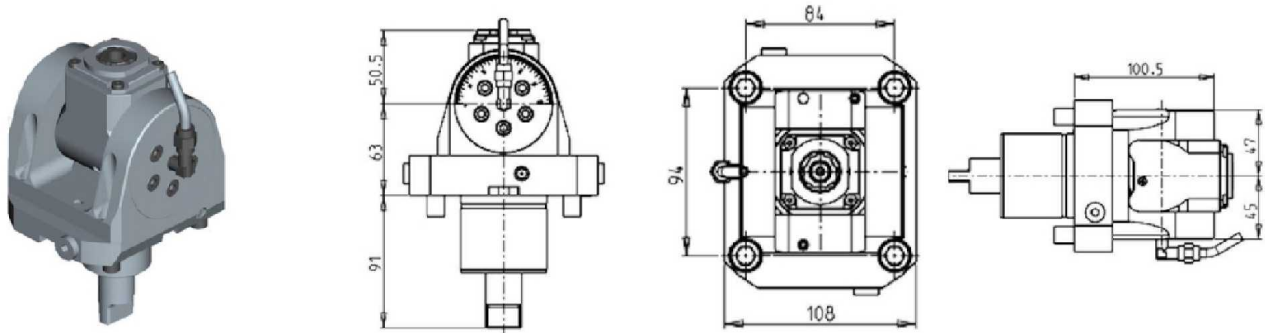

PartNumber	Description	Spindle	I	RPM	Cool Thru	Ext Cool
MNL0640316	0-180° Adj. Angle Geared-Up 1:2 ERA16	ERA16	1:2	12000		X
MNL0640416	0-180° Adj. Angle Geared-Up 1:2 ERA16 Cool Thru*	ERA16	1:2	12000	X	X

* Coolant Thru tools are designed for 1000 psi.
They require 5 Micron Filtration and **CANNOT** be run dry.

Note :

Wrenches are provided with the purchase of Specialty Toolholders

DRIVEN

TS3000/4000/5000 Y/YS 12 ST. (3 KEYS TURRET)

0-180° ADJUSTABLE ANGLE GEARED-UP 1:2 DRIVEN TOOL WITH DIGITAL DISPLAY

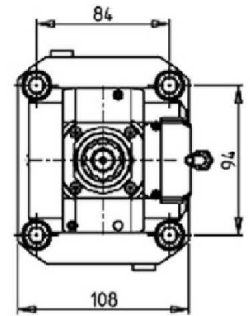
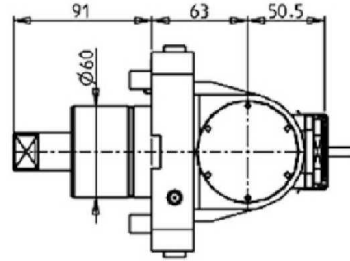
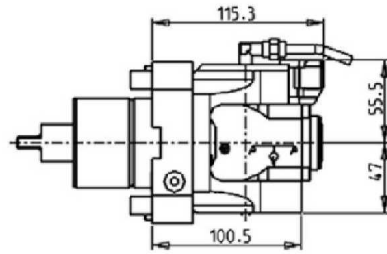

PartNumber	Description	Spindle	I	RPM	Cool Thru	Ext Cool
MNL0645316	0-180° Adj. Angle Geared-Up 1:2 ERA16 with Digital Display	ERA16	1:2	12000		X
MNL0645416	0-180° Adj. Angle Geared-Up 1:2 ERA16 with Digital Display Cool Thru*	ERA16	1:2	12000	X	X

* Coolant Thru tools are designed for 1000 psi.
They require 5 Micron Filtration and **CANNOT** be run dry.

Note :

Wrenches are provided with the purchase of Specialty Toolholders

DRIVEN

TS3000/4000/5000 Y/YS 12 ST. (3 KEYS TURRET)

DRIVEN GEAR HOBBER

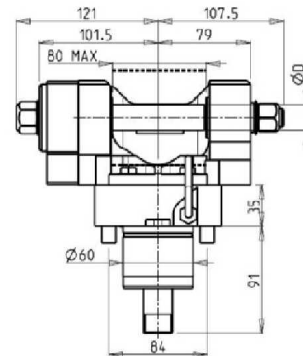
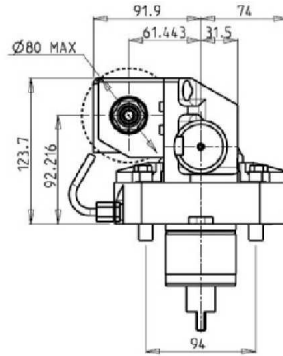
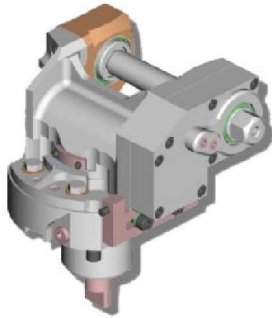

PartNumber	Description	Reversible	I	RPM	Ext Cool	D mm	D Inch
MNL0151100	Gear Hobbing Tool 1:1	X	1:1	6000	X	16-22-27-32	3/4"-1"-1 1/4"
MNL0152100	Gear Hobbing Tool 2:1 Geared Down	X	2:1	3000	X	16-22-27-32	3/4"-1"-1 1/4"

Note : Wrenches are provided with the purchase of Specialty Toolholders

GEAR HOBBER - HEAVY DUTY TOOL

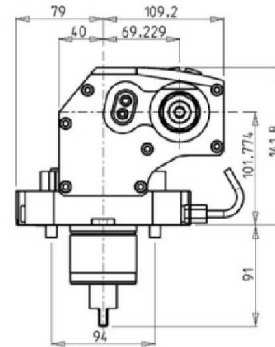
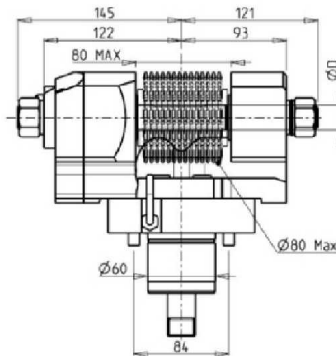
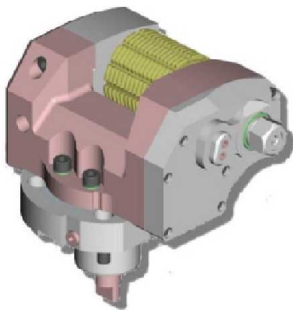

PartNumber	Description	Reversible	I	RPM	Ext Cool	D mm	D Inch
MNL0411100	Heavy Duty Gear Hobbing Tool 1:1	X	1:1	6000	X	16-22-27-32	3/4"-1"-1 1/4"
MNL0412100	Heavy Duty Gear Hobbing Tool 2:1 Geared Down	X	2:1	3000	X	16-22-27-32	3/4"-1"-1 1/4"

Note : Wrenches are provided with the purchase of Specialty Toolholders

DRIVEN

TS3000/4000/5000 Y/YS 12 ST. (3 KEYS TURRET)

LARGE DRIVEN GEAR HOBBER

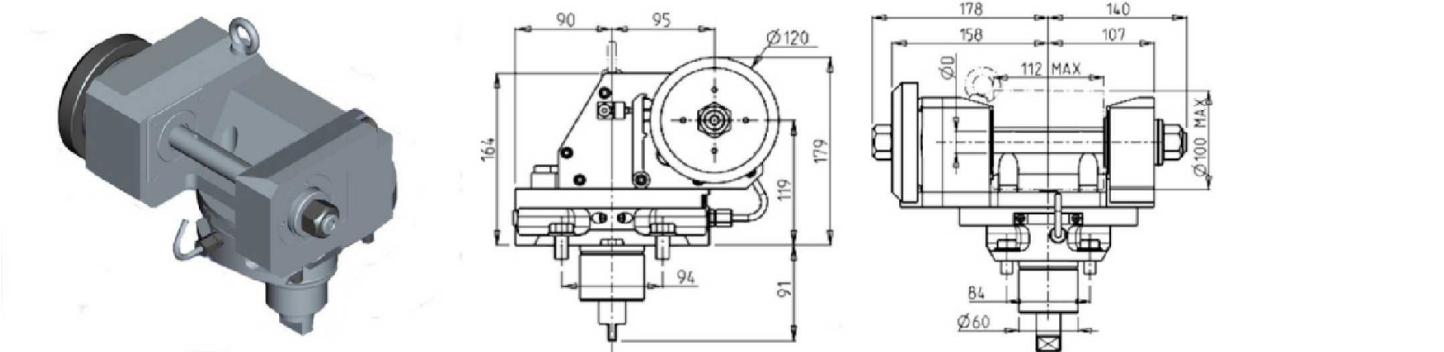

PartNumber	Description	I	RPM	Ext Cool	D (mm)
MNL0671100	Large Gear Hobber 1:1	1:1	6000	X	22-27-32
MNL0672100	Large Gear Hobber 2:1 Geared Down	2:1	3000	X	22-27-32

Note : Wrenches are provided with the purchase of Specialty Toolholders

QUICK CHANGE AXIAL MTSK DRIVEN TOOL FOR POWER SKIVING H=106mm

Please see Accessories for MTSK Clamping Units

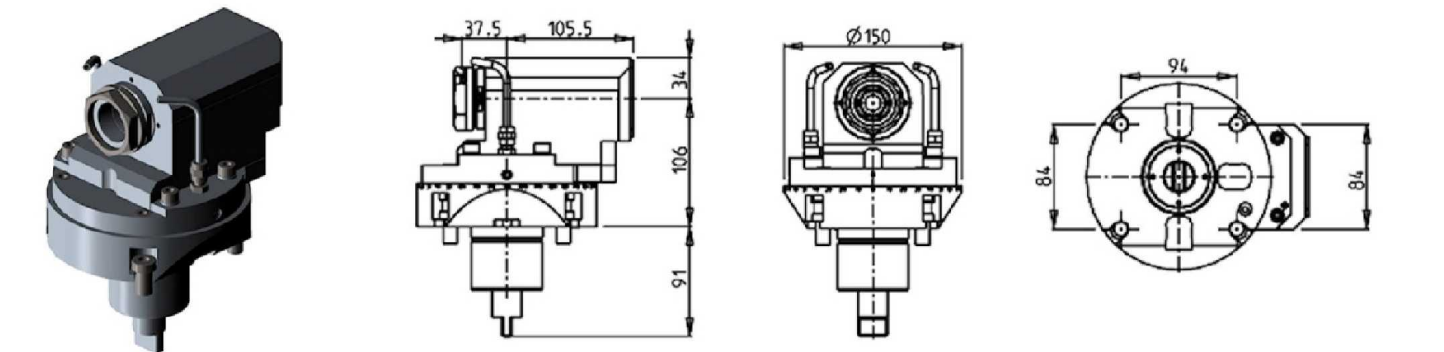

PartNumber	Description	Spindle	I	RPM	Ext Cool
MNL0870100	Axial MTSK-40 for Power Skiving	MTSK-40	1:1	6000	X

Note : Wrenches are provided with the purchase of Specialty Toolholders

DRIVEN

TS3000/4000/5000 Y/YS 12 ST. (3 KEYS TURRET)

±45° Y AXIS ADJUSTABLE ANGLE DRIVEN TOOL

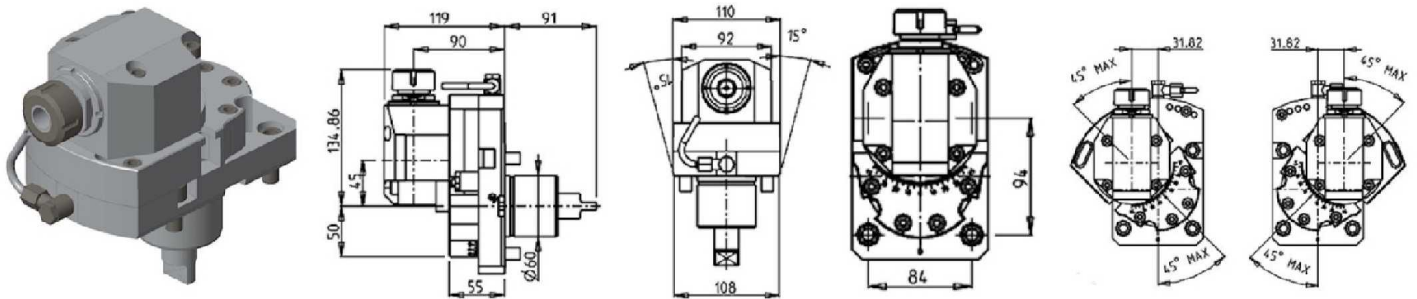

PartNumber	Description	Spindle	I	RPM	Reversible	Ext Cool
MNL1100125	±45° Y Axis Adjustable Angle ER25	ER25	1:1	6000	X	X

WORM GEAR DRIVEN TOOL

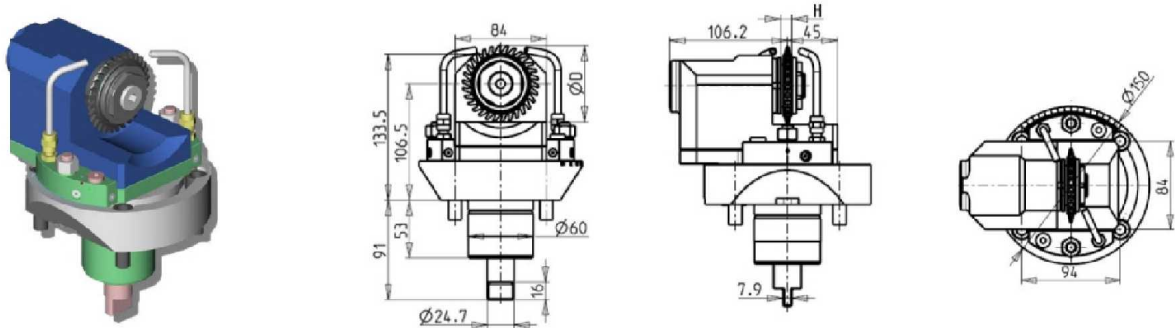

PartNumber	Description	Spindle	I	RPM	Ext Cool	D	H
MNL0378125	Driven Worm Gear Tool 1"x12mm	1"x12	1:1	6000	X	63-70-80	Max 12
MNL0378022	Driven Worm Gear Tool 22mmx17mm	22x12	1:1	6000	X	63-70-80	Max 12

Note : Wrenches are provided with the purchase of Specialty Toolholders

DRIVEN

TS3000/4000/5000 Y/YS 12 ST. (3 KEYS TURRET)

BROACHING/SLOTING DRIVEN TOOL 50mm STROKE H=94mm

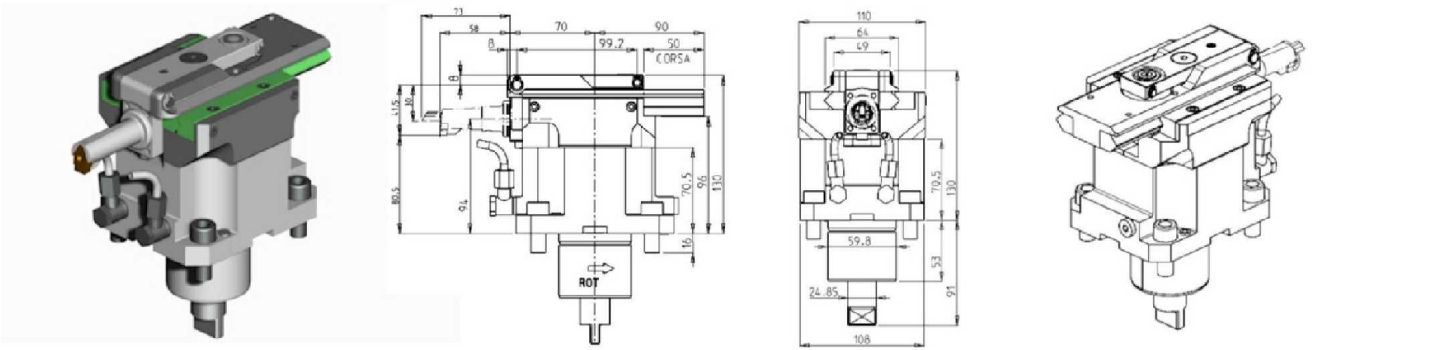

PartNumber	Description	Reversible	I	RPM MAX	Ext Cool
MNL0650100	Broaching / Slotting Tool	X	4:1	2000	X

BROACHING/SLOTING DRIVEN TOOL 25mm STROKE H=94mm

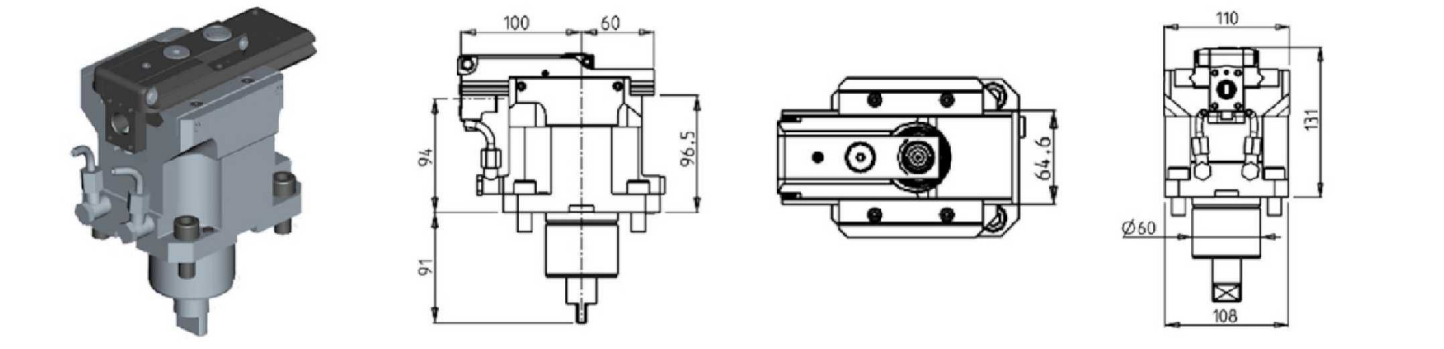

PartNumber	Description	Reversible	I	RPM Max	Ext Cool
MNL0650200	Broaching / Slotting Tool	X	4:1	2400	X

STATIC

TS3000/4000/5000 Y/YS 12 ST. (3 KEYS TURRET)

RADIAL SINGLE STATIC TOOL

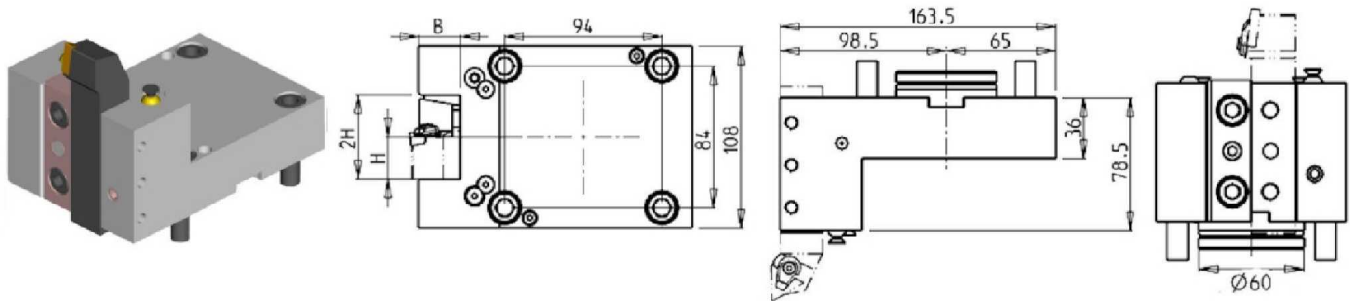

PartNumber	Description	# of Tools	Reversible	Cool Thru	Ext Cool	Dimensions	B	H
MNL0041905	Radial Single Static 3/4"	1	X		X	Inch	3/4"	3/4"
MNL0042540	Radial Single Static 1"	1	X		X	Inch	1"	1"
MNL0042000	Radial Single Static 20mm	1	X		X	mm	20	20
MNL0042500	Radial Single Static 25mm	1	X		X	mm	25	25
MNL0042510	Radial Single Static 25mm Cool Thru*	1	X	X	X	mm	25	25

RADIAL SINGLE STATIC TOOL

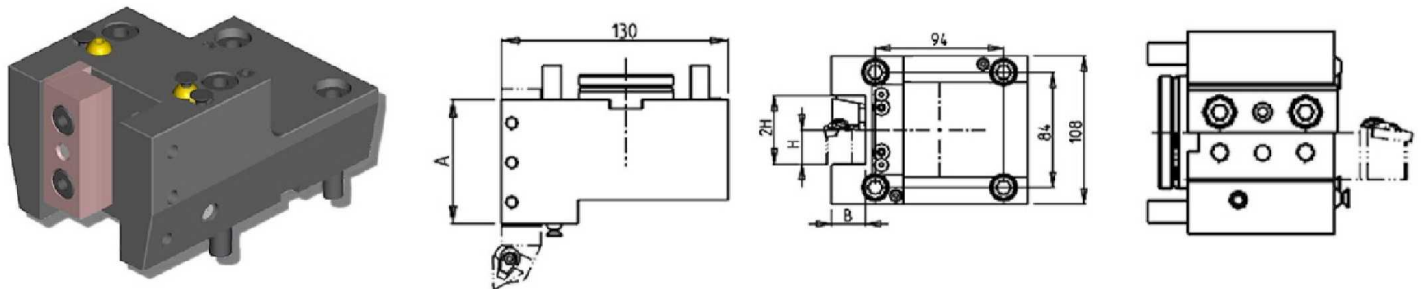

PartNumber	Description	# of Tools	Reversible	Dimensions	A	B	H
MNL0042000_CH	Radial Single Static 20mm	1/2	X	mm	65	20	20
MNL0042500_CH	Radial Single Static 25mm	1/2	X	mm	70	25	25

RADIAL SINGLE STATIC TOOL

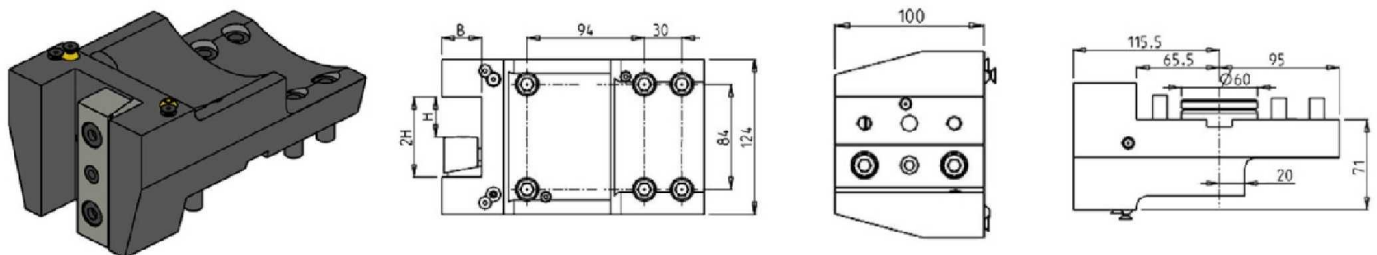

PartNumber	Description	# of Tools	Dimensions	B	H
MNL0043175	Radial Single Static 1-1/4"	1	Inch	1-1/4"	1-1/4"
MNL0043200	Radial Single Static 32mm	1	mm	32	32

STATIC

TS3000/4000/5000 Y/YS 12 ST. (3 KEYS TURRET)

RADIAL REAR-SET SINGLE STATIC TOOL

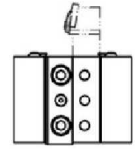
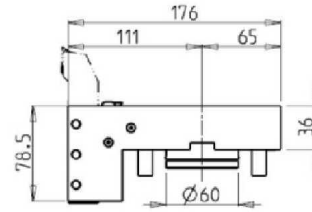
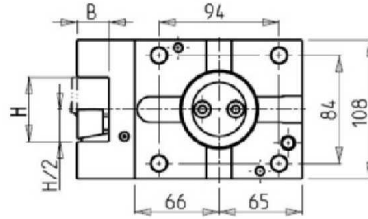
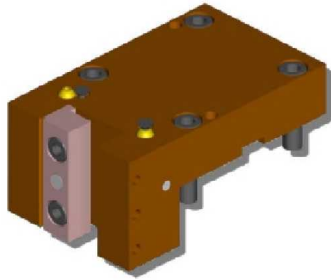

PartNumber	Description	# of Tools	Dimensions	B	H
MNL0381905	Radial Rear-Set Single Tool 3/4"	1/2	Inch	3/4"	3/4"
MNL0382540	Radial Rear-Set Single Tool 1"	1/2	Inch	1"	1"
MNL0382000	Radial Rear-Set Single Tool 20mm	1/2	mm	20	20
MNL0382500	Radial Rear-Set Single Tool 25mm	1/2	mm	25	25

RADIAL SINGLE SIDE TWIN STATIC TOOL

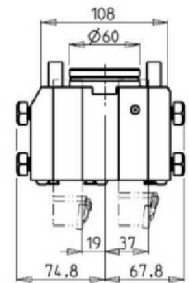
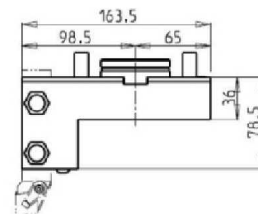
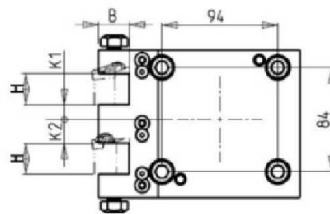
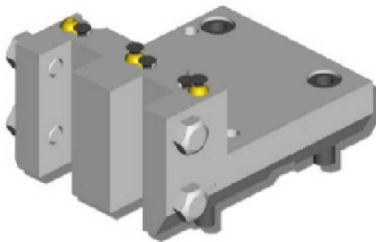

PartNumber	Description	# of Tools	Reversible	Dimensions	H	B	K1	K2
MNL0061905	Radial Single Side Double Tool 3/4"	2	X	Inch	3/4"	3/4"	1/2"	3/4"
MNL0062540	Radial Single Side Double Tool 1"	2	X	Inch	1"	1"	1/2"	3/4"
MNL0062000	Radial Single Side Double Tool 20mm	2	X	mm	20	20	12	19
MNL0062500	Radial Single Side Double Tool 25mm	2	X	mm	25	25	12	19

STATIC

TS3000/4000/5000 Y/YS 12 ST. (3 KEYS TURRET)

RADIAL DOUBLE STATIC TOOL

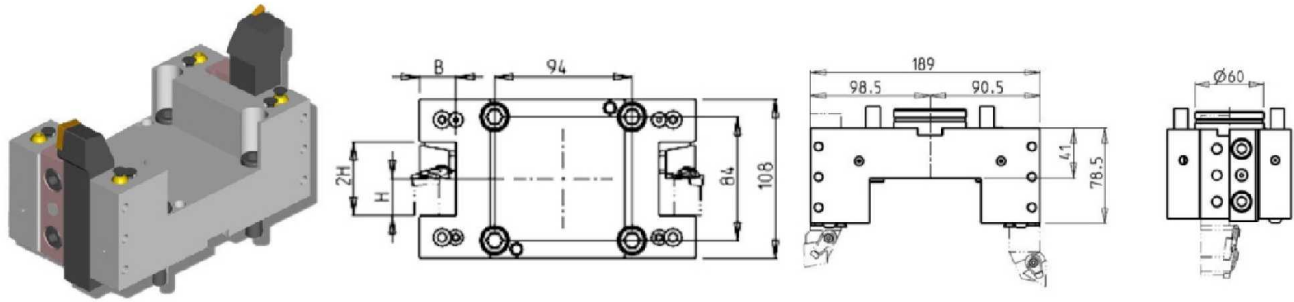

PartNumber	Description	# of Tools	Reversible	Dimensions	B	H
MNL0051905	Radial Double Static Tool 3/4"	2/4	X	Inch	3/4"	3/4"
MNL0052540	Radial Double Static Tool 1"	2/4	X	Inch	1"	1"
MNL0052000	Radial Double Static Tool 20mm	2/4	X	mm	20	20
MNL0052500	Radial Double Static Tool 25mm	2/4	X	mm	25	25

RADIAL DOUBLE SIDE TWIN STATIC TOOL

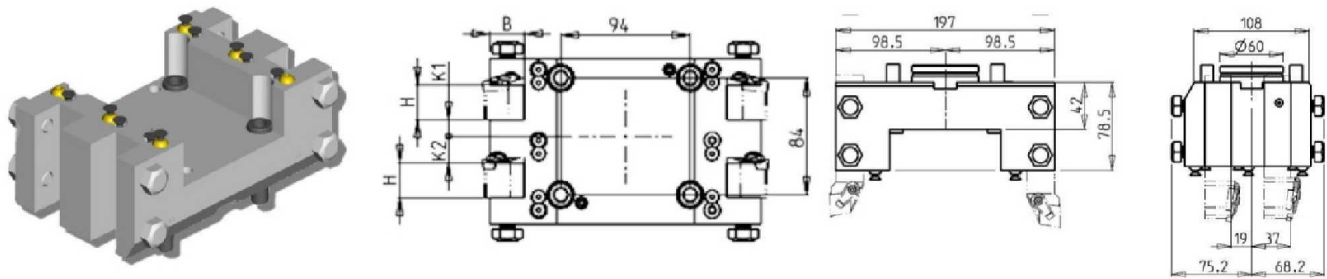

PartNumber	Description	# of Tools	Reversible	Dimensions	H	B	K1	K2
MNL0071905	Radial Double Side Twin Static Tool 3/4"	4	X	Inch	3/4"	3/4"	1/2"	3/4"
MNL0072540	Radial Double Side Twin Static Tool 1"	4	X	Inch	1"	1"	1/2"	3/4"
MNL0072000	Radial Double Side Twin Static Tool 20mm	4	X	mm	20	20	12	19
MNL0072500	Radial Double Side Twin Static Tool 25mm	4	X	mm	25	25	12	19

STATIC

TS3000/4000/5000 Y/YS 12 ST. (3 KEYS TURRET)

RADIAL DOUBLE BLADE HOLDER WITH BLADE KIT

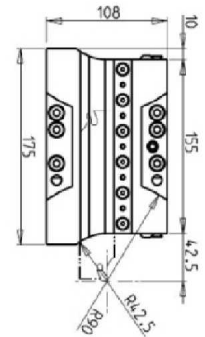
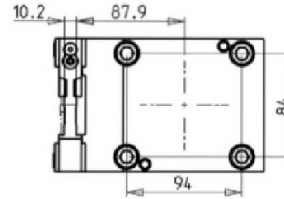
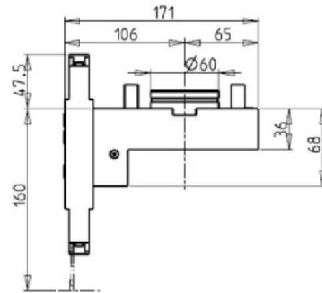
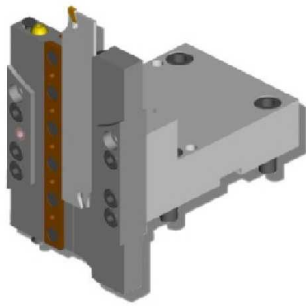

PartNumber	Description	# of Tools
MNL0140132	Radial Double Blade Holder wth Blade Kit	1
BLADEKIT	Blade Kit: 1 Blade, 10 Inserts	

RADIAL DOUBLE TWIN SIDE BLADE HOLDER WITH BLADE KIT

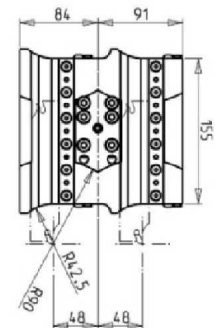
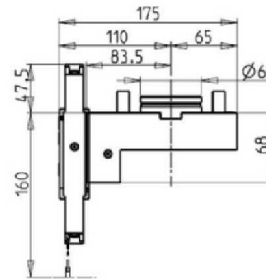
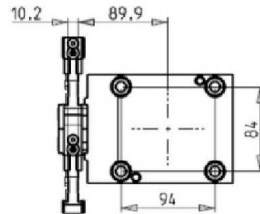
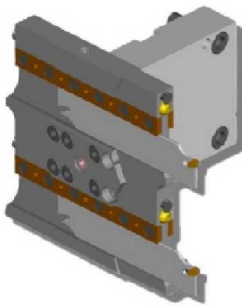

PartNumber	Description	# of Tools
MNL0160232	Radial Double Twin-Side Blade Holder with Blade Kit	2
BLADEKIT-2	Blade Kit: 2 Blade, 20 Inserts	

RADIAL DOUBLE BLADE HOLDER WITH INTERNAL COOLANT- BLADE KIT NOT INCLUDED

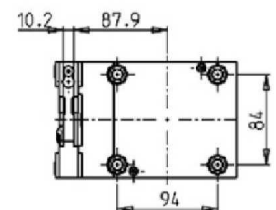
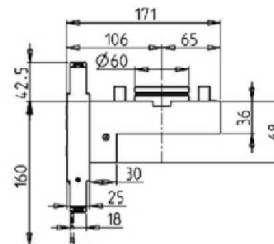
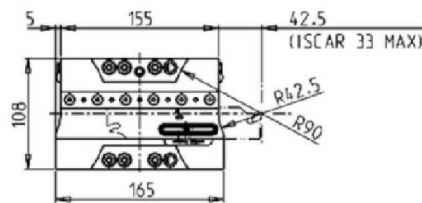
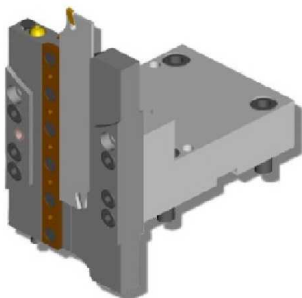

PartNumber	Description	# of Tools	Ext Cool	Cool Thru
MNL0860132	Radial Blade Holder Cool Thru	1	X	X
COOL THRU BLADEKIT	Blade Kit: 1 Blade, 10 Inserts			

STATIC

TS3000/4000/5000 Y/YS 12 ST. (3 KEYS TURRET)

AXIAL SINGLE STATIC TOOL

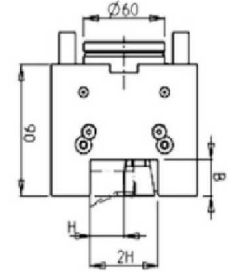
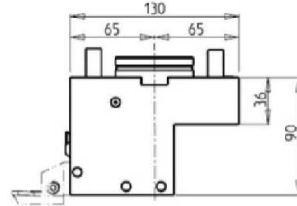
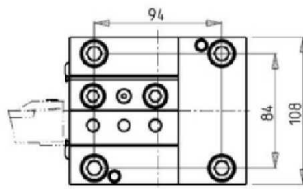
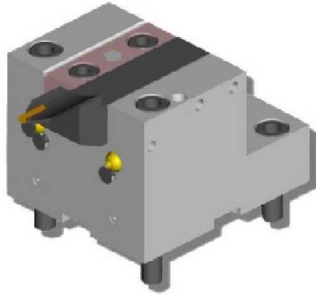

PartNumber	Description	# of Tools	Reversible	Dimensions	B	H
MNL0131905	Axial Single Position Tool 3/4"	1/2	X	Inch	3/4"	3/4"
MNL0132540	Axial Single Position Tool 1"	1/2	X	Inch	1"	1"
MNL0132000	Axial Single Position Tool 20mm	1/2	X	mm	20	20
MNL0132500	Axial Single Position Tool 25mm	1/2	X	mm	25	25

AXIAL SINGLE STATIC TOOL - LOWER HEIGHT

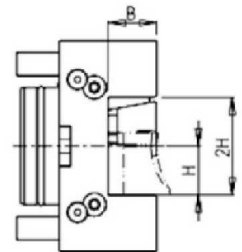
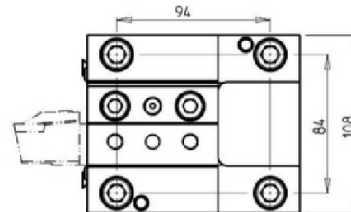
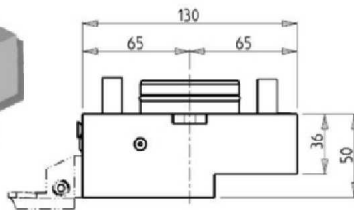
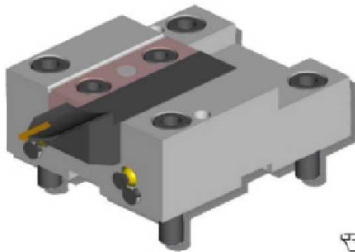

PartNumber	Description	# of Tools	Reversible	Dimensions	B	H
MNL0302000	Axial Single Static Tool - Lower Height 20mm	1	X	mm	20	20
MNL0302500	Axial Single Static Tool - Lower Height 25mm	1	X	mm	25	25

STATIC

TS3000/4000/5000 Y/YS 12 ST. (3 KEYS TURRET)

AXIAL SINGLE BORING BAR HOLDER H=80mm

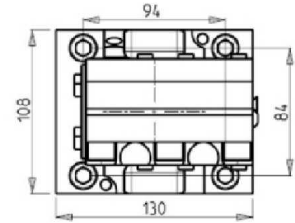
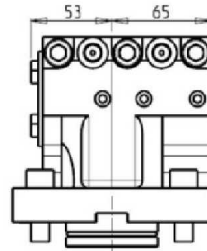
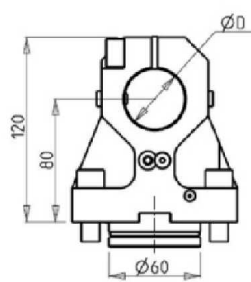
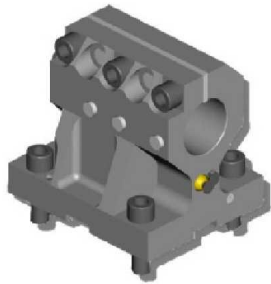

PartNumber	Description	# of Tools	Reversible	Cool Thru	Ext Cool	Dimensions	D
MNL0113810	Axial Single Boring Bar Holder 1-1/2"	1	X	X	X	Inch	1-1/2"
MNL0114000	Axial Single Boring Bar Holder 40mm	1	X	X	X	mm	40
KIT1003004	1 1/2" Plug & Seal to Make BBH Cool Thru*						
KIT1003003	40mm Plug & Seal to Make BBH Cool Thru*						

AXIAL SINGLE BORING BAR HOLDER H=80mm

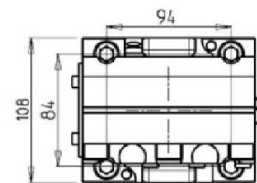
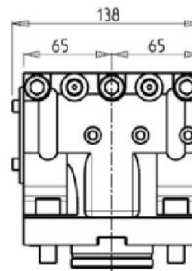
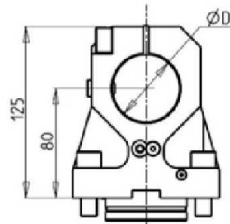
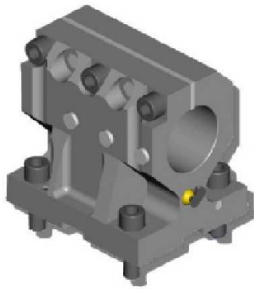

PartNumber	Description	# of Tools	Reversible	Cool Thru	Ext Cool	Dimensions	D
MNL0115080	Axial Single Boring Bar Holder 2"	1	X	X	X	Inch	2"
MNL0115000	Axial Single Boring Bar Holder 50mm	1	X	X	X	mm	50
KIT1001002	50mm or 2" Plug & Seal to Make BBH Cool Thru*						

AXIAL SINGLE BORING BAR HOLDER 60mm H=110mm

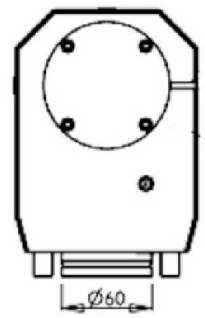
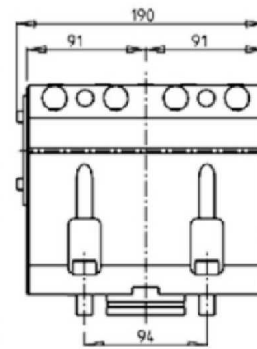
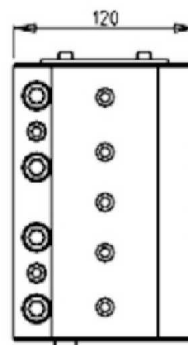
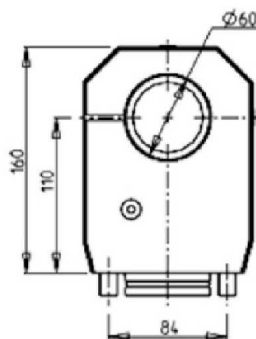

PartNumber	Description	# of Tools	Cool Thru	Ext Cool
MNL0616000	Single Boring Bar Holder 60mm	1	X	X
KIT1005025	60mm Plug & Seal to Make BBH Cool Thru*			

STATIC

TS3000/4000/5000 Y/YS 12 ST. (3 KEYS TURRET)

AXIAL SINGLE BORING BAR HOLDER 80mm H=110mm

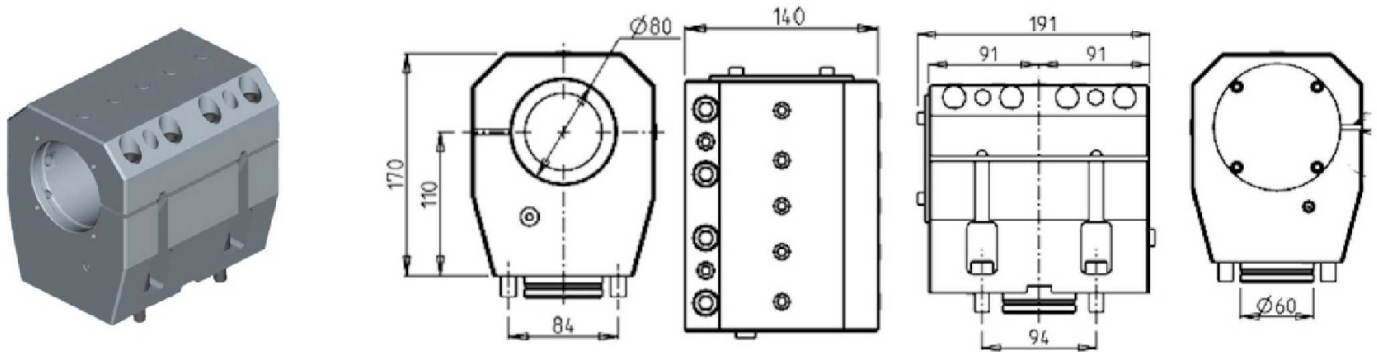

PartNumber	Description	# of Tools	Cool Thru	Ext Cool
MNL0628000	Single Boring Bar Holder 80mm	1	X	X
KIT1005013	80mm Plug & Seal to Make BBH Cool Thru*			

AXIAL SINGLE EXTENDED BORING BAR HOLDER 40mm H=115mm

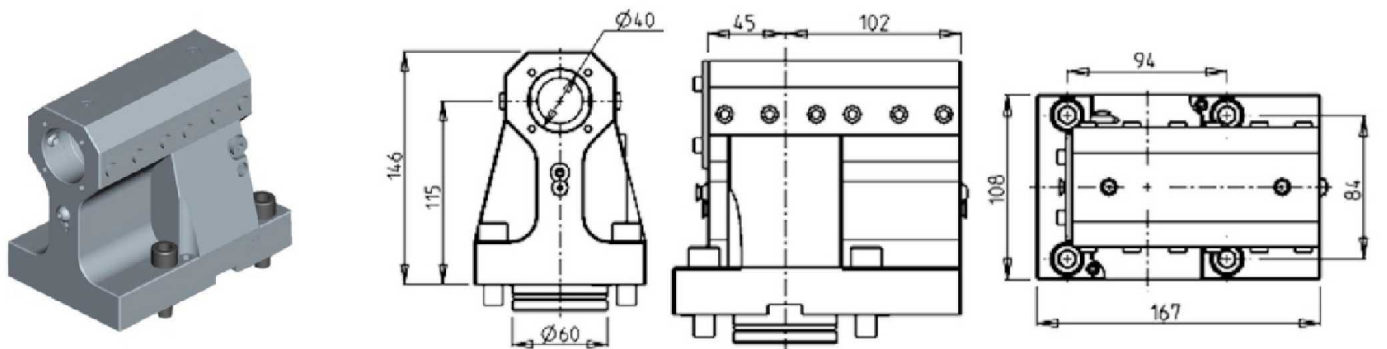

PartNumber	Description	# of Tools	Reversible	Cool Thru	Ext Cool
MNL0604000	Axial Single Extended BBH 40mm	1	X	X	X
KIT1000003	40mm Plug & Seal to Make BBH Cool Thru*				

AXIAL SINGLE EXTENDED BORING BAR HOLDER H=80mm

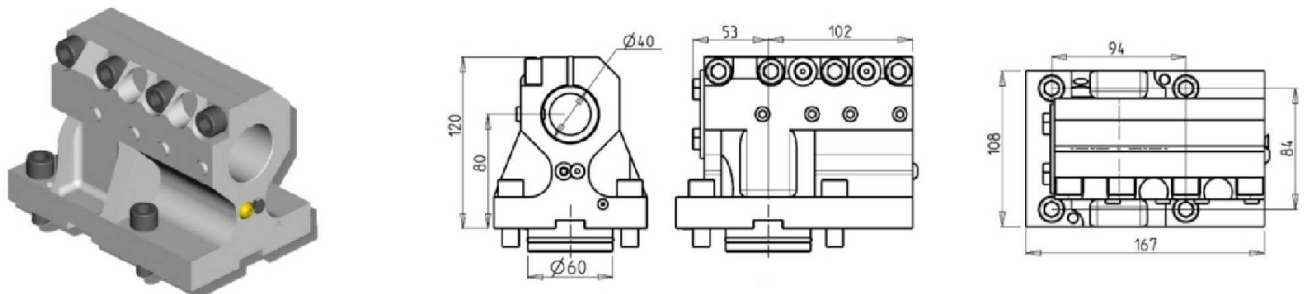

PartNumber	Description	# of Tools	Reversible	Cool Thru	Ext Cool	Dimensions	D
MNL0313810	Axial Single Extended BBH 1-1/2"	1	X	X	X	Inch	1-1/2"
MNL0314000	Axial Single Extended BBH 40mm	1	X	X	X	mm	40
KIT1002003	40mm Plug & Seal to Make BBH Cool Thru*						
KIT1002004	1-1/2" Plug & Seal to Make BBH Cool Thru*						

STATIC

TS3000/4000/5000 Y/YS 12 ST. (3 KEYS TURRET)

AXIAL 2 + 2 POSITION BORING BAR HOLDER

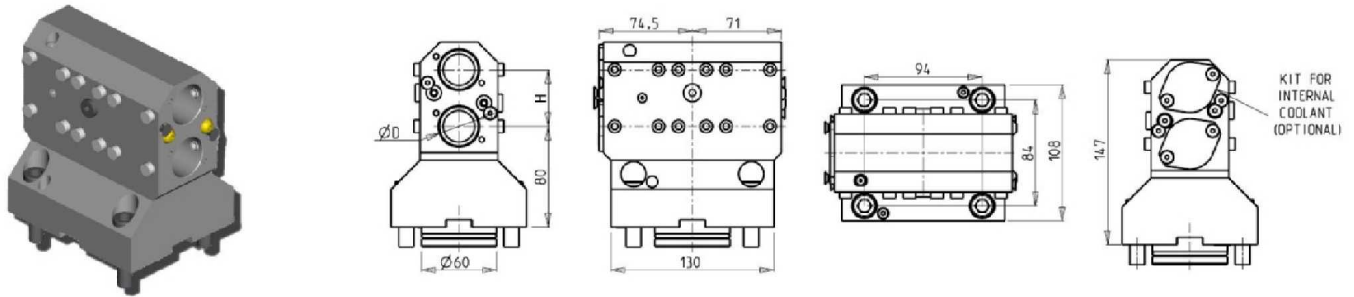

PartNumber	Description	# of Tools	Cool Thru	Ext Cool	Dimensions	D	H
MNL0103175	Axial 2+2 Boring Bar Holder 1-1/4"	2+2	X	X	Inch	1-1/4"	1-3/4"
MNL0103200	Axial 2+2 Boring Bar Holder 32mm	2+2	X	X	mm	32	45
KIT1000001	32mm or 1-1/4" Plug to Make BBH Cool Thru*						

AXIAL 3 + 3 POSITION UPRIGHT BORING BAR HOLDER

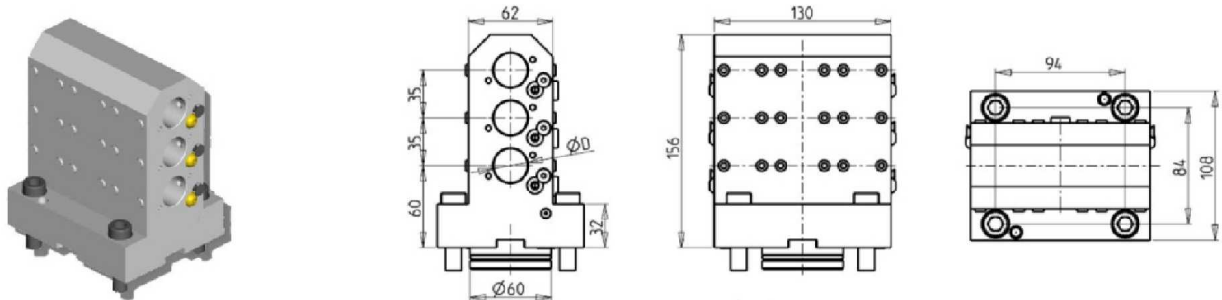

PartNumber	Description	# of Tools	Cool Thru	Ext Cool	Dimension	D
MNL0182540	Axial 3+3 Boring Bar Holder 1"	3+3	X	X	Inch	1"
MNL0182500	Axial 3+3 Boring Bar Holder 25mm	3+3	X	X	mm	25
KIT1000006	25mm or 1" Plug to Make BBH Cool Thru*					

AXIAL 3 POSITION UPRIGHT REAR SET BORING BAR HOLDER

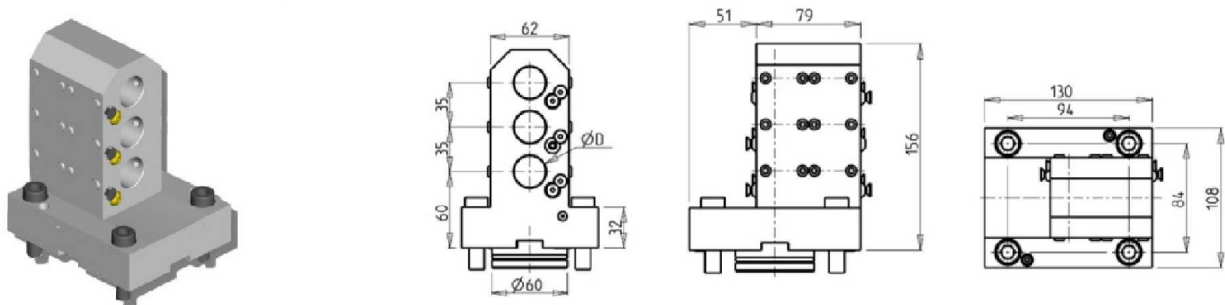

PartNumber	Description	# of Tools	Reversible	Ext Cool	Dimension	D
MNL0192540	Axial Triple Rear-Set Boring Bar Holder 1"	3	X	X	Inch	1"
MNL0192500	Axial Triple Rear-Set Boring Bar Holder 25mm	3	X	X	mm	25

STATIC

TS3000/4000/5000 Y/YS 12 ST. (3 KEYS TURRET)

AXIAL 3 + 3 POSITION BORING BAR HOLDER

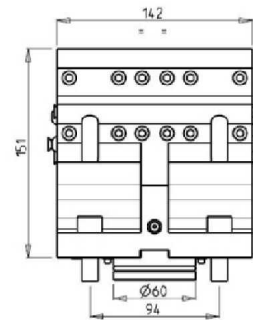
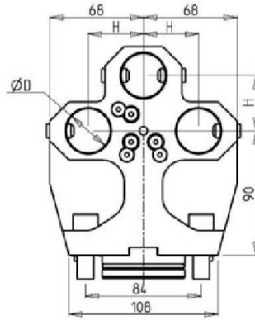
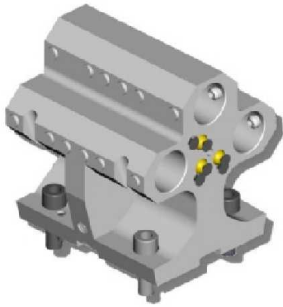

PartNumber	Description	# of Tools	Cool Thru	Ext Cool	Dimension	D	H	
MNL0093175	Axial 3+3 Boring Bar Holder 1-1/4"	3+3	X	X	Inch	1-1/4"	1-1/2"	
MNL0093200	Axial 3+3 Boring Bar Holder 32mm	3+3	X	X	mm	32	40	
KIT1000001	32mm or 1-1/4" Plug to Make BBH Cool Thru*							

AXIAL 4 + 4 POSITION BORING BAR HOLDER

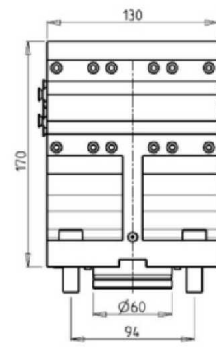
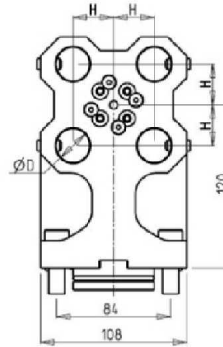
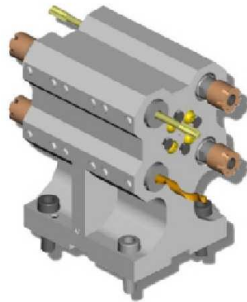

PartNumber	Description	# of Tools	Ext Cool	Dimension	D	H
MNL0082540	Axial 4+4 Boring Bar Holder 1"	4+4	X	Inch	1"	1 1/4"
MNL0082500	Axial 4+4 Boring Bar Holder 25mm	4+4	X	mm	25	30

AXIAL 8 POSITION BORING BAR HOLDER

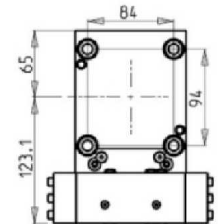
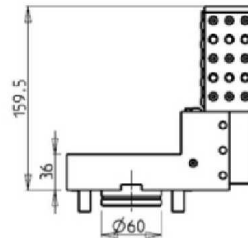
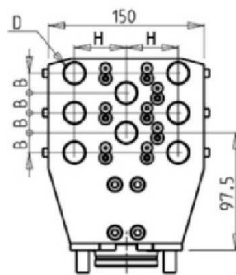
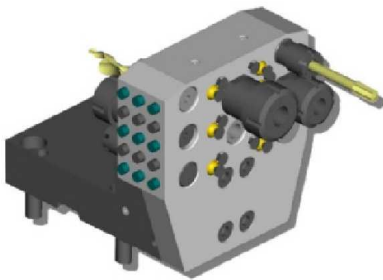

PartNumber	Description	# of Tools	Reversible	Ext Cool	Dimensions	D	B	H
MNL0121905	Axial 8-Position Boring Bar Holder 3/4"	8	X	X	Inch	3/4"	5/8"	2"
MNL0122000	Axial 8-Position Boring Bar Holder 20mm	8	X	X	mm	20	16	50

STATIC

TS3000/4000/5000 Y/YS 12 ST. (3 KEYS TURRET)

TAILSTOCK FOR SUB-SPINDLE

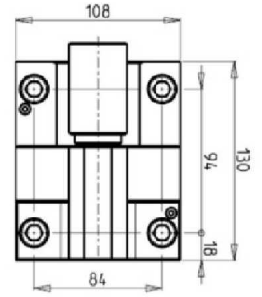
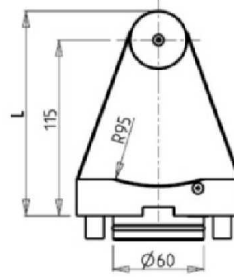
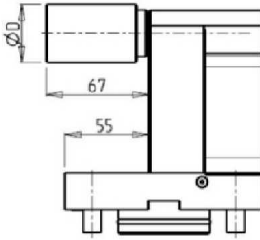
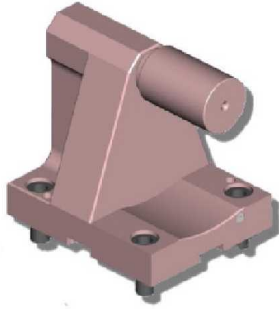

PartNumber	Description	# of Tools	D	L
MNL0360100L	Tailstock for Sub-Spindle 2"	1	2"	140.4
MNL0360100	Tailstock for Sub-Spindle 38mm	1	38mm	134

CAPTO DRIVEN

TS3000/4000/5000 Y/YS 12 ST. (3 KEYS TURRET)

RADIAL DRIVEN TOOL CAPTO

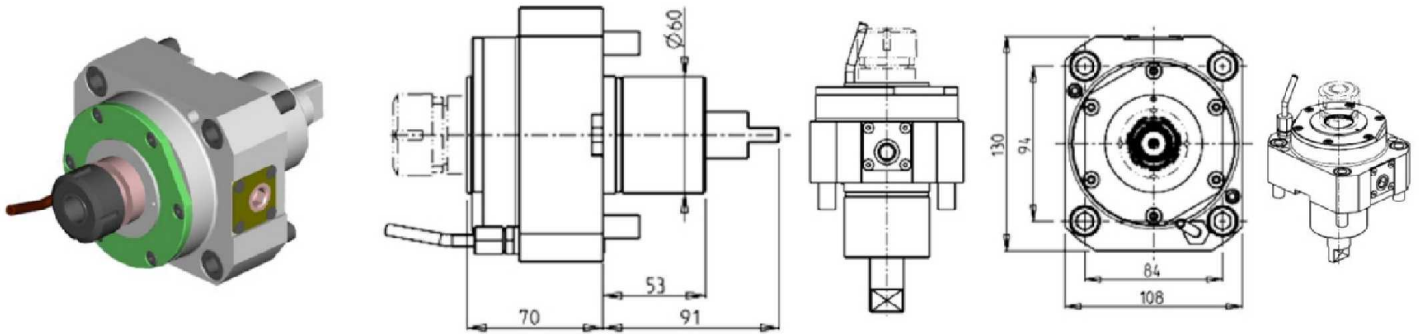

PartNumber	Description	Size	I	RPM	Ext Cool
MNL0530140	Radial Capto C4	C4	1:1	6000	X
MNL0530150	Radial Capto C5	C5	1:1	6000	X

CAPTO DRIVEN

TS3000/4000/5000 Y/YS 12 ST. (3 KEYS TURRET)

AXIAL DRIVEN TOOL CAPTO

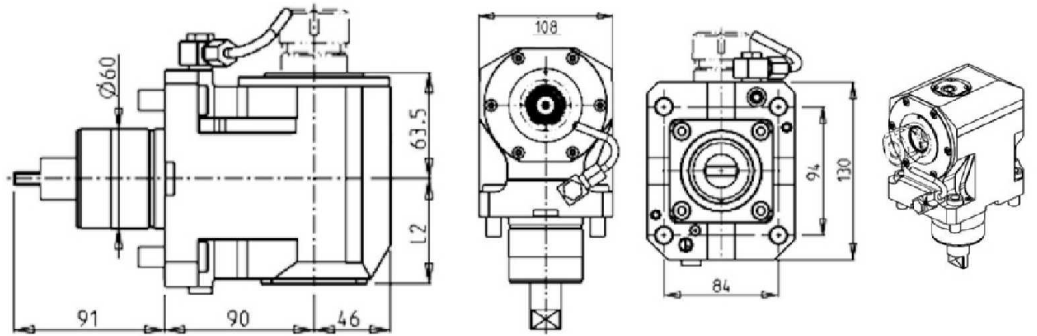
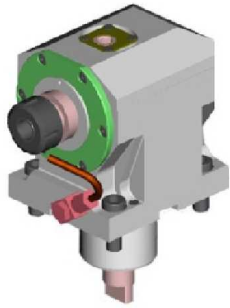

PartNumber	Description	Size	I	RPM	Reversible	Cool Thru	Ext Cool	L2
MNL0520140	Axial Capto C4	C4	1:1	6000	X		X	63
MNL0520240	Axial Capto C4 Cool Thru*	C4	1:1	6000	X	X	X	75.5
MNL0520150	Axial Capto C5	C5	1:1	6000	X		X	63
MNL0520250	Axial Capto C5 Cool Thru*	C5	1:1	6000	X	X	X	75.5

* Coolant Thru tools are designed for 1000 psi.
They require 5 Micron Filtration and **CANNOT** be run dry.

AXIAL OPPOSITE FACE TWIN DRIVEN TOOL CAPTO

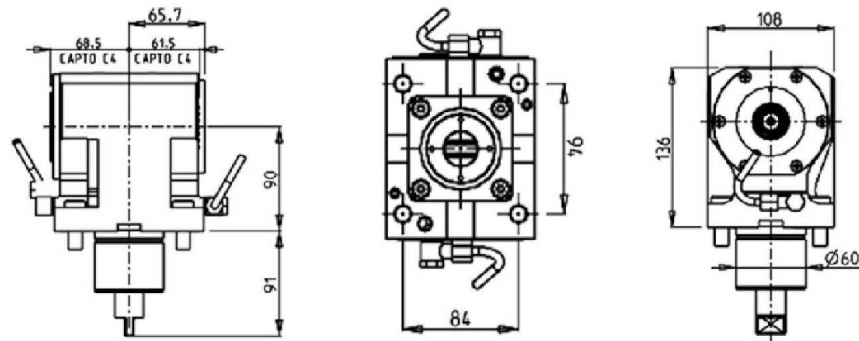

PartNumber	Description	Size	I	RPM	Reversible	Ext Cool
MNL1170240	Axial Opposite Face Capto C4+C4	C4+C4	1:1	6000	X	X

CAPTO STATIC

TS3000/4000/5000 Y/YS 12 ST. (3 KEYS TURRET)

RADIAL SINGLE STATIC TOOL - CAPTO

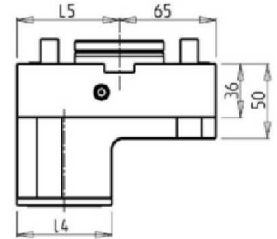
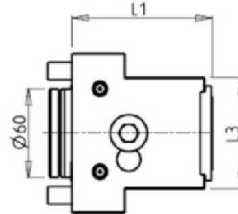
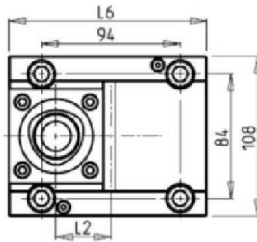
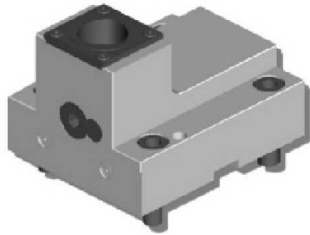

PartNumber	Description	# of Tools	Cool Thru	Reversible	Size	L1	L2	L3	L4	L5	L6
MNL0464010	Single Radial Static Tool: Right C4 Capto	1	X	X	C4	90	45	63	48	69	134
MNL0464010LC	Single Radial Static Tool: Left C4 Capto	1	X	X	C4	90	45	63	48	69	134
MNL0465010	Single Radial Static Tool: Right C5 Capto	1	X	X	C5	95	37	75	64	69	134
MNL0465010LC	Single Radial Static Tool: Left C5 Capto	1	X	X	C5	95	37	75	64	69	134
MNL0465015	Single Radial Static Tool: Right C5 Capto	1	X	X	C5	95	62.5	75	64	94.5	159.5
MNL0465015LC	Single Radial Static Tool: Left C5 Capto	1	X	X	C5	95	62.5	75	64	94.5	159.5
MNL0466010	Single Radial Static Tool: Right C6 Capto	1	X	X	C6	108	55	108	94	97	162
MNL0466010LC	Single Radial Static Tool: Left C6 Capto	1	X	X	C6	108	55	108	94	97	162

RADIAL DOUBLE STATIC TOOL - CAPTO

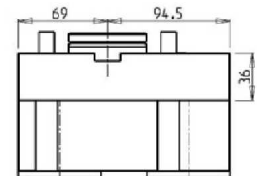
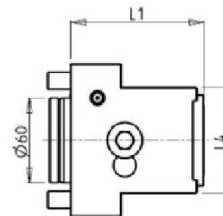
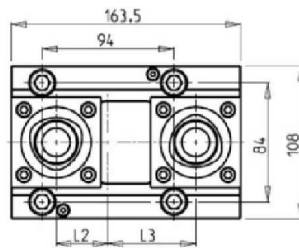
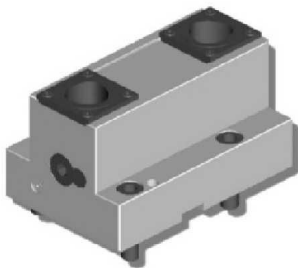

PartNumber	Description	# of Tools	Cool Thru	Size	L1	L2	L3	L4
MNL0474020	Radial Double Static Tool: Right C4 Capto	2	X	C4	90	45	70.5	63
MNL0474020LC	Radial Double Static Tool: Left C4 Capto	2	X	C4	90	45	70.5	63
MNL0475020	Radial Double Static Tool: Right C5 Capto	2	X	C5	95	37	62.5	75
MNL0475020LC	Radial Double Static Tool: Left C5 Capto	2	X	C5	95	37	62.5	75

CAPTO STATIC

TS3000/4000/5000 Y/YS 12 ST. (3 KEYS TURRET)

RADIAL DOUBLE 2+2 UPRIGHT POSITION STATIC TOOL - CAPTO

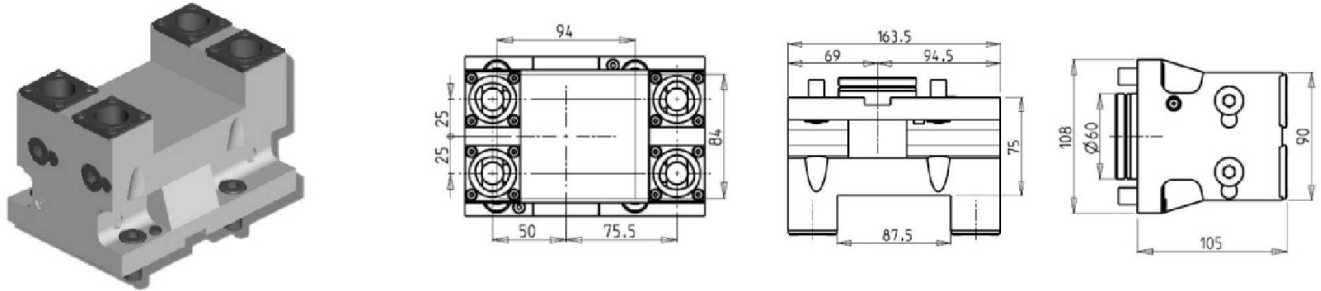

PartNumber	Description	# of Tools	Cool Thru	Size
MNL0483240	Radial Double 2+2 Static Tool: Right C3 Capto	4	X	C3
MNL0483240LC	Radial Double 2+2 Static Tool: Left C3 Capto	4	X	C3

RADIAL DOUBLE 3+3 UPRIGHT POSITION STATIC TOOL - CAPTO

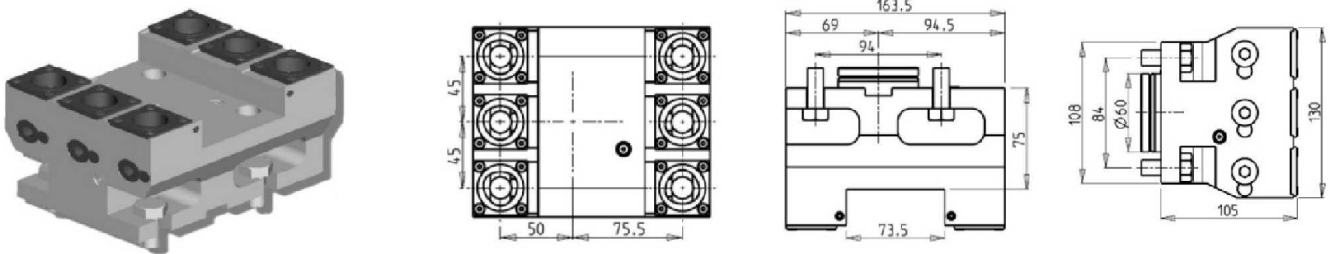

PartNumber	Description	# of Tools	Cool Thru	Size
MNL0483260	Radial Double 3+3 Static Tool: Right C3 Capto	6	X	C3
MNL0483260LC	Radial Double 3+3 Static Tool: Left C3 Capto	6	X	C3

CAPTO STATIC

TS3000/4000/5000 Y/YS 12 ST. (3 KEYS TURRET)

AXIAL SINGLE STATIC TOOL - CAPTO

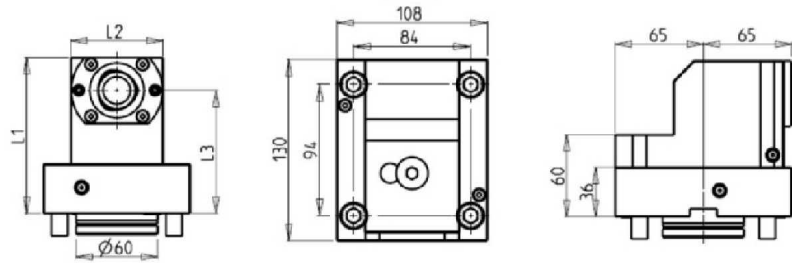
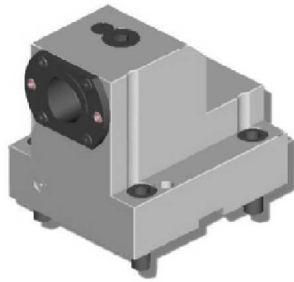

PartNumber	Description	# of Tools	Cool Thru	Reversible	Size	L1	L2	L3
MNL0494010	Axial Single Static Tool: Right C4 Capto	1	X	X	C4	114	68	90
MNL0494010LC	Axial Single Static Tool: Left C4 Capto	1	X	X	C4	114	68	90
MNL0495010	Axial Single Static Tool: Right C5 Capto	1	X	X	C5	122	83	90
MNL0495010LC	Axial Single Static Tool: Left C5 Capto	1	X	X	C5	122	83	90
MNL0495015	Axial Single Static Tool: Right C5 Capto	1	X	X	C5	152	83	120
MNL0495015LC	Axial Single Static Tool: Left C5 Capto	1	X	X	C5	152	83	120
MNL0496010	Axial Single Static Tool: Right C6 Capto	1	X	X	C6	132	108	90
MNL0496010LC	Axial Single Static Tool: Left C6 Capto	1	X	X	C6	132	108	90

AXIAL SINGLE STATIC TOOL - CAPTO C6

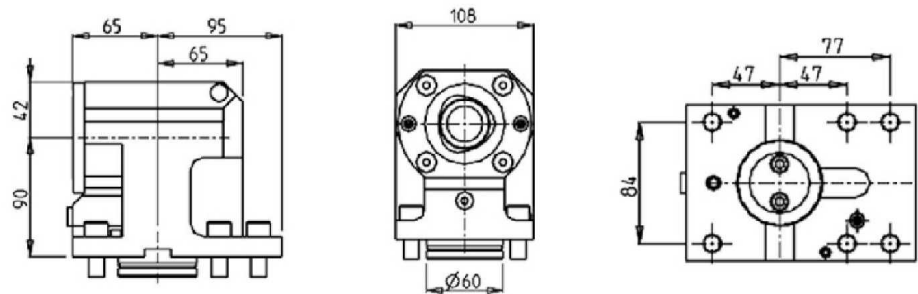
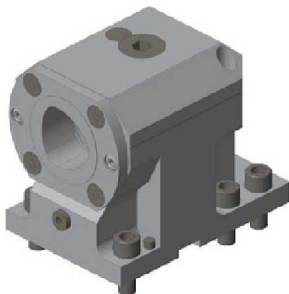

PartNumber	Description	# of Tools	Cool Thru	Ext Cool	Size
MNL1196010	Axial Single Static Tool: Right C6 Capto	1	X	X	C6
MNL1196010LC	Axial Single Static Tool: Left C6 Capto	1	X	X	C6

CAPTO STATIC

TS3000/4000/5000 Y/YS 12 ST. (3 KEYS TURRET)

AXIAL REAR-SET BORING SINGLE STATIC TOOL - CAPTO

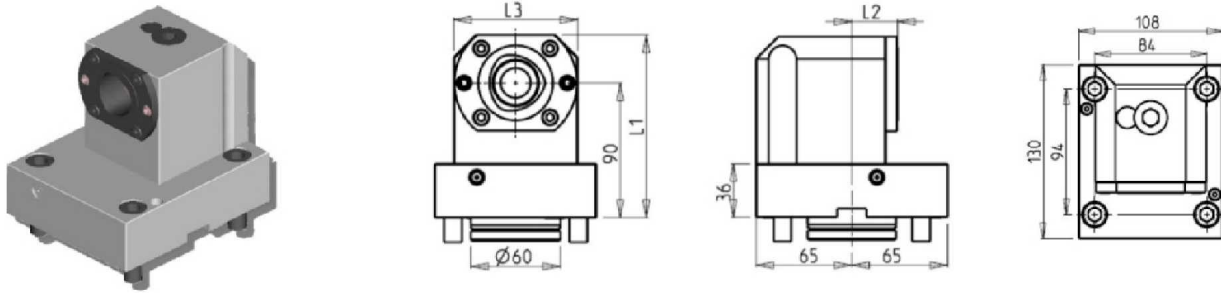

PartNumber	Description	# of Tools	Cool Thru	Reversible	Size	L1	L2	L3
MNL0514010	Axial Rear-Set Boring Static Tool: Right C4 Capto	1	X	X	C4	114	21	68
MNL0514010LC	Axial Rear-Set Boring Static Tool: Left C4 Capto	1	X	X	C4	114	21	68
MNL0515010	Axial Rear-Set Boring Static Tool: Right C5 Capto	1	X	X	C5	122	31	83
MNL0515010LC	Axial Rear-Set Boring Static Tool: Left C5 Capto	1	X	X	C5	122	31	83

AXIAL OPPOSITE FACE TWIN STATIC TOOL - CAPTO

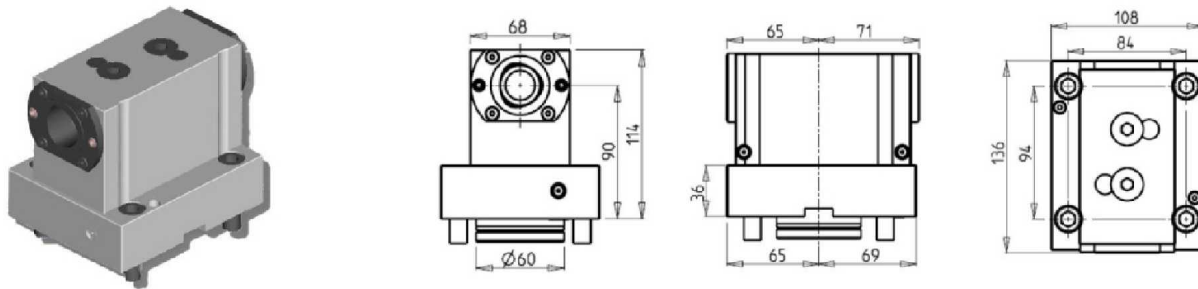

PartNumber	Description	# of Tools	Cool Thru	Reversible	Size
MNL0504020	Axial Opposite Face Twin Static Tool: Right C4 Capto	1+1	X	X	C4
MNL0504020LC	Axial Opposite Face Twin Static Tool: Left C4 Capto	1+1	X	X	C4

DRIVEN

TT-2600CM

RADIAL DRIVEN TOOL REDIRECTED IN Z BY 80mm

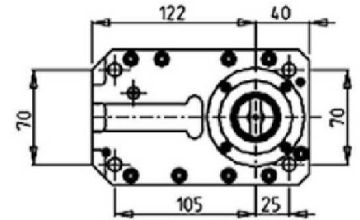
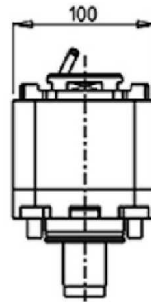
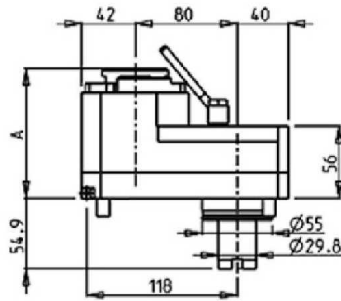

PartNumber	Description	Spindle	I	RPM	Cool Thru	Ext Cool	A
TKW0570332	Radial Redirected in Z by 80mm ERA32	ERA32	1:1	4000		X	101
TKW0570432	Radial Redirected in Z by 80mm ERA32 Cool Thru*	ERA32	1:1	4000	X	X	111

* Coolant Thru tools are designed for 1000 psi.
They require 5 Micron Filtration and **CANNOT** be run dry.

RADIAL GEARED-DOWN 2:1 DRIVEN TOOL REDIRECTED IN Z BY 80mm

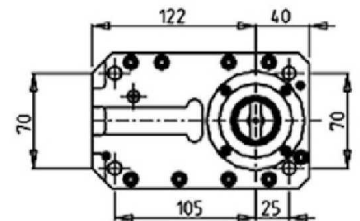
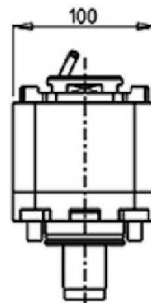
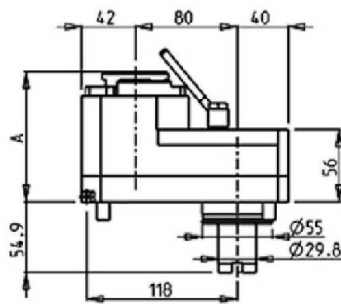

PartNumber	Description	Spindle	I	RPM	Cool Thru	Ext Cool	A
TKW0571332	Radial Geared-Down 2:1 Redirected ERA32	ERA32	2:1	2000		X	101
TKW0571432	Radial Geared-Down 2:1 Redirected ERA32 Cool Thru*	ERA32	2:1	2000	X	X	111

* Coolant Thru tools are designed for 1000 psi.
They require 5 Micron Filtration and **CANNOT** be run dry.

DRIVEN

TT-2600CM

RADIAL GEARED-UP 1:4 DRIVEN TOOL REDIRECTED IN Z BY 80mm

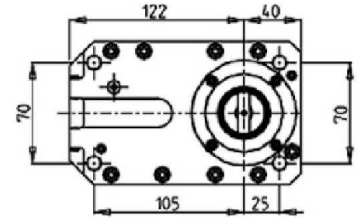
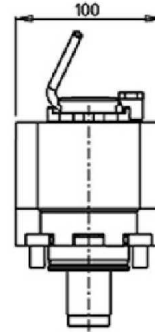
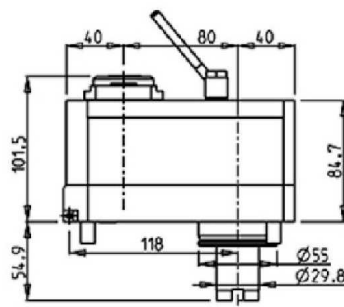

PartNumber	Description	Spindle	I	RPM	Ext Cool
TKW0610120	Radial Geared-Up 1:4 Redirected ER20	ER20	1:4	16000	X

DRIVEN

TT-2600CM

AXIAL DRIVEN TOOL H=105mm

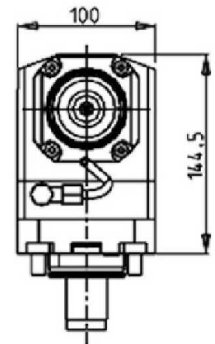
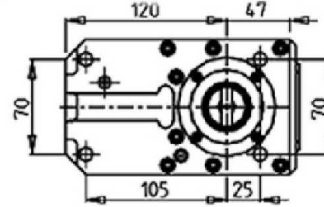
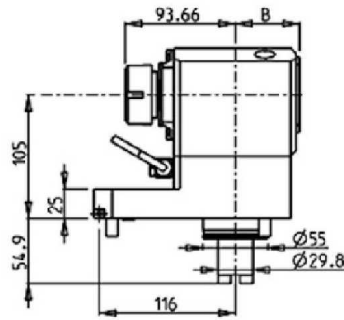

PartNumber	Description	Spindle	I	RPM	Cool Thru	Ext Cool	B
TKW0670132	Axial Driven Tool ER32	ER32	1:1	4000		X	54.5
TKW0670232	Axial Driven Tool ER32 Cool Thru*	ER32	1:1	4000	X	X	67

* Coolant Thru tools are designed for 1000 psi.
They require 5 Micron Filtration and **CANNOT** be run dry.

STATIC

TT-2600CM

RADIAL SINGLE STATIC TOOL

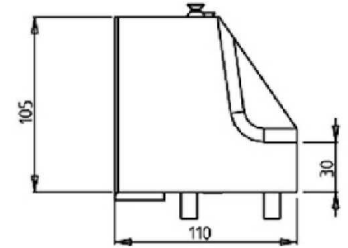
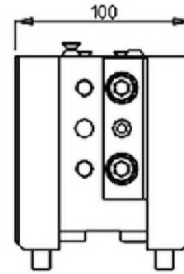
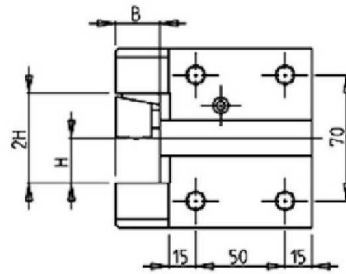
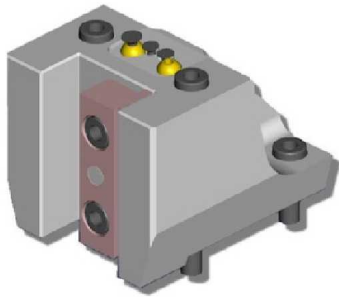

PartNumber	Description	# of Tools	Dimensions	B	H
TKW0682500	Radial Single Static Tool 25mm	1	mm	25	25

AXIAL SINGLE STATIC TOOL

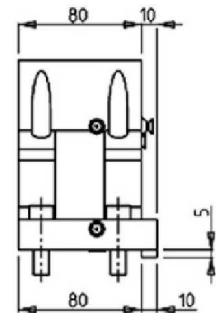
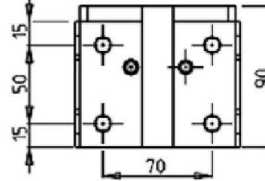
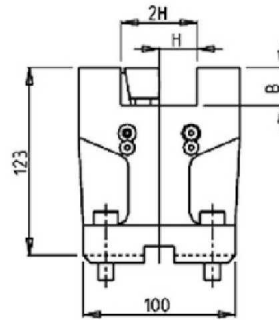
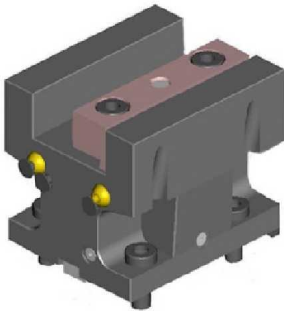

PartNumber	Description	# of Tools	Dimensions	B	H
TKW0692500	Axial Single Static Tool 25mm	1	mm	25	25

STATIC

TT-2600CM

AXIAL SINGLE BORING BAR HOLDER H=110mm

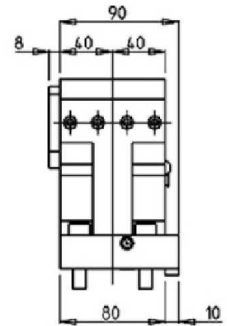
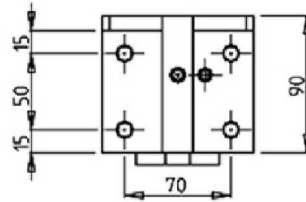
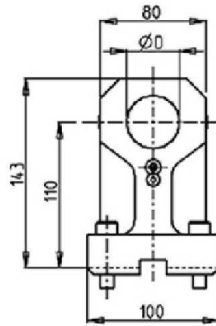
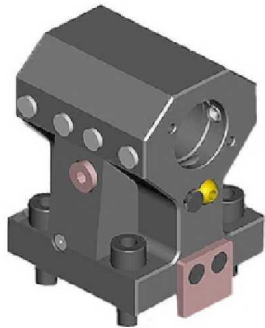

PartNumber	Description	# of Tools	Cool Thru	Ext Cool	Dimensions	D
TKW0704000	Axial Single Boring Bar Holder 40mm	1	X	X	mm	40
KIT1000031	Plug for 40mm BBH to Make Cool Thru*					

AXIAL REAR-SET BORING BAR HOLDER H=110mm

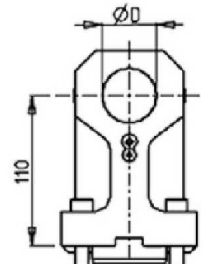
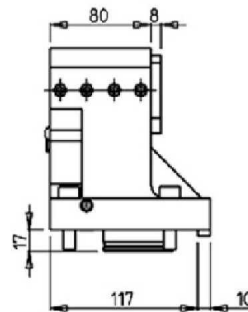
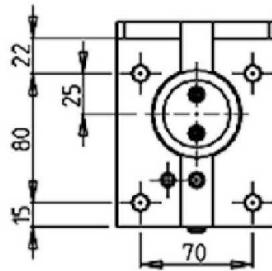
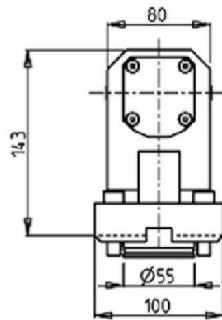

PartNumber	Description	# of Tools	Cool Thru	Ext Cool	Dimensions	D
TKW0784000	Axial Rear-Set Boring Bar Holder 40mm	1	X	X	mm	40
KIT1000031	Plug for 40mm BBH to Make Cool Thru*					

DRIVEN

ACCESSORIES

MTSK-40 ER ADAPTORS

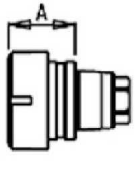

Cod. MT	Mandrino Spindel	A
MTSK40A02	ER32	35.6
MTSK40A03	ER25	32.6
MTSK40A05	ER16	30.26

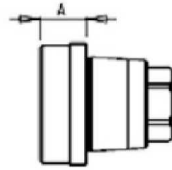

Cod. MT	Mandrino Spindel	A
MTSK40B02	ERA25	16
MTSK40B03	ERA20	14

PartNumber	Description	Spindle	A
MTSK40A05	MTSK-40 Adaptor ER16	ER16	30.26
MTSK40B03	MTSK-40 Adaptor ERA20	ERA20	14
MTSK40A03	MTSK-40 Adaptor ER25	ER25	32.6
MTSK40B02	MTSK-40 Adaptor ERA25	ERA20	16
MTSK40A02	MTSK-40 Adaptor ER32	ER32	35.6

DRIVEN

ACCESSORIES

MTSK-40 MILL ADAPTORS



Cod. MT	Handline Spindle	A
MTSK40D01	WELDON 6	8
MTSK40D21	WELDON 6	27.5
MTSK40D02	WELDON 8	8
MTSK40D03	WELDON 10	9
MTSK40D04	WELDON 12	14
MTSK40D05	WELDON 16	39.5
MTSK40D07	WELDON 20	39.5
MTSK40D24	WELDON 10	33
MTSK40D25	WELDON 12	35.5

Cod. MT	Handline Spindle	A
MTSK40G03	MR25	33.6

Cod. MT	Handline Spindle	Handline Dimensions	A	D	L
MTSK40C03	Ø16x17	inch	15	16	17
MTSK40C02	Ø16x17	inch	15	16	17
MTSK40C04	Ø22x19	mm	17	22	19
MTSK40C05	Ø27x21	mm	22	27	21

Cod. MT	Handline Spindle	A
MTSK40D11	WELDON 1/4"	8
MTSK40D12	WELDON 5/16"	8
MTSK40D13	WELDON 3/8"	9
MTSK40D14	WELDON 1/2"	14

Cod. MT	Handline Spindle	A
MTSK40H01	MORSE-1	29
MTSK40H02	MORSE-2	42

Cod. MT	Handline Spindle	Handline Dimensions	A	D	L
MTSK40T00	Ø 1/2"	inch	32	1/2"	6.5

Cod. MT	Handline Spindle	A
MTSK40T00	Cover Plug	
	Abdeckstopfen	

PartNumber	Description	Spindle	Dimensions	A	D	L
MTSK40C03	MTSK-40 Adaptor Mill 3/4"	3/4"x3/4"	Inch	15.5	3/4"	3/4"
MTSK40C02	MTSK-40 Adaptor Mill Ø16x17	Ø16x17	mm	15	16	17
MTSK40C04	MTSK-40 Adaptor Mill Ø22x19	Ø22x19	mm	17	22	19
MTSK40C05	MTSK-40 Adaptor Mill Ø27x21	Ø27x21	mm	22	27	21
MTSK40F01	MTSK-40 Adaptor Mill 1/2"	1/2" Arbor	Inch	32	1/2"	6.5
MTSK40D11	MTSK-40 Adaptor Mill Weldon 1/4"	Weldon 1/4"		8		
MTSK40D12	MTSK-40 Adaptor Mill Weldon 5/16"	Weldon 5/16"		8		
MTSK40D13	MTSK-40 Adaptor Mill Weldon 3/8"	Weldon 3/8"		9		
MTSK40D14	MTSK-40 Adaptor Mill Weldon 1/2"	Weldon 1/2"		14		
MTSK40D01	MTSK-40 Adaptor Mill Weldon 6	Weldon 6		8		
MTSK40D21	MTSK-40 Adaptor Mill Weldon 6	Weldon 6		27.5		
MTSK40D02	MTSK-40 Adaptor Mill Weldon 8	Weldon 8		8		
MTSK40D03	MTSK-40 Adaptor Mill Weldon 10	Weldon 10		9		
MTSK40D24	MTSK-40 Adaptor Mill Weldon 10	Weldon 10		33		
MTSK40D04	MTSK-40 Adaptor Mill Weldon 12	Weldon 12		14		
MTSK40D25	MTSK-40 Adaptor Mill Weldon 12	Weldon 12		35.5		
MTSK40D06	MTSK-40 Adaptor Mill Weldon 16	Weldon 16		39.5		
MTSK40D07	MTSK-40 Adaptor Mill Weldon 20	Weldon 20		39.5		
MTSK40H01	MTSK-40 Adaptor Morse 1	MORSE-1		29		
MTSK40H02	MTSK-40 Adaptor Morse 2	MORSE-2		42		
MTSK40G03	MTSK-40 Adaptor MR25	MR25		33.6		
MTSK40T00	MTSK-40 Cover Plug					

DRIVEN

ACCESSORIES

MTSK-50 ER ADAPTORS

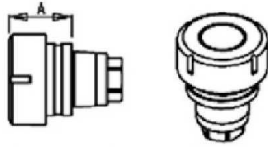

Cod. MT	Mandrina Spindel	A
MTSK50A01	ER40	46.6
MTSK50A02	ER32	35.6
MTSK50A03	ER25	32.6
MTSK50A05	ER16	30.3

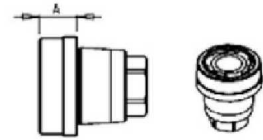

Cod. MT	Mandrina Spindel	A
MTSK50B01	ERA32	19
MTSK50B02	ERA25	14
MTSK50B03	ERA20	9

PartNumber	Description	Spindle	A
MTSK50A05	MTSK-50 Adaptor ER16	ER16	30.3
MTSK50B03	MTSK-50 Adaptor ERA20	ERA20	9
MTSK50A03	MTSK-50 Adaptor ER25	ER25	32.6
MTSK50B02	MTSK-50 Adaptor ERA25	ERA25	14
MTSK50A02	MTSK-50 Adaptor ER32	ER32	35.6
MTSK50B01	MTSK-50 Adaptor ERA32	ERA32	19
MTSK50A01	MTSK-50 Adaptor ER40	ER40	46.6

DRIVEN

ACCESSORIES

MTSK-50 MILL ADAPTORS

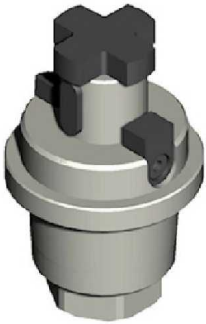

Cod. MT	Manifino Spindle	Manifino Spindle	A	D	L
MTSK50C02	Ø16x17	mm	15	16	17
MTSK50C03	Ø 3/4" x3/4"	Inch	15.5	3/4"	3/4"
MTSK50C04	Ø22x19	mm	17	22	19
MTSK50C05	Ø1" x3/4"	Inch	19	1"	3/4"
MTSK50C06	Ø27x21	mm	19	27	21
MTSK50C07	Ø32x24	mm	24	32	24

Cod. MT	Manifino Spindle	A
MTSK50D11	WELDON 1/4"	8
MTSK50D12	WELDON 5/16"	8
MTSK50D13	WELDON 3/8"	8
MTSK50D14	WELDON 1/2"	9
MTSK50D15	WELDON 5/8"	12

Cod. MT	Manifino Spindle	A
MTSK50D01	WELDON 6	8
MTSK50D02	WELDON 8	8
MTSK50D03	WELDON 10	8
MTSK50D04	WELDON 12	9
MTSK50D05	WELDON 16	12
MTSK50D07	WELDON 20	40
MTSK50D08	WELDON 25	44

Cod. MT	Manifino Spindle	A
MTSK50E01	POWERGRIP PG25	40

Cod. MT	Manifino Spindle	A
MTSK50T00	Toppe di protezione Cover Plug Abbrivestooler	

PartNumber	Description	Spindle	Dimensions	A	D	L
MTSK50C03	MTSK-50 Adaptor Mill 3/4"	3/4"x3/4"	Inch	15.5	3/4"	3/4"
MTSK50C05	MTSK-50 Adaptor Mill 1"x3/4"	1"x3/4"	Inch	19	1"	3/4"
MTSK50C02	MTSK-50 Adaptor Mill Ø16x17	Ø16x17	mm	15	16	17
MTSK50C04	MTSK-50 Adaptor Mill Ø22x19	Ø22x19	mm	17	22	19
MTSK50C06	MTSK-50 Adaptor Mill Ø27x21	Ø27x21	mm	19	27	21
MTSK50C07	MTSK-50 Adaptor Mill Ø32x24	Ø32x24	mm	24	32	24
MTSK50D11	MTSK-50 Adaptor Mill Weldon 1/4"	Weldon 1/4"		8		
MTSK50D12	MTSK-50 Adaptor Mill Weldon 5/16"	Weldon 5/16"		8		
MTSK50D13	MTSK-50 Adaptor Mill Weldon 3/8"	Weldon 3/8"		8		
MTSK50D14	MTSK-50 Adaptor Mill Weldon 1/2"	Weldon 1/2"		9		
MTSK50D15	MTSK-50 Adaptor Mill Weldon 5/8"	Weldon 5/8"		12		
MTSK50D01	MTSK-50 Adaptor Mill Weldon 6	Weldon 6		8		
MTSK50D02	MTSK-50 Adaptor Mill Weldon 8	Weldon 8		8		
MTSK50D03	MTSK-50 Adaptor Mill Weldon 10	Weldon 10		8		
MTSK50D04	MTSK-50 Adaptor Mill Weldon 12	Weldon 12		9		
MTSK50D05	MTSK-50 Adaptor Mill Weldon 16	Weldon 16		12		
MTSK50D07	MTSK-50 Adaptor Mill Weldon 20	Weldon 20		40		
MTSK50D08	MTSK-50 Adaptor Mill Weldon 25	Weldon 25		44		
MTSK50E01	MTSK-50 Adaptor POWERGRIP PG25	POWERGRIP PG25		40		
MTSK50T00	MTSK-50 Cover Plug					

DRIVEN

ACCESSORIES

POLYGON MAKING MILL HEAD (3 INSERTS)

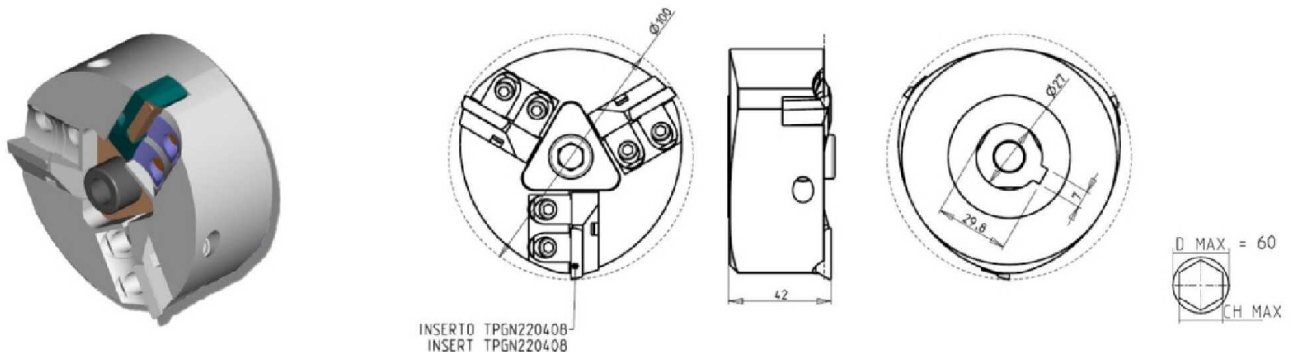

PartNumber	Description
P01Z30A100	3 Insert Polygon Making Mill Head (with Inserts)
TPGN220408	10 Inserts for Polygon Making Mill Heads

POLYGON MAKING MILL HEAD (2 INSERTS)

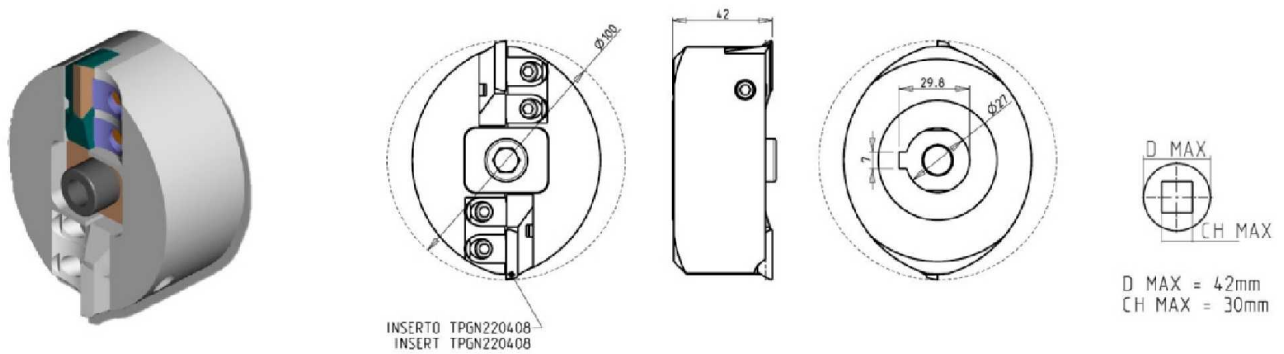

PartNumber	Description
P01Z20A100	2 Insert Polygon Making Mill Head (with Inserts)
TPGN220408	10 Inserts for Polygon Making Mill Heads

ER COLLETS

ER COLLET NUMBER	DESCRIPTION	MD LIST PRICE
ER20 SET	ER20 Collet Set (15 Collets)	\$ 330.00
ERX20 SET	ER20 Sealed Collet Set (13 Collets)	\$ 395.00
ER25 SET	ER25 Collet Set (19 Collets)	\$ 375.00
ERX25 SET	ER25 Sealed Collet Set (17 Collets)	\$ 475.00
ER32 SET	ER32 Collet Set (21 Collets)	\$ 425.00
ERX32 SET	ER32 Sealed Collet Set (21 Collets)	\$ 595.00
ER40 SET	ER40 Collet Set (29 Collets)	\$ 695.00
ERX40 SET	ER40 Sealed Collet Set (27 Collets)	\$ 850.00



Phone: (810) 632-4446 / Fax: (810) 632-4467

Table of Contents

Alphabetized Listing

(
(0-180) ADJUSTABLE ANGLE DRIVEN TOOL	39	AXIAL REAR-SET DRIVEN TOOL		58	
(0-180) ADJUSTABLE ANGLE DRIVEN TOOL GEARED-UP 1:2 H=70mm	4	AXIAL REAR-SET DRIVEN TOOL FOR MAIN SPINDLE		11	
(0-180) ADJUSTABLE ANGLE DRIVEN TOOL GEARED-UP 1:2 WITH DIGITAL DISPLAY H=70mm	4	AXIAL REAR-SET DRIVEN TOOL FOR SUPSPINDLE		11	
(0-180) ADJUSTABLE ANGLE DRIVEN TOOL H=65mm	15	AXIAL SINGLE BORING BAR HOLDER 60mm H=110mm		78	
(0-180) ADJUSTABLE ANGLE DRIVEN TOOL H=70mm	3, 31	AXIAL SINGLE BORING BAR HOLDER 80mm H=110mm		79	
(0-180) ADJUSTABLE ANGLE DRIVEN TOOL WITH DIGITAL DISPLAY	39	AXIAL SINGLE BORING BAR HOLDER H=110mm		93	
(0-180) ADJUSTABLE ANGLE DRIVEN TOOL WITH DIGITAL DISPLAY H=65mm	15	AXIAL SINGLE BORING BAR HOLDER H=80mm		78	
(0-180) ADJUSTABLE ANGLE DRIVEN TOOL WITH DIGITAL DISPLAY H=70mm	3	AXIAL SINGLE BORING BAR HOLDER H=80mm		78	
(0-180) ADJUSTABLE ANGLE GEARED-UP 1:2 DRIVEN TOOL	40	AXIAL SINGLE BORING BAR HOLDER H=90mm		6, 45	
(0-180) ADJUSTABLE ANGLE GEARED-UP 1:2 DRIVEN TOOL WITH DIGITAL DISPLAY	40	AXIAL SINGLE EXTENDED BORING BAR HOLDER 40mm H=115mm		79	
±		AXIAL SINGLE EXTENDED BORING BAR HOLDER H=80mm		79	
±45° Y AXIS ADJUSTABLE ANGLE DRIVEN TOOL	71	AXIAL SINGLE SIDE TWIN HEAD DRIVEN TOOL IN Y		38, 64	
0		AXIAL SINGLE SIDE TWIN HEAD DRIVEN TOOL IN Y FOR INTERNAL POLYGON-MAKING H=90mm		61	
0-180° ADJUSTABLE ANGLE DRIVEN TOOL	66	AXIAL SINGLE SIDE TWIN HEAD DRIVEN TOOL IN Y FOR MAIN SPINDLE		14	
0-180° ADJUSTABLE ANGLE DRIVEN TOOL	65	AXIAL SINGLE SIDE TWIN HEAD DRIVEN TOOL IN Y FOR SUBSPINDLE		14	
0-180° ADJUSTABLE ANGLE DRIVEN TOOL	67	AXIAL SINGLE STATIC TOOL		6, 18, 45, 77, 92	
0-180° ADJUSTABLE ANGLE DRIVEN TOOL WITH DIGITAL DISPLAY	65	AXIAL SINGLE STATIC TOOL - CAPTO		87	
0-180° ADJUSTABLE ANGLE DRIVEN TOOL WITH DIGITAL DISPLAY	66	AXIAL SINGLE STATIC TOOL - CAPTO C6		87	
0-180° ADJUSTABLE ANGLE GEARED-UP 1:2 DRIVEN TOOL	67	AXIAL SINGLE STATIC TOOL - LOWER HEIGHT		77	
0-180° ADJUSTABLE ANGLE GEARED-UP 1:2 DRIVEN TOOL WITH DIGITAL DISPLAY	68	AXIAL SINGLE STATIC TOOL CAPTO C4		19	
A		B			
ACCESSORIES	94-98	BROACHING/SLOTTING DRIVEN TOOL 25mm STROKE H=90mm		16	
AXIAL 2 + 2 POSITION BORING BAR HOLDER	80	BROACHING/SLOTTING DRIVEN TOOL 25mm STROKE H=94mm		72	
AXIAL 3 + 3 POSITION BORING BAR HOLDER	81	BROACHING/SLOTTING DRIVEN TOOL 50mm STROKE H=90mm		16	
AXIAL 3 + 3 POSITION UPRIGHT BORING BAR HOLDER	80	BROACHING/SLOTTING DRIVEN TOOL 50mm STROKE H=94mm		72	
AXIAL 3 POSITION UPRIGHT REAR SET BORING BAR HOLDER	80	C			
AXIAL 4 + 4 POSITION BORING BAR HOLDER	81	CAPTO DRIVEN		83-84	
AXIAL 8 POSITION BORING BAR HOLDER	81	CAPTO STATIC		85-88	
AXIAL DOUBLE BORING BAR HOLDER	18, 46	D			
AXIAL DRIVEN TOOL	2, 31, 34, 37, 57, 59	DRIVEN		1-4, 7-16, 20-41, 47-72, 89-91, 94-98	
AXIAL DRIVEN TOOL CAPTO	84	DRIVEN GEAR HOBBER		41, 69	
AXIAL DRIVEN TOOL FOR MAIN SPINDLE	9	DRIVEN GEAR HOBBER VDI40		28	
AXIAL DRIVEN TOOL FOR MAIN SPINDLE VDI40	21	E			
AXIAL DRIVEN TOOL FOR MAIN SPINDLE VDI40	22	EX308/310 - NEX108/110 - LA200/250 M/Y - LA250YS 15ST.		18	
AXIAL DRIVEN TOOL FOR SUBSPINDLE	10	EX308/310/508/510/708/710/910 - TC350MC - NEX108/110/908/910 LA200/250 M/Y - LA250YS 15ST. - FX-800 - EX2000M/Y		11	
AXIAL DRIVEN TOOL FOR SUBSPINDLE VDI40	23	EX308/310/508/510/708/710/910 - TC350MC - TT350MC NEX108/110/908/910 - LA200/250 M/Y - LA250YS 15ST. - FX-800 - MX-800 - VTL450M - EX2000M/Y - LX2500M		7, 15, 17-19	
AXIAL DRIVEN TOOL FOR SUBSPINDLE VDI40	25	EX308/310/508/510/708/710/910 - TC350MC - TT350MC NEX108/110/908/910 - LA200/250 M/Y - LA250YS 15ST. - FX-800 - VTL450M - EX2000M/Y - LX2500M		7, 9, 12, 16, 19	
AXIAL DRIVEN TOOL H=105mm	91	EX308/310/508/510/708/710/910 - TT350MC - NEX908/910 - LA250YS 15ST. - FX-800 - MX-800 - EX2000M/Y		8, 10-13	
AXIAL GEARED-DOWN 2:1 DRIVEN TOOL	60	EX708/710/910 - NEX108/110/908/910 - LA200/250Y - LA250YS 15ST. - FX-800 - EX2000Y		14, 17	
AXIAL GEARED-DOWN 2:1 OPPOSITE FACE TWIN DRIVEN TOOL	62	EX708/710/910 - NEX108/110/908/910 - LA200/250Y - LA250YS 15ST. - FX-800 - MX-800 - EX2000Y		8, 14	
AXIAL GEARED-UP 1:2 DRIVEN TOOL	60-61	G			
AXIAL GEARED-UP 1:2 DRIVEN TOOL FOR MAIN SPINDLE	12	GEAR HOBBER - HEAVY DUTY TOOL		69	
AXIAL GEARED-UP 1:2 DRIVEN TOOL FOR SUBSPINDLE	12	L			
AXIAL GEARED-UP 1:2 OPPOSITE FACE TWIN DRIVEN TOOL	63	LARGE DRIVEN GEAR HOBBER		70	
AXIAL GEARED-UP 1:3 DRIVEN TOOL FOR MAIN SPINDLE VDI40 H=90mm	27	M			
AXIAL GEARED-UP 1:3 DRIVEN TOOL FOR SUBSPINDLE VDI40 H=90mm	27	MTSK-40 ER ADAPTORS		94	
AXIAL MTSK DRIVEN TOOL FOR INTERNAL POLYGON-MAKING H=90mm	61	MTSK-40 MILL ADAPTORS		95	
AXIAL MULTIPLE 4/8 OUTLET HEAD DRIVEN TOOL	64	MTSK-50 ER ADAPTORS		96	
AXIAL OPPOSITE FACE BORING BAR HOLDER H=90mm	46	MTSK-50 MILL ADAPTORS		97	
AXIAL OPPOSITE FACE DRIVEN TOOL	2, 34, 38	N			
AXIAL OPPOSITE FACE TWIN DRIVEN TOOL	13	NEX315/715 - LS800M - VTL750M - LA350M - LA250YS 12ST.		29-32	
AXIAL OPPOSITE FACE TWIN DRIVEN TOOL	62				
AXIAL OPPOSITE FACE TWIN DRIVEN TOOL CAPTO	84				
AXIAL OPPOSITE FACE TWIN STATIC TOOL - CAPTO	88				
AXIAL REAR-SET BORING BAR HOLDER H=110mm	93				
AXIAL REAR-SET BORING SINGLE STATIC TOOL - CAPTO	88				

Table of Contents

Alphabetized Listing

P			
Please see Accessories for MTSK Clamping Units	9-10, 21, 23-24, 26, 35, 37, 48-52, 58, 61-62, 70		
POLYGON MAKING MILL HEAD (2 INSERTS)	98	RADIAL SINGLE STATIC TOOL	5, 42, 73, 92
POLYGON MAKING MILL HEAD (3 INSERTS)	98	RADIAL SINGLE STATIC TOOL	73
Q		RADIAL SINGLE STATIC TOOL	73
QUICK CHANGE AXIAL MTSK DRIVEN TOOL	37, 58	RADIAL SINGLE STATIC TOOL - CAPTO	85
QUICK CHANGE AXIAL MTSK DRIVEN TOOL	59	RADIAL SINGLE STATIC TOOL CAPTO C4	19
QUICK CHANGE AXIAL MTSK DRIVEN TOOL FOR MAIN SPINDLE	9	RADIAL SINGLE STATIC TOOL H=75mm	17
QUICK CHANGE AXIAL MTSK DRIVEN TOOL FOR MAIN SPINDLE VDI40	23	REINFORCED DRIVEN GEAR HOBBER	32
QUICK CHANGE AXIAL MTSK DRIVEN TOOL FOR MAIN SPINDLE VDI40	21	S	
QUICK CHANGE AXIAL MTSK DRIVEN TOOL FOR POWER SKIVING H=106mm	70	See Accessories for Polygon Making Mill Heads	61
QUICK CHANGE AXIAL MTSK DRIVEN TOOL FOR SUBSPINDLE	10	STATIC	5-6, 17-19, 42-46, 73-82, 92-93
QUICK CHANGE AXIAL MTSK DRIVEN TOOL FOR SUBSPINDLE VDI40	26	T	
QUICK CHANGE AXIAL MTSK DRIVEN TOOL FOR SUBSPINDLE VDI40	24	TAILSTOCK FOR SUB-SPINDLE	82
QUICK CHANGE AXIAL MTSK OPPOSITE FACE TWIN DRIVEN TOOL	62	TCY160/200	1-6
QUICK CHANGE RADIAL MTSK DRIVEN TOOL	35, 48	TMM200/250 - TNR200	20-28
QUICK CHANGE RADIAL MTSK DRIVEN TOOL HIGH PRESSURE	49	TS3000/4000/5000 Y/YS 12 ST. (3 KEYS TURRET)	47-88
QUICK CHANGE RADIAL MTSK DRIVEN TOOL REDIRECTED IN Z BY 45mm	51	TS3000/4000/5000 Y/YS 15 ST. - TM4000 12ST.	35-46
QUICK CHANGE RADIAL MTSK GEARED-DOWN 2:1 DRIVEN TOOL REDIRECTED IN Z BY 45mm	52	TT-2600CM	89-93
QUICK CHANGE RADIAL MTSK REINFORCED DRIVEN TOOL	50	TY2000Y/YS/CS	33-34
R		W	
RADIAL ±25° ADJUSTABLE ANGLE DRIVEN TOOL REDIRECTED BY 50mm	56	WORM GEAR DRIVEN TOOL	71
RADIAL 6 HEAD DRIVEN TOOL	55		
RADIAL BLADE HOLDER WITH BLADE KIT	5, 44		
RADIAL BLADE HOLDER WITH INTERNAL COOLANT-BLADE KIT NOT INCLUDED	44		
RADIAL DOUBLE 2+2 UPRIGHT POSITION STATIC TOOL - CAPTO	86		
RADIAL DOUBLE 3+3 UPRIGHT POSITION STATIC TOOL - CAPTO	86		
RADIAL DOUBLE BLADE HOLDER WITH BLADE KIT	76		
RADIAL DOUBLE BLADE HOLDER WITH INTERNAL COOLANT- BLADE KIT NOT INCLUDED	76		
RADIAL DOUBLE SIDE TWIN STATIC TOOL	75		
RADIAL DOUBLE STATIC TOOL	5, 43, 75		
RADIAL DOUBLE STATIC TOOL - CAPTO	85		
RADIAL DOUBLE TWIN SIDE BLADE HOLDER WITH BLADE KIT	76		
RADIAL DRIVEN TOOL	1, 7, 29, 33, 35, 47		
RADIAL DRIVEN TOOL CAPTO	83		
RADIAL DRIVEN TOOL HIGH PRESSURE	29, 48		
RADIAL DRIVEN TOOL REDIRECTED IN Z BY 45mm	50		
RADIAL DRIVEN TOOL REDIRECTED IN Z BY 80mm	89		
RADIAL DRIVEN TOOL VDI40	20		
RADIAL GEARED-DOWN 2:1 DRIVEN TOOL REDIRECTED IN Z BY 45mm	51		
RADIAL GEARED-DOWN 2:1 DRIVEN TOOL REDIRECTED IN Z BY 80mm	89		
RADIAL GEARED-UP 1:2 DRIVEN TOOL FOR SUBSPINDLE REDIRECTED IN Z BY 70mm	8		
RADIAL GEARED-UP 1:2 DRIVEN TOOL REDIRECTED IN Z BY 45mm	52		
RADIAL GEARED-UP 1:2 DRIVEN TOOL RE-DIRECTED IN Z BY 50mm	1		
RADIAL GEARED-UP 1:2 DRIVEN TOOL REDIRECTED IN Z BY 70mm	7		
RADIAL GEARED-UP 1:4 DRIVEN TOOL REDIRECTED IN Z BY 80mm	90		
RADIAL GEARED-UP 1:5 DRIVEN TOOL	53		
RADIAL INVERTED DRIVEN TOOL REDIRECTED IN Z	55		
RADIAL INVERTED DRIVEN TOOL REDIRECTED IN Z BY 180mm	30		
RADIAL REAR-SET SINGLE STATIC TOOL	42, 74		
RADIAL REINFORCED MILLING TOOL	49		
RADIAL SINGLE SIDE TWIN HEAD DRIVEN TOOL FOR Y-AXIS	54		
RADIAL SINGLE SIDE TWIN HEAD DRIVEN TOOL FOR Z-AXIS	54		
RADIAL SINGLE SIDE TWIN HEAD DRIVEN TOOL IN Y	8, 33, 36		
RADIAL SINGLE SIDE TWIN STATIC TOOL	17, 43, 74		

Table of Contents

Part Number Index

B			MNL0021632	Radial ER32 Ext. Reach Cool Thru*	47
BLADEKIT	Blade Kit: 1 Blade, 10 Inserts	5	MNL0022132	Radial ER32 Short	47
BLADEKIT	Blade Kit: 1 Blade, 10 Inserts	44	MNL0022140	Radial ER40 Short	47
BLADEKIT	Blade Kit: 1 Blade, 10 Inserts	76	MNL0022219	Radial Mill Head 22x19mm	47
BLADEKIT-2	Blade Kit: 2 Blade, 20 Inserts	76	MNL0022519	Radial Mill Head 1"x19mm	47
			MNL0022721	Radial Mill Head 27x21mm	47
C			MNL0041905	Radial Single Static 3/4"	73
COOL THRU	Blade Kit: 1 Blade, 10 Inserts	76	MNL0042000	Radial Single Static 20mm	73
BLADEKIT			MNL0042000_CH	Radial Single Static 20mm	73
COOL THRU	Blade Kit: 1 Blade, 10 Inserts	44	MNL0042500	Radial Single Static 25mm	73
BLADEKIT			MNL0042500_CH	Radial Single Static 25mm	73
			MNL0042510	Radial Single Static 25mm Cool Thru*	73
K			MNL0042540	Radial Single Static 1"	73
KIT1000001	Plug for 32mm BBH to Make Cool Thru	6	MNL0043175	Radial Single Static 1-1/4"	73
KIT1000001	32mm or 1-1/4" Plug to Make BBH Cool Thru*	18	MNL0043200	Radial Single Static 32mm	73
KIT1000001	32mm or 1-1/4" Plug to Make BBH Cool Thru*	80	MNL0051905	Radial Double Static Tool 3/4"	75
KIT1000001	32mm or 1-1/4" Plug to Make BBH Cool Thru*	81	MNL0052000	Radial Double Static Tool 20mm	75
KIT1000003	40mm Plug & Seal to Make BBH Cool Thru*	79	MNL0052500	Radial Double Static Tool 25mm	75
KIT1000006	25mm or 1" Plug to Make BBH Cool Thru*	80	MNL0052540	Radial Double Static Tool 1"	75
KIT1000006	25mm or 1" Plug to Make BBH Cool Thru*	18	MNL0061905	Radial Single Side Double Tool 3/4"	74
KIT1000006	25mm or 1" Plug to Make BBH Cool Thru*	46	MNL0062000	Radial Single Side Double Tool 20mm	74
KIT1000015	20mm Plug to Make BBH Cool Thru*	18	MNL0062500	Radial Single Side Double Tool 25mm	74
KIT1000031	Plug for 40mm BBH to Make Cool Thru*	45	MNL0062540	Radial Single Side Double Tool 1"	74
KIT1000031	Plug for 40mm BBH to Make Cool Thru*	46	MNL0071905	Radial Double Side Twin Static Tool 3/4"	75
KIT1000031	Plug for 40mm BBH to Make Cool Thru*	93	MNL0072000	Radial Double Side Twin Static Tool 20mm	75
KIT1000031	Plug for 40mm BBH to Make Cool Thru*	93	MNL0072500	Radial Double Side Twin Static Tool 25mm	75
KIT1001002	50mm or 2" Plug & Seal to Make BBH Cool Thru*	78	MNL0072540	Radial Double Side Twin Static Tool 1"	75
KIT1002003	40mm Plug & Seal to Make BBH Cool Thru*	79	MNL0082500	Axial 4+4 Boring Bar Holder 25mm	81
KIT1002004	1-1/2" Plug & Seal to Make BBH Cool Thru*	79	MNL0082540	Axial 4+4 Boring Bar Holder 1"	81
KIT1003003	40mm Plug & Seal to Make BBH Cool Thru*	78	MNL0093175	Axial 3+3 Boring Bar Holder 1-1/4"	81
KIT1003004	1 1/2" Plug & Seal to Make BBH Cool Thru*	78	MNL0093200	Axial 3+3 Boring Bar Holder 32mm	81
KIT1005013	80mm Plug & Seal to Make BBH Cool Thru*	79	MNL0103175	Axial 2+2 Boring Bar Holder 1-1/4"	80
KIT1005025	60mm Plug & Seal to Make BBH Cool Thru*	78	MNL0103200	Axial 2+2 Boring Bar Holder 32mm	80
M			MNL0113810	Axial Single Boring Bar Holder 1-1/2"	78
MNL0010120	Axial Weldon 20	57	MNL0114000	Axial Single Boring Bar Holder 40mm	78
MNL0010125	Axial Weldon 25	57	MNL0115000	Axial Single Boring Bar Holder 50mm	78
MNL0010132	Axial Weldon 32	57	MNL0115080	Axial Single Boring Bar Holder 2"	78
MNL0010140	Axial ER40	57	MNL0121905	Axial 8-Position Boring Bar Holder 3/4"	81
MNL0010220	Axial Weldon 20 Cool Thru*	57	MNL0122000	Axial 8-Position Boring Bar Holder 20mm	81
MNL0010225	Axial Weldon 25 Cool Thru*	57	MNL0131905	Axial Single Position Tool 3/4"	77
MNL0010332	Axial ERA32	57	MNL0132000	Axial Single Position Tool 20mm	77
MNL0010432	Axial ERA32 Cool Thru*	57	MNL0132500	Axial Single Position Tool 25mm	77
MNL0010525	Axial ER25	57	MNL0132540	Axial Single Position Tool 1"	77
MNL0010532	Axial ER32	57	MNL0140132	Radial Double Blade Holder wth Blade Kit	76
MNL0011140	Axial ER40 Cool Thru*	57	MNL0151100	Gear Hobbing Tool 1:1	69
MNL0011525	Axial ER25 Cool Thru*	57	MNL0152100	Gear Hobbing Tool 2:1 Geared Down	69
MNL0011532	Axial ER32 Cool Thru*	57	MNL0160232	Radial Double Twin-Side Blade Holder with Blade Kit	76
MNL0011617	Axial Mill Head 16x17mm	57			
MNL0012219	Axial Mill Head 22x19mm	57	MNL0182500	Axial 3+3 Boring Bar Holder 25mm	80
MNL0012519	Axial Mill Head 1"x19mm	57	MNL0182540	Axial 3+3 Boring Bar Holder 1"	80
MNL0012721	Axial Mill Head 27x21mm	57	MNL0192500	Axial Triple Rear-Set Boring Bar Holder 25mm	80
MNL0020116	Radial Mill Head 16x17mm Cool Thru*	47	MNL0192540	Axial Triple Rear-Set Boring Bar Holder 1"	80
MNL0020120	Radial Weldon 20	47	MNL0200225	Radial Single Side Twin Driven Tool ER25	54
MNL0020122	Radial Mill Head 22x19mm Cool Thru*	47	MNL0201225	Radial Single Side Twin Driven Tool ER25 Cool Thru*	54
MNL0020125	Radial Weldon 25	47			
MNL0020132	Radial Weldon 32	47	MNL0201325	Radial Single Side Twin Driven Tool ERA25 Cool Thru*	54
MNL0020140	Radial ER40 Standard	47			
MNL0020220	Radial Weldon 20 Cool Thru*	47	MNL0210625	Radial 6 Head Driven Tool ER25	55
MNL0020232	Radial Weldon 32 Cool Thru*	47	MNL0220225	Axial Double Outlet ER25	64
MNL0020425	Radial Weldon 25 Cool Thru*	47	MNL0221225	Axial Double Outlet ER25 Cool Thru*	64
MNL0020525	Radial Mill Head 1"x19mm Cool Thru*	47	MNL0221325	Axial Double Outlet ERA25 Cool Thru*	64
MNL0020532	Radial ER32 Standard	47	MNL0230425	Axial Four Outlet ER25 Tool	64
MNL0020632	Radial ER32 Extended Reach	47	MNL0234425	Axial 4+4 Outlet ER25 Tool	64
MNL0020732	Radial ER32 Cool Thru*	47	MNL0290632	Axial ER32 Rear-Set Driven Tool	58
MNL0021140	Radial ER40 Cool Thru*	47	MNL0291632	Axial ER32 Rear-Set Driven Tool Cool Thru*	58
MNL0021532	Radial ER32 Cool Thru*	47	MNL0302000	Axial Single Static Tool - Lower Height 20mm	77
MNL0021617	Radial Mill Head 16x17mm	47	MNL0302500	Axial Single Static Tool - Lower Height 25mm	77

Table of Contents

Part Number Index

MNL0313810	Axial Single Extended BBH 1-1/2"	79	MNL0483240LC	Radial Double 2+2 Static Tool: Left C3 Capto	86
MNL0314000	Axial Single Extended BBH 40mm	79	MNL0483260	Radial Double 3+3 Static Tool: Right C3 Capto	86
MNL0330120	Axial Geared-Down 2:1 Weldon20	60	MNL0483260LC	Radial Double 3+3 Static Tool: Left C3 Capto	86
MNL0330125	Axial Geared-Down 2:1 Weldon25	60	MNL0494010	Axial Single Static Tool: Right C4 Capto	87
MNL0330132	Axial Geared-Down 2:1 Weldon32	60	MNL0494010LC	Axial Single Static Tool: Left C4 Capto	87
MNL0330140	Axial Geared-Down 2:1 ER40	60	MNL0495010	Axial Single Static Tool: Right C5 Capto	87
MNL0330220	Axial Geared-Down 2:1 Weldon20 Cool Thru*	60	MNL0495010LC	Axial Single Static Tool: Left C5 Capto	87
MNL0330225	Axial Geared-Down 2:1 Weldon25 Cool Thru*	60	MNL0495015	Axial Single Static Tool: Right C5 Capto	87
MNL0330232	Axial Geared-Down 2:1 Weldon32 Cool Thru*	60	MNL0495015LC	Axial Single Static Tool: Left C5 Capto	87
MNL0330525	Axial Geared-Down 2:1 ER25	60	MNL0496010	Axial Single Static Tool: Right C6 Capto	87
MNL0330532	Axial Geared-Down 2:1 ER32	60	MNL0496010LC	Axial Single Static Tool: Left C6 Capto	87
MNL0331140	Axial Geared-Down 2:1 ER40 Cool Thru*	60	MNL0504020	Axial Opposite Face Twin Static Tool: Right C4 Capto	88
MNL0331525	Axial Geared-Down 2:1 ER25 Cool Thru*	60	MNL0504020LC	Axial Opposite Face Twin Static Tool: Left C4 Capto	88
MNL0331532	Axial Geared-Down 2:1 ER32 Cool Thru*	60	MNL0514010	Axial Rear-Set Boring Static Tool: Right C4 Capto	88
MNL0331617	Axial Geared-Down 2:1 Mill Head 16x17mm	60	MNL0514010LC	Axial Rear-Set Boring Static Tool: Left C4 Capto	88
MNL0332219	Axial Geared-Down 2:1 Mill Head 22x19mm	60	MNL0515010	Axial Rear-Set Boring Static Tool: Right C5 Capto	88
MNL0332519	Axial Geared-Down 2:1 Mill Head 1"x19mm	60	MNL0515010LC	Axial Rear-Set Boring Static Tool: Left C5 Capto	88
MNL0332721	Axial Geared-Down 2:1 Mill Head 27x21mm	60	MNL0520140	Axial Capto C4	84
MNL0340032	Radial Redirected ER32	50	MNL0520150	Axial Capto C5	84
MNL0340120	Radial Redirected ER20	50	MNL0520240	Axial Capto C4 Cool Thru*	84
MNL0340132	Radial Redirected ER32 Cool Thru*	50	MNL0520250	Axial Capto C5 Cool Thru*	84
MNL0340220	Radial Redirected ER20 Cool Thru*	50	MNL0530140	Radial Capto C4	83
MNL0341116	Radial Redirected Mill Head 16x17mm	50	MNL0530150	Radial Capto C5	83
MNL0341119	Radial Redirected Mill Head 3/4"x3/4"	50	MNL0570125	Radial ER25 Cool Thru*	48
MNL0341122	Radial Redirected Mill Head 22x19mm	50	MNL0570132	Radial ER32 Cool Thru*	48
MNL0341127	Radial Redirected Mill Head 27x21mm	50	MNL0580140	Axial MTSK-40	58
MNL0341225	Radial Redirected ER25 Geared-Up 1:2	52	MNL0580150	Axial MTSK-50	58
MNL0342119	Radial Geared-Down 2:1 Mill Head 3/4"x3/4"	51	MNL0580240	Axial MTSK-40 Cool Thru*	58
MNL0342122	Radial Geared-Down 2:1 Mill Head 22x19mm	51	MNL0580250	Axial MTSK-50 Cool Thru*	58
MNL0342125	Radial Geared-Down 2:1 Mill Head 1"x19mm	51	MNL0590150	Radial MTSK-50	48
MNL0342127	Radial Geared-Down 2:1 Mill Head 27x21mm	51	MNL0590250	Radial MTSK-50 Cool Thru*	49
MNL0342132	Radial Geared-Down 2:1 ER32	51	MNL0604000	Axial Single Extended BBH 40mm	79
MNL0342225	Radial Redirected Mill Head 1"x19mm	50	MNL0616000	Single Boring Bar Holder 60mm	78
MNL0342425	Radial Redirected ER25 Geared-Up 1:2 Cool Thru*	52	MNL0628000	Single Boring Bar Holder 80mm	79
MNL0350532	Axial ER32 Geared-Up 1:2	60	MNL0640120	0-180° Adjustable Angle ERA20	66
MNL0351532	Axial ER32 Geared-Up 1:2 Cool Thru*	60	MNL0640220	0-180° Adjustable Angle ERA20 Cool Thru*	66
MNL0360100	Tailstock for Sub-Spindle 38mm	82	MNL0640316	0-180° Adj. Angle Geared-Up 1:2 ERA16	67
MNL0360100L	Tailstock for Sub-Spindle 2"	82	MNL0640416	0-180° Adj. Angle Geared-Up 1:2 ERA16 Cool Thru*	67
MNL0378022	Driven Worm Gear Tool 22mmx17mm	71	MNL0645120	0-180° Adj. Angle with Digital Display ERA20	66
MNL0378125	Driven Worm Gear Tool 1"x12mm	71	MNL0645220	0-180° Adj. Angle with Digital Display ERA20 Cool Thru*	66
MNL0381905	Radial Rear-Set Single Tool 3/4"	74	MNL0645316	0-180° Adj. Angle Geared-Up 1:2 ERA16 with Digital Display	68
MNL0382000	Radial Rear-Set Single Tool 20mm	74	MNL0645416	0-180° Adj. Angle Geared-Up 1:2 ERA16 with Digital Display Cool Thru*	68
MNL0382500	Radial Rear-Set Single Tool 25mm	74	MNL0650100	Broaching / Slotting Tool	72
MNL0382540	Radial Rear-Set Single Tool 1"	74	MNL0650200	Broaching / Slotting Tool	72
MNL0411100	Heavy Duty Gear Hobbing Tool 1:1	69	MNL0660140	0-180° Adjustable Angle ERA40	67
MNL0412100	Heavy Duty Gear Hobbing Tool 2:1 Geared Down	69	MNL0660240	0-180° Adjustable Angle ERA40 Cool Thru*	67
MNL0420225	Radial ER25 Double Outlet Tool for Z-Axis	54	MNL0660332	0-180° Adjustable Angle ERA32	67
MNL0421225	Radial ER25 Double Outlet Tool for Z-Axis Cool Thru*	54	MNL0660432	0-180° Adjustable Angle ERA32 Cool Thru*	67
MNL0421325	Radial ERA25 Double Outlet Tool for Z-Axis Cool Thru*	54	MNL0671100	Large Gear Hobber 1:1	70
MNL0450116	Axial Geared-Up 1:2 Opposite Face ERA16+ERA16	63	MNL0672100	Large Gear Hobber 2:1 Geared Down	70
MNL0450120	Axial Geared-Up 1:2 Opposite Face ERA20+ERA20	63	MNL0690120	Radial Geared-Up 1:5 Driven Tool ERA20	53
MNL0464010	Single Radial Static Tool: Right C4 Capto	85	MNL0732219	Radial Reinforced Driven Tool 22x19mm	49
MNL0464010LC	Single Radial Static Tool: Left C4 Capto	85	MNL0732519	Radial Reinforced Driven Tool 1"x19mm	49
MNL0465010	Single Radial Static Tool: Right C5 Capto	85	MNL0732721	Radial Reinforced Driven Tool 27x21mm	49
MNL0465010LC	Single Radial Static Tool: Left C5 Capto	85	MNL0733224	Radial Reinforced Driven Tool 32x24mm	49
MNL0465015	Single Radial Static Tool: Right C5 Capto	85	MNL0740150	Radial MTSK-50 Reinforced	50
MNL0465015LC	Single Radial Static Tool: Left C5 Capto	85	MNL0830232	Axial Double Outlet ER32/ER32	62
MNL0466010	Single Radial Static Tool: Right C6 Capto	85	MNL0830240	Axial Double Outlet ER40/ER32	62
MNL0466010LC	Single Radial Static Tool: Left C6 Capto	85	MNL0840140	Axial ER40	59
MNL0474020	Radial Double Static Tool: Right C4 Capto	85	MNL0840240	Axial ER40 Cool Thru*	59
MNL0474020LC	Radial Double Static Tool: Left C4 Capto	85	MNL0850140	Axial MTSK-40	59
MNL0475020	Radial Double Static Tool: Right C5 Capto	85	MNL0850150	Axial MTSK-50	59
MNL0475020LC	Radial Double Static Tool: Left C5 Capto	85	MNL0850240	Axial MTSK-40 Cool Thru*	59
MNL0483240	Radial Double 2+2 Static Tool: Right C3 Capto	86			

Table of Contents

Part Number Index

MNL0850250	Axial MTSK-50 Cool Thru*	59	MTSK50C06	MTSK-50 Adaptor Mill Ø27x21	97
MNL0860132	Radial Blade Holder Cool Thru	76	MTSK50C07	MTSK-50 Adaptor Mill Ø32x24	97
MNL0870100	Axial MTSK-40 for Power Skiving	70	MTSK50D01	MTSK-50 Adaptor Mill Weldon 6	97
MNL0890120	0-180° Adj. Angle with Digital Display ER20	65	MTSK50D02	MTSK-50 Adaptor Mill Weldon 8	97
MNL0890125	0-180° Adj. Angle with Digital Display ER25	65	MTSK50D03	MTSK-50 Adaptor Mill Weldon 10	97
MNL0890516	0-180° Adj. Angle with Digital Display Ø16x17mm	65	MTSK50D04	MTSK-50 Adaptor Mill Weldon 12	97
MNL0890519	0-180° Adj. Angle with Digital Display 3/4"x3/4"	65	MTSK50D05	MTSK-50 Adaptor Mill Weldon 16	97
MNL0890522	0-180° Adj. Angle with Digital Display Ø22x19mm	65	MTSK50D07	MTSK-50 Adaptor Mill Weldon 20	97
MNL0900140	Axial MTSK-40 Driven Tool H=90mm	61	MTSK50D08	MTSK-50 Adaptor Mill Weldon 25	97
MNL0914032	Axial Geared-Down 2:1 Opposite Face ER40+ER32	62	MTSK50D11	MTSK-50 Adaptor Mill Weldon 1/4"	97
MNL0930120	0-180° Adjustable Angle ER20	65	MTSK50D12	MTSK-50 Adaptor Mill Weldon 5/16"	97
MNL0930125	0-180° Adjustable Angle ER25	65	MTSK50D13	MTSK-50 Adaptor Mill Weldon 3/8"	97
MNL0930516	0-180° Adjustable Angle Ø16x17mm	65	MTSK50D14	MTSK-50 Adaptor Mill Weldon 1/2"	97
MNL0930519	0-180° Adjustable Angle 3/4"x3/4"	65	MTSK50D15	MTSK-50 Adaptor Mill Weldon 5/8"	97
MNL0930522	0-180° Adjustable Angle Ø22x19mm	65	MTSK50E01	MTSK-50 Adaptor POWERGRIP PG25	97
MNL0940616	Axial Single Side Twin Head Weldon 16	61	MTSK50T00	MTSK-50 Cover Plug	97
MNL0950332	Radial ±25° Adjustable Angle ERA32	56	P		
MNL0961055	Radial Inverted Driven Tool	55	P01Z20A100	2 Insert Polygon Making Mill Head (with Inserts)	98
MNL0961105	Radial Inverted Driven Tool	55	P01Z30A100	3 Insert Polygon Making Mill Head (with Inserts)	98
MNL0961155	Radial Inverted Driven Tool	55	T		
MNL1015040	Axial MTSK Opposite Face Twin Driven Tool	62	TKW0010125	Axial Driven ER25	2
MNL1100125	±45° Y Axis Adjustable Angle ER25	71	TKW0010132	Axial Driven ER32	2
MNL1170240	Axial Opposite Face Capto C4+C4	84	TKW0010140	Axial Driven ER40	2
MNL1196010	Axial Single Static Tool: Right C6 Capto	87	TKW0010225	Axial Driven ER25 Cool Thru*	2
MNL1196010LC	Axial Single Static Tool: Left C6 Capto	87	TKW0010232	Axial Driven ER32 Cool Thru*	2
MNL1210140	Radial Redirected MTSK-40	51	TKW0010240	Axial Driven ER40 Cool Thru*	2
MNL1210240	Radial Redirected MTSK-40 Cool Thru*	51	TKW0010325	Axial Driven ERA25	2
MNL1220140	Radial Geared-Down 2:1 Redirected MTSK-40	52	TKW0010425	Axial Driven ERA25 Cool Thru*	2
MTSK40A02	MTSK-40 Adaptor ER32	94	TKW0010516	Axial Mill Head 16x17	2
MTSK40A03	MTSK-40 Adaptor ER25	94	TKW0010522	Axial Mill Head 22x19	2
MTSK40A05	MTSK-40 Adaptor ER16	94	TKW0010527	Axial Mill Head 27x21	2
MTSK40B02	MTSK-40 Adaptor ERA25	94	TKW0020132	Radial Driven Tool ER32	1
MTSK40B03	MTSK-40 Adaptor ERA20	94	TKW0020432	Radial Driven Tool ERA32 Cool Thru*	1
MTSK40C02	MTSK-40 Adaptor Mill Ø16x17	95	TKW0032520	Axial Opposite Face ERA25+ERA20	2
MTSK40C03	MTSK-40 Adaptor Mill 3/4"	95	TKW0033225	Axial Opposite Face ER32+ER25	2
MTSK40C04	MTSK-40 Adaptor Mill Ø22x19	95	TKW0042500	Radial Single Static Tool 25mm	5
MTSK40C05	MTSK-40 Adaptor Mill Ø27x21	95	TKW0052500	Axial Single Static Tool 25mm	6
MTSK40D01	MTSK-40 Adaptor Mill Weldon 6	95	TKW0063200	Axial Single BBH 32mm	6
MTSK40D02	MTSK-40 Adaptor Mill Weldon 8	95	TKW0070232	Radial Blade Holder with Blade Kit	5
MTSK40D03	MTSK-40 Adaptor Mill Weldon 10	95	TKW0082500	Radial Double Static Tool 25mm	5
MTSK40D04	MTSK-40 Adaptor Mill Weldon 12	95	TKW0090132	Axial VDI40 Driven Tool ER32	21
MTSK40D06	MTSK-40 Adaptor Mill Weldon 16	95	TKW0090140	Axial VDI40 Driven Tool ER40	21
MTSK40D07	MTSK-40 Adaptor Mill Weldon 20	95	TKW0090232	Axial VDI40 Driven Tool ER32 Cool Thru*	21
MTSK40D11	MTSK-40 Adaptor Mill Weldon 1/4"	95	TKW0090240	Axial VDI40 Driven Tool ER40 Cool Thru*	21
MTSK40D12	MTSK-40 Adaptor Mill Weldon 5/16"	95	TKW0091132	Axial VDI40 Driven Tool ER32	23
MTSK40D13	MTSK-40 Adaptor Mill Weldon 3/8"	95	TKW0091140	Axial VDI40 Driven Tool ER40	23
MTSK40D14	MTSK-40 Adaptor Mill Weldon 1/2"	95	TKW0091232	Axial VDI40 Driven Tool ER32 Cool Thru*	23
MTSK40D21	MTSK-40 Adaptor Mill Weldon 6	95	TKW0091240	Axial VDI40 Driven Tool ER40 Cool Thru*	23
MTSK40D24	MTSK-40 Adaptor Mill Weldon 10	95	TKW0100132	Radial Driven VDI40 ER32	20
MTSK40D25	MTSK-40 Adaptor Mill Weldon 12	95	TKW0100432	Radial Driven VDI40 ERA32 Cool Thru*	20
MTSK40F01	MTSK-40 Adaptor Mill 1/2"	95	TKW0110132	Axial Driven Tool ER32	9
MTSK40G03	MTSK-40 Adaptor MR25	95	TKW0110232	Axial Driven Tool ER32 Cool Thru*	9
MTSK40H01	MTSK-40 Adaptor Morse 1	95	TKW0110332	Axial Driven Tool ER32	10
MTSK40H02	MTSK-40 Adaptor Morse 2	95	TKW0110432	Axial Driven Tool ER32 Cool Thru*	10
MTSK40T00	MTSK-40 Cover Plug	95	TKW0110527	Axial Mill Head Ø27x21	9
MTSK50A01	MTSK-50 Adaptor ER40	96	TKW0111527	Axial Mill Head Ø27x21	10
MTSK50A02	MTSK-50 Adaptor ER32	96	TKW0120132	Radial Driven Tool ER32	7
MTSK50A03	MTSK-50 Adaptor ER25	96	TKW0120232	Radial Driven Tool ER32 Cool Thru*	7
MTSK50A05	MTSK-50 Adaptor ER16	96	TKW0120522	Radial Mill Head Ø22x19	7
MTSK50B01	MTSK-50 Adaptor ERA32	96	TKW0120825	Radial Driven Tool Weldon 25 Cool Thru*	7
MTSK50B02	MTSK-50 Adaptor ERA25	96	TKW0130132	Axial Opposite Face ER32+ER25	13
MTSK50B03	MTSK-50 Adaptor ERA20	96	TKW0140125	Axial VDI40 ER25	22
MTSK50C02	MTSK-50 Adaptor Mill Ø16x17	97	TKW0140132	Axial VDI40 ER32	22
MTSK50C03	MTSK-50 Adaptor Mill 3/4"	97	TKW0140140	Axial VDI40 ER40	22
MTSK50C04	MTSK-50 Adaptor Mill Ø22x19	97	TKW0140225	Axial VDI40 ER25 Cool Thru*	22
MTSK50C05	MTSK-50 Adaptor Mill 1"x3/4"	97			

Table of Contents

Part Number Index

TKW0140232	Axial VDI40 ER32 Cool Thru*	22	TKW0420150	Axial MTSK-50 Driven Tool	9
TKW0140240	Axial VDI40 ER40 Cool Thru*	22	TKW0420250	Axial MTSK-50 Driven Tool Cool Thru*	9
TKW0140325	Axial VDI40 ERA25	22	TKW0420350	Axial MTSK-50 Driven Tool	10
TKW0140425	Axial VDI40 ERA25 Cool Thru*	22	TKW0420450	Axial MTSK-50 Driven Tool Cool Thru*	10
TKW0140516	Axial VDI40 Mill Head 16X17	22	TKW0430325	Radial Geared-Up 1:2 Redirected ERA25	7
TKW0140522	Axial VDI40 Mill Head 22X19	22	TKW0430425	Radial Geared-Up 1:2 Redirected ERA25 Cool Thru*	7
TKW0140527	Axial VDI40 Mill Head 27X21	22	TKW0430525	Radial Geared-Up 1:2 Redirected ERA25 for Subspindle	8
TKW0141125	Axial VDI40 Sub-Spindle ER25	25	TKW0430625	Radial Geared-Up 1:2 Redirected ERA25 for Subspindle Cool Thru*	8
TKW0141132	Axial VDI40 Sub-Spindle ER32	25	TKW0440325	Axial Geared-Up 1:2 ERA25	12
TKW0141140	Axial VDI40 Sub-Spindle ER40	25	TKW0440425	Axial Geared-Up 1:2 ERA25 Cool Thru*	12
TKW0141225	Axial VDI40 Sub-Spindle ER25	25	TKW0440525	Axial Geared-Up 1:2 ERA25	12
TKW0141232	Axial VDI40 Sub-Spindle ER32	25	TKW0440625	Axial Geared-Up 1:2 ERA25 Cool Thru*	12
TKW0141240	Axial VDI40 Sub-Spindle ER40	25	TKW0451100	Reinforced Driven Gear Hobb 1:1	32
TKW0141325	Axial VDI40 Sub-Spindle ERA25	25	TKW0452100	Reinforced Driven Gear Hobb Geared-Down 2:1	32
TKW0141425	Axial VDI40 Sub-Spindle ERA25	25	TKW0460150	Radial MTSK-50 Driven Tool	35
TKW0141516	Axial VDI40 Sub-Spindle 16x17	25	TKW0460250	Radial MTSK-50 Driven Tool Cool Thru*	35
TKW0141522	Axial VDI40 Sub-Spindle 22x19	25	TKW0470150	Axial MTSK-50 Driven Tool	37
TKW0141527	Axial VDI40 Sub-Spindle 27x21	25	TKW0470250	Axial MTSK-50 Driven Tool Cool Thru*	37
TKW0151100	Driven Gear Hobber VDI40 1:1	28	TKW0500120	(0-180) Adj. Angle ERA20	3
TKW0151110	Driven Gear Hobber VDI40 1:1	28	TKW0500220	(0-180) Adj. Angle ERA20 Cool Thru*	3
TKW0152100	Driven Gear Hobber VDI40 Geared-Down 2:1	28	TKW0500316	(0-180) Adj. Angle Geared-Up 1:2 ERA16	4
TKW0152110	Driven Gear Hobber VDI40 Geared-Down 2:1	28	TKW0500416	(0-180) Adj. Angle Geared-Up 1:2 ERA16 Cool Thru*	4
TKW0160140	Axial Driven Tool ER40	31	TKW0505120	(0-180) Adj. Angle ERA20 with Digital Display	3
TKW0160240	Axial Driven Tool ER40 Cool Thru*	31	TKW0505220	(0-180) Adj. Angle ERA20 with Digital Display Cool Thru*	3
TKW0160532	Axial Driven Tool Weldon 32	31	TKW0505316	(0-180) Adj. Angle Geared-Up 1:2 ERA16 with Digital Display	4
TKW0160632	Axial Driven Tool Weldon 32 Cool Thru*	31	TKW0505416	(0-180) Adj. Angle Geared-Up 1:2 ERA16 with Digital Display Cool Thru*	4
TKW0170140	Radial Driven Tool ER40	29	TKW0510140	Axial VDI40 MTSK-40 Driven Tool	21
TKW0180132	Axial Driven Tool ER32	34	TKW0510240	Axial VDI40 MTSK-40 Driven Tool Cool Thru*	21
TKW0180140	Axial Driven Tool ER40	34	TKW0511140	Axial VDI40 MTSK-40 Driven Tool	24
TKW0180232	Axial Driven Tool ER32 Cool Thru*	34	TKW0511240	Axial VDI40 MTSK-40 Driven Tool Cool Thru*	24
TKW0180240	Axial Driven Tool ER40 Cool Thru*	34	TKW0520140	Axial VDI40 MTSK-40 Driven Tool	23
TKW0190132	Radial Driven Tool ER32	33	TKW0520240	Axial VDI40 MTSK-40 Driven Tool Cool Thru*	23
TKW0200132	Axial Opposite Face Driven ER32+ER32	34	TKW0521140	Axial VDI40 MTSK-40 Driven Tool	26
TKW0210125	Radial Single Side Twin ER25	33	TKW0521240	Axial VDI40 MTSK-40 Driven Tool Cool Thru*	26
TKW0210225	Radial Single Side Twin ER25 Cool Thru*	33	TKW0530225	Axial Single Side Twin ER25	38
TKW0222125	Radial Geared-up 1:2 Re-directed ERA25	1	TKW0540225	Radial Single Side Twin ER25	36
TKW0222225	Radial Geared-up 1:2 Re-directed ERA25 Cool Thru*	1	TKW0552500	Radial Single Side Twin Static Tool 25mm	43
TKW0260016	Axial Geared-Up 1:3 Driven Tool VDI40	27	TKW0562500	Axial Double Boring Bar Holder 25mm	46
TKW0261016	Axial Geared-Up 1:3 Driven Tool VDI40	27	TKW0570332	Radial Redirected in Z by 80mm ERA32	89
TKW0300132	Radial Driven Tool ER32	35	TKW0570432	Radial Redirected in Z by 80mm ERA32 Cool Thru*	89
TKW0300240	Radial Driven Tool ER40 Cool Thru*	35	TKW0571332	Radial Geared-Down 2:1 Redirected ERA32	89
TKW0310132	Axial Driven Tool ER32	37	TKW0571432	Radial Geared-Down 2:1 Redirected ERA32 Cool Thru*	89
TKW0310140	Axial Driven Tool ER40	37	TKW0582500	Radial Rear-Set Single Static Tool 25mm	42
TKW0310232	Axial Driven Tool ER32 Cool Thru*	37	TKW0590100	Broaching/Slotting Driven Tool 50mm Stroke	16
TKW0310240	Axial Driven Tool ER40 Cool Thru*	37	TKW0590200	Broaching/Slotting Driven Tool 25mm Stroke	16
TKW0320132	Axial Opposite Face Driven Tool ER32+ER32	38	TKW0610120	Radial Geared-Up 1:4 Redirected ER20	90
TKW0330120	(0-180) Adj. Angle ERA20	39	TKW0660140	Radial Driven Tool ER40 Cool Thru*	29
TKW0330220	(0-180) Adj. Angle ERA20 Cool Thru*	39	TKW0670132	Axial Driven Tool ER32	91
TKW0330316	(0-180) Adj. Angle Geared-Up 1:2 ERA16	40	TKW0670232	Axial Driven Tool ER32 Cool Thru*	91
TKW0330416	(0-180) Adj. Angle Geared-Up 1:2 ERA16 Cool Thru*	40	TKW0682500	Radial Single Static Tool 25mm	92
TKW0335120	(0-180) Adj. Angle ERA20 with Digital Display	39	TKW0692500	Axial Single Static Tool 25mm	92
TKW0335220	(0-180) Adj. Angle ERA20 with Digital Display Cool Thru*	39	TKW0704000	Axial Single Boring Bar Holder 40mm	93
TKW0335316	(0-180) Adj. Angle ERA16 Geared-Up 1:2 with Digital Display	40	TKW0710120	(0-180) Adj. Angle ER20	15
TKW0335416	(0-180) Adj. Angle ERA16 Geared-Up 1:2 with Digital Display Cool Thru*	40	TKW0710125	(0-180) Adj. Angle ER25	15
TKW0342500	Radial Single Static Tool 25mm	42	TKW0710516	(0-180) Adj. Angle Ø16x17	15
TKW0352500	Radial Double Static Tool 25mm	43	TKW0710519	(0-180) Adj. Angle 3/4"x3/4"	15
TKW0360132	Radial Blade Holder with Blade Kit	44	TKW0710522	(0-180) Adj. Angle Ø22x19	15
TKW0370132L	Radial Blade Holder with Cool Thru Left Hand	44	TKW0720120	(0-180) Adj. Angle ER20 with Digital Display	15
TKW0370132R	Radial Blade Holder with Cool Thru Right Hand	44	TKW0720125	(0-180) Adj. Angle ER25 with Digital Display	15
TKW0382500	Axial Single Static Tool 25mm	45	TKW0720516	(0-180) Adj. Angle Ø16x17 with Digital Display	15
TKW0394000	Axial Single Boring Bar Holder 40mm	45			
TKW0414000	Axial Opposite Face Boring Bar Holder 40mm	46			

Table of Contents

Part Number Index

TKW0720519	(0-180) Adj. Angle 3/4"x3/4" with Digital Display	15
TKW0720522	(0-180) Adj. Angle Ø22x19 with Digital Display	15
TKW0730325	Radial Single Side Twin ERA25	8
TKW0740125	Axial Rear-Set ER25	11
TKW0740225	Axial Rear-Set ER25 Cool Thru*	11
TKW0741125	Axial Rear-Set ER25	11
TKW0741225	Axial Rear-Set ER25 Cool Thru*	11
TKW0750325	Axial Single Side Twin ERA25	14
TKW0751325	Axial Single Side Twin ERA25	14
TKW0760120	(0-180) Adj. Angle ER20	31
TKW0760125	(0-180) Adj. Angle ER25	31
TKW0760516	(0-180) Adj. Angle 16x17	31
TKW0760519	(0-180) Adj. Angle 3/4"x3/4"	31
TKW0760522	(0-180) Adj. Angle 22x19	31
TKW0784000	Axial Rear-Set Boring Bar Holder 40mm	93
TKW0790325	Radial Inverted Driven Tool Redirected ERA25	30
TKW0800132	Radial Driven Tool ER32 Cool Thru*	35
TKW0844010	Radial Single Static Tool Capto C4 Right Version	19
TKW0844010LC	Radial Single Static Tool Capto C4 Left Version	19
TKW0854010	Axial Single Static Tool Capto C4 Right Version	19
TKW0854010LC	Axial Single Static Tool Capto C4 Left Version	19
TKW0861100	Driven Gear Hobb 1:1	41
TKW0862100	Driven Gear Hobb Geared-Down 2:1	41
TKW0872000	Axial Double BBH 20mm	18
TKW0872500	Axial Double BBH 25mm	18
TKW0873200	Axial Double BBH 32mm	18
TKW0882500	Radial Single Static Tool 25mm	17
TKW0892500	Axial Single Static Tool 25mm	18
TKW0902500	Radial Single Side Twin Static Tool 25mm	17
TPGN220408	10 Inserts for Polygon Making Mill Heads	98
TPGN220408	10 Inserts for Polygon Making Mill Heads	98