

Top[®]

AUTOMAZIONI

BAR FEEDERS & AUTOMATIONS



**NO MORE REASONS
TO WAIT**



**SUITABLE FOR FIXED-HEAD CNC LATHES
WITH SPINDLE CAPACITY
FROM 6 mm (0.23") TO 50 mm (1.96")***

**QUICK INTERCHANGEABLE GUIDE
CHANNEL**

**AVAILABLE IN 3200 mm (10.5') AND
4100 mm (13') LENGTH CAPACITIES**



*The minimum and maximum values are set according to the lathe model.

BAR FEEDER LAYOUT

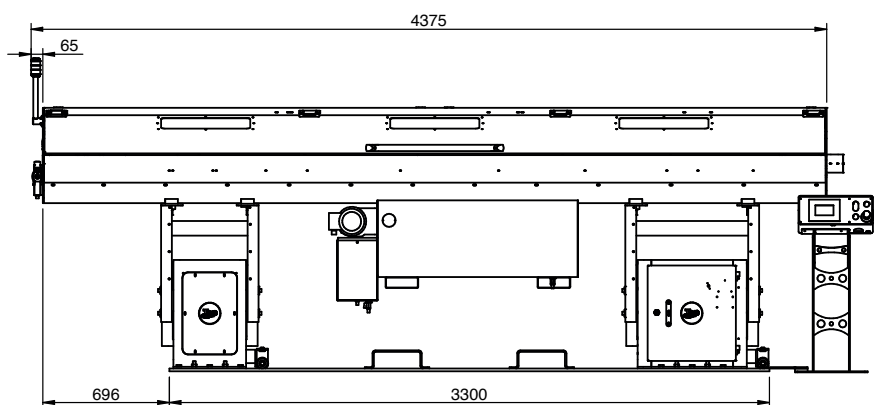
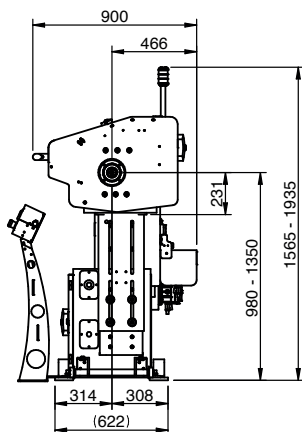



Scan the QR CODE to watch the video

Top[®]
AUTOMAZIONI



BETA

TECHNICAL DATA	
	BETA
∅ ROUND BARS	6 mm - 50 mm / 0.23" - 1.96"
∅ HEXAGONAL BARS	6 mm - 45 mm / 0.23" - 1.77"
∅ SQUARE BARS	6 mm - 37 mm / 0.23" - 1.45"
↕ BAR LENGTH	1200 mm - 3200 mm / 47.24" - 125.98" 1200 mm - 4100 mm / 47.24" - 161.41"
⌚ MAX FEED SPEED	30 m/min - 98.42'/min
↕ MAX REMNANT LENGTH	300 mm / 11.81"
🌀 AIR PRESSURE REQUIRED	6.5 - 7.5 bar



GUIDE CHANNEL

BETA features a round section guide channel, manually interchangeable; entirely made of plastic material, Vulkollan type, the guide channel is extremely resistant and suitable for high speed bar processing.



FRONT STEADY BLOCK

BETA features a special steady block, in the front part of the bar feeder, interchangeable every 5 mm (0.19"), in order to reach the highest performances in the bar rotation.

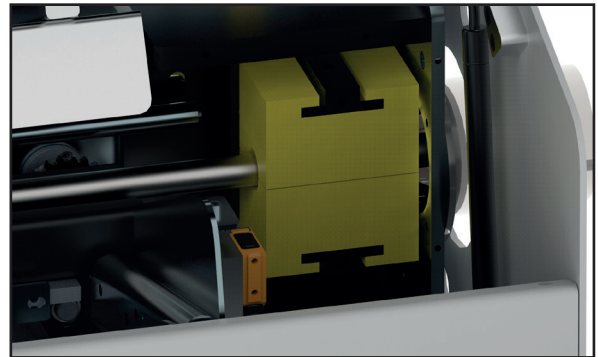

REMNANT EXTRACTION

BETA offers two different remnant managements:

- 1) Rear extraction performed by means of a self centering extractor
- 2) Front ejection

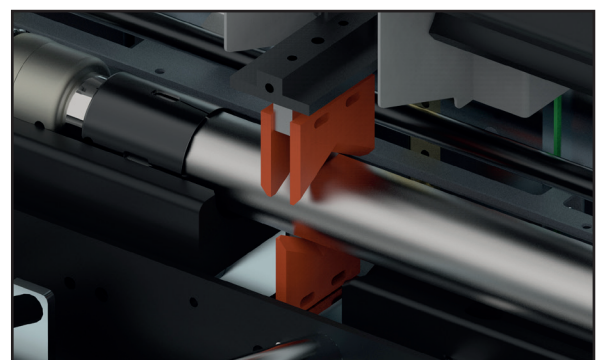

REPOSITIONING SYSTEM

BETA doesn't require the spindle liner, but it can be equipped with a rail system that enables axial 600 mm (23.62") or radial 600 mm (23.62") displacement (alternative option), helping the lathe servicing.



AUTOMATIC MANAGEMENT

The BETA bar feeder is completely managed by a PLC interacting with a brushless motor and a digital pneumatic valves system which controls speed, thrust and all the automations.



BETA

BAR STORAGE

BETA can be equipped with one single level magazine, featuring a single storage with 235 mm (9.25") carrying capacity.



SINGLE LEVEL



HOW TO FIND US ►
scan QR code



TOP AUTOMAZIONI S.R.L.

Via Torrianese, 62
47824 Poggio Torriana (RN)

Tel. +39 0541 688248

Fax +39 0541 688168

topautomazioni@topautomazioni.com

www.topautomazioni.com

